

Cartesian Type 6-Axis Robot **CRS**

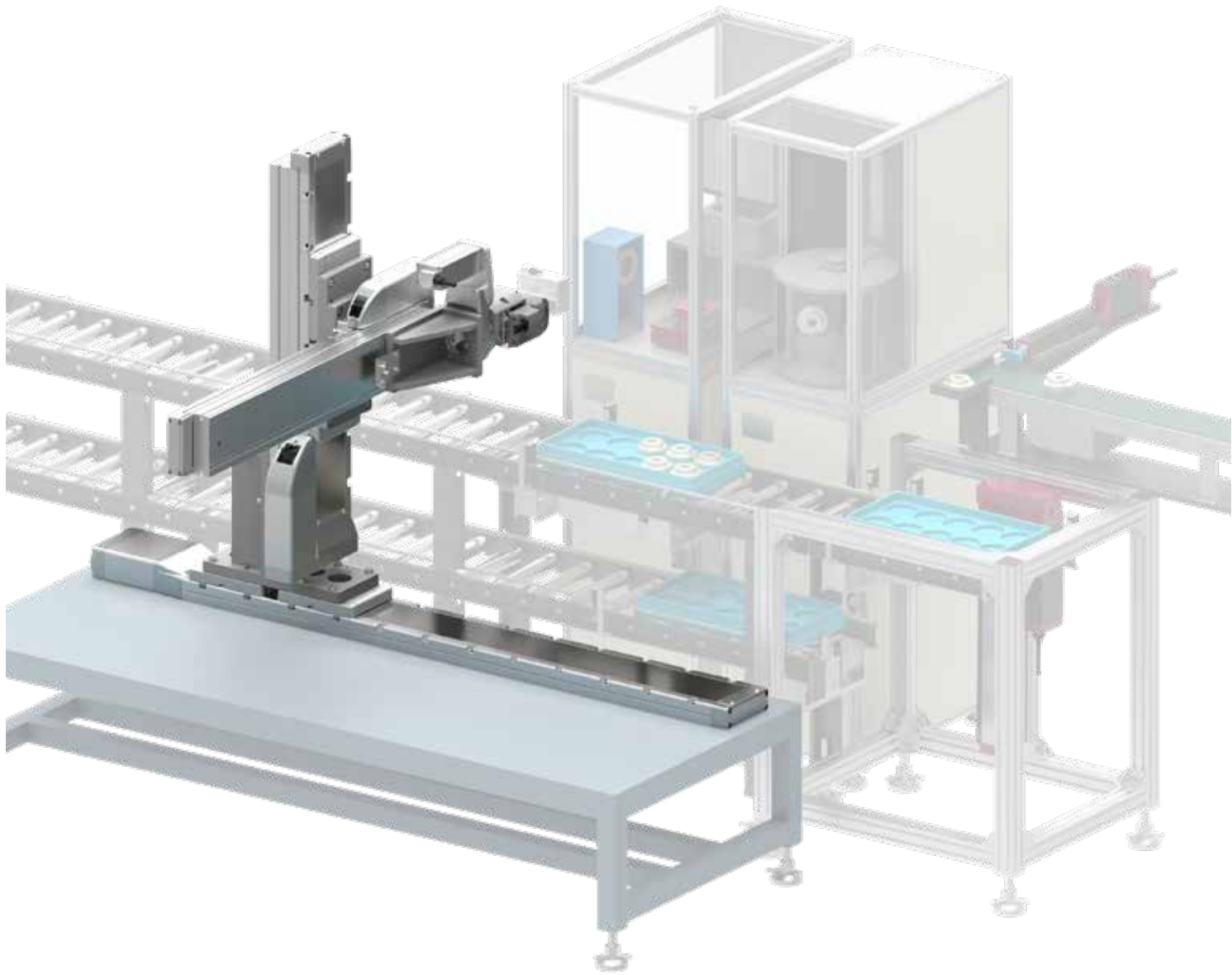

Robot with 6 degrees of freedom combining 3 cartesian and 3 rotational axes.

Operations with a high degree of freedom are possible including rotation and turning.

1

Many variations and combinations are available.

Ten different combinations are available.

An optimal combination can be selected according to payload, traveling stroke and installation space.

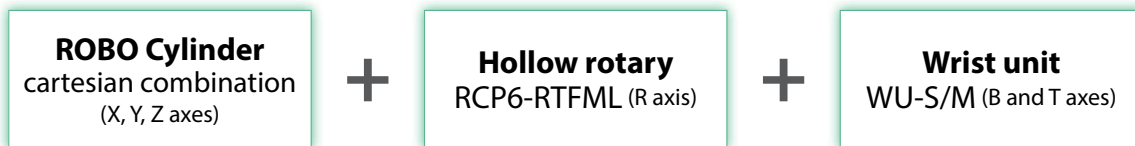

Sway and rotational movements to the horizontal surface (XY plane) is possible.

Details on P5.

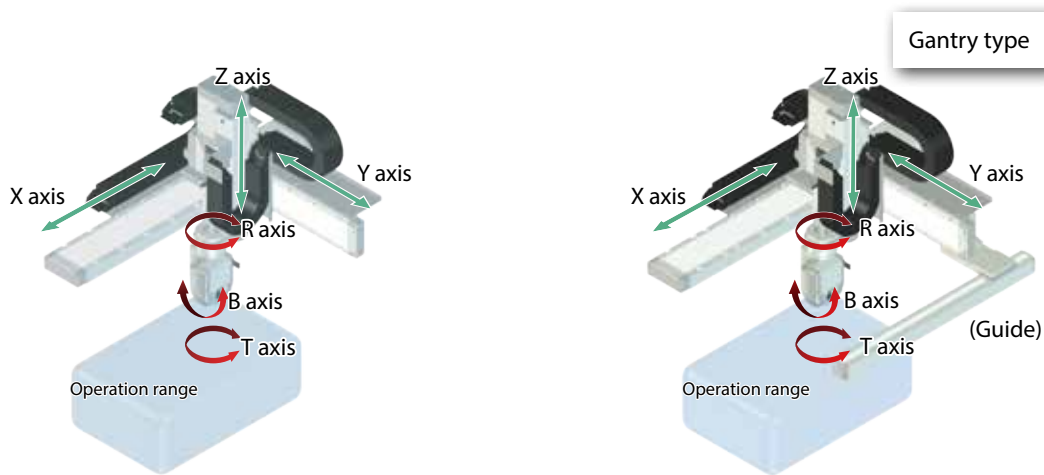

Sway and rotational movements to the wall surface (YZ plane) is possible.

Details on P6.

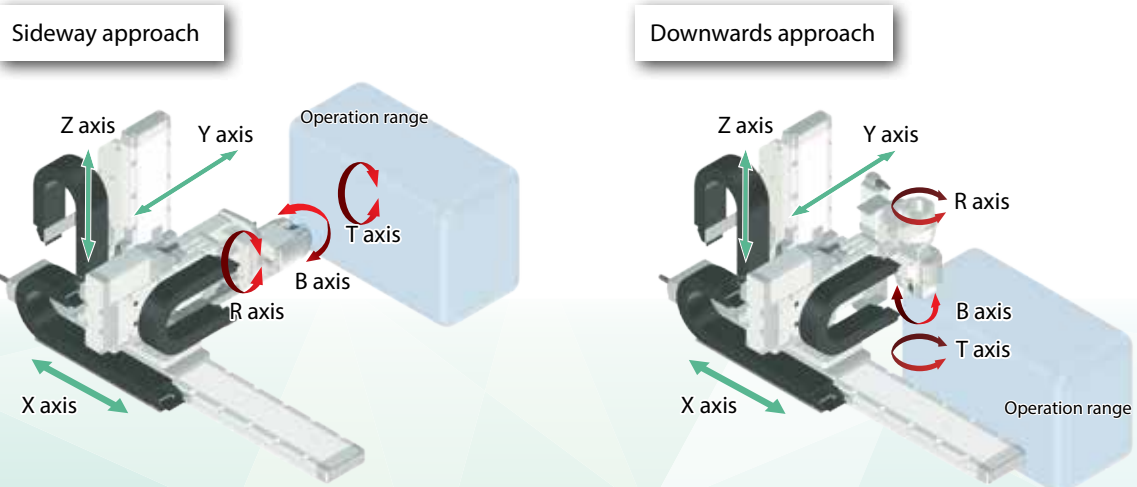

2

Strokes can be selected for each of X, Y and Z axes

An optimal size can be selected by setting the strokes of each axis.
Minimal cost increase by stroke length.

(Ex.) Changing the stroke of the X-axis of CRS-XBA from 200mm to 800mm.

Strokes XYZ : **200mm** × 300mm × 190mm

Strokes XYZ : **800mm** × 300mm × 190mm

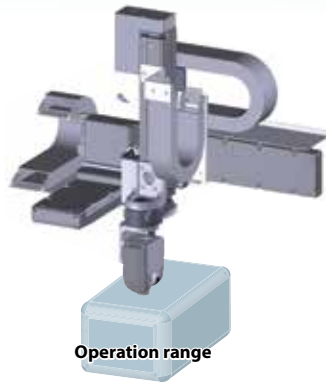
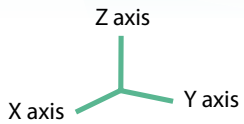

(Cartesian actuators only)

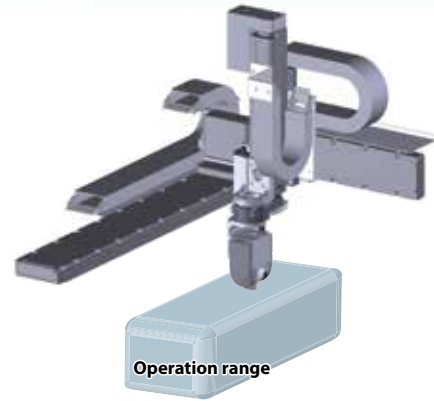
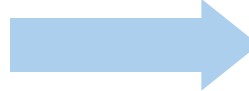

(Cartesian actuators only)

3

Battery-less absolute encoders are equipped standard.

Application

Loading and unloading gears for cleaning and external inspection.

Equipment to wash machined gears and perform an external inspection.
A Cartesian Type 6-Axis Robot (CRS-XZDY) performs machine tending for washing equipment and inspection for external appearance from three directions.

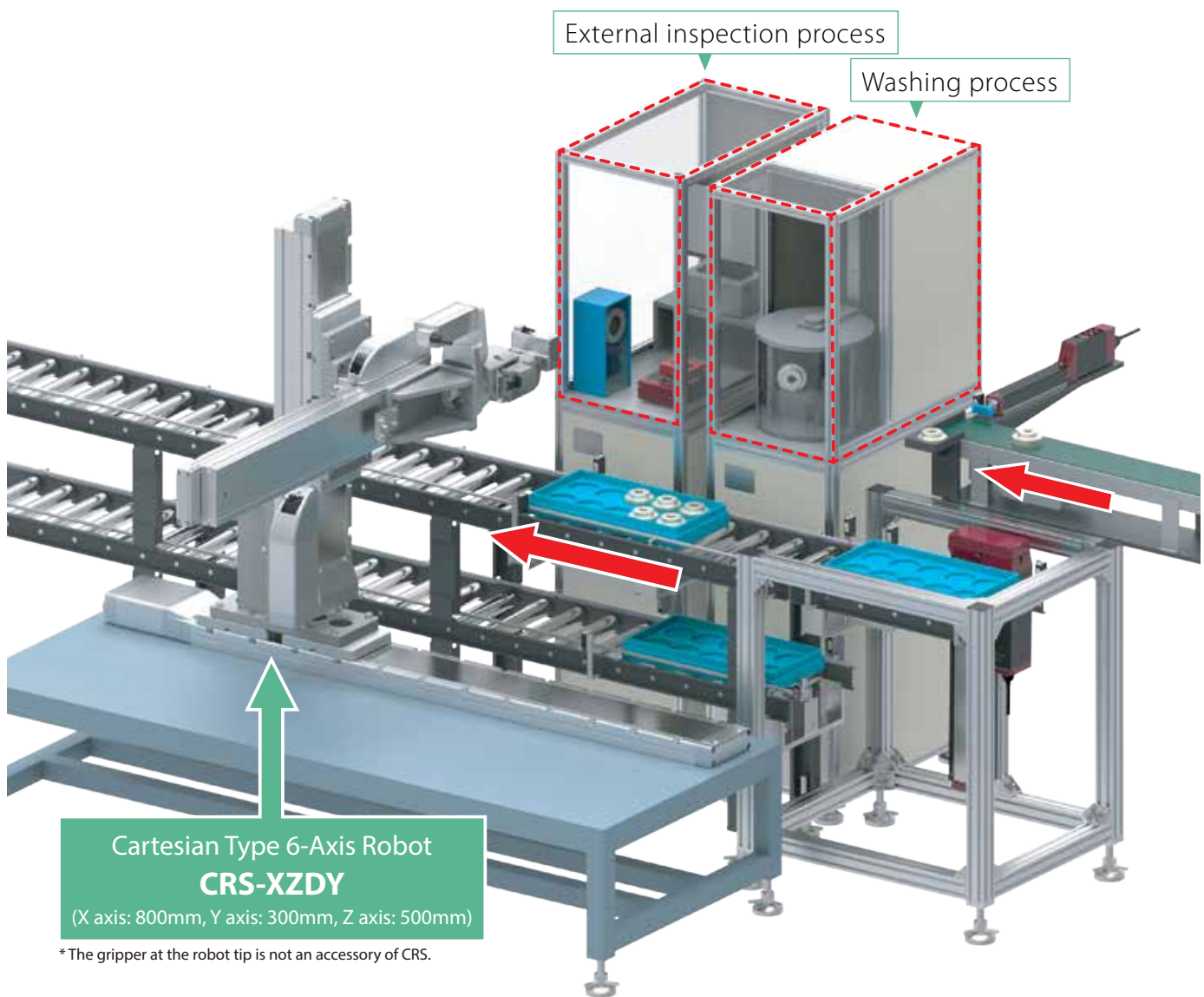

Loading and unloading gears from the washing station.

Picks up the gear from the previous process and places it in the washing equipment.
After washing, the gear is taken out and transferred to the external appearance inspection process.

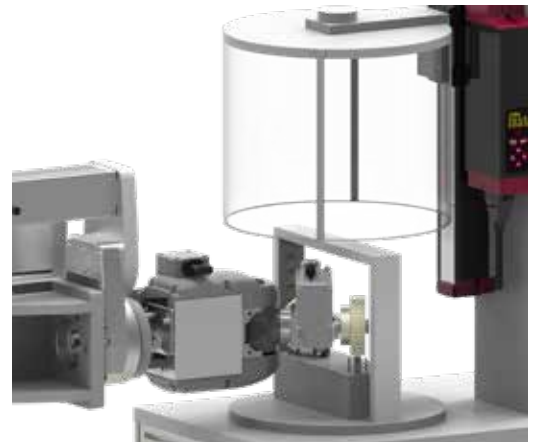

External inspection

As shown in the illustration, the gear is inspected from 3 angles, by changing its direction in front of an inspection camera.

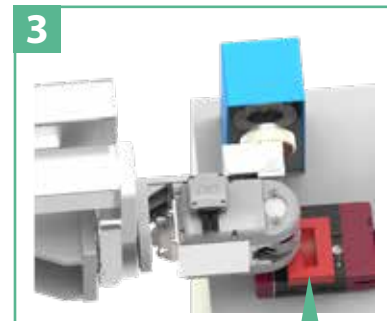
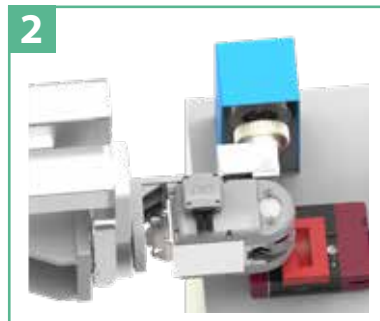
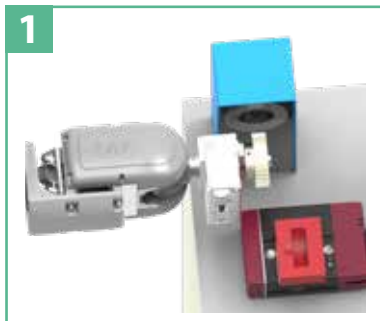
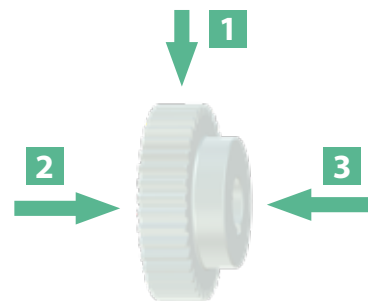

The gear is turned over by rotary type (EC-TRC).

Filling the pallet

After inspection, good gears are placed in the pallet.



Full Line Up

Three-dimensional movements are possible within a work envelope.



Recommended for pick & place, assembling and inspection.

- XYB (Y-axis base mounted) + Z-axis base mounted type
- XYG (gantry Y-axis horizontal) + Z-axis base mounted type

Y-axis long stroke



Gantry combination

<p>Long stroke X-axis, high speed, high payload</p>	<p>Model: CRS-XBA</p> <table border="1"> <tr> <td>Max. operation range</td> <td>X-axis 800mm</td> <td>Y-axis 300mm</td> <td>Z-axis 190mm</td> </tr> <tr> <td>Maximum payload</td> <td colspan="3">1 kg</td> </tr> <tr> <td>Standard cycle time</td> <td colspan="3">2.07 seconds</td> </tr> <tr> <td>Positioning repeatability</td> <td colspan="3">± 0.03 mm</td> </tr> </table> <p style="text-align: right;">P.15</p>	Max. operation range	X-axis 800mm	Y-axis 300mm	Z-axis 190mm	Maximum payload	1 kg			Standard cycle time	2.07 seconds			Positioning repeatability	± 0.03 mm			<p>Model: CRS-XGA</p> <table border="1"> <tr> <td>Max. operation range</td> <td>X-axis 800mm</td> <td>Y-axis 600mm</td> <td>Z-axis 190mm</td> </tr> <tr> <td>Maximum payload</td> <td colspan="3">1 kg</td> </tr> <tr> <td>Standard cycle time</td> <td colspan="3">2.11 seconds</td> </tr> <tr> <td>Positioning repeatability</td> <td colspan="3">± 0.03 mm</td> </tr> </table> <p style="text-align: right;">P.23</p>	Max. operation range	X-axis 800mm	Y-axis 600mm	Z-axis 190mm	Maximum payload	1 kg			Standard cycle time	2.11 seconds			Positioning repeatability	± 0.03 mm		
	Max. operation range	X-axis 800mm	Y-axis 300mm	Z-axis 190mm																														
	Maximum payload	1 kg																																
	Standard cycle time	2.07 seconds																																
Positioning repeatability	± 0.03 mm																																	
Max. operation range	X-axis 800mm	Y-axis 600mm	Z-axis 190mm																															
Maximum payload	1 kg																																	
Standard cycle time	2.11 seconds																																	
Positioning repeatability	± 0.03 mm																																	
<p>Model: CRS-XBB</p> <table border="1"> <tr> <td>Max. operation range</td> <td>X-axis 1100mm</td> <td>Y-axis 300mm</td> <td>Z-axis 200mm</td> </tr> <tr> <td>Maximum payload</td> <td colspan="3">2 kg</td> </tr> <tr> <td>Standard cycle time</td> <td colspan="3">1.66 seconds</td> </tr> <tr> <td>Positioning repeatability</td> <td colspan="3">± 0.03 mm</td> </tr> </table> <p style="text-align: right;">P.19</p>	Max. operation range	X-axis 1100mm	Y-axis 300mm	Z-axis 200mm	Maximum payload	2 kg			Standard cycle time	1.66 seconds			Positioning repeatability	± 0.03 mm			<p>Model: CRS-XGB</p> <table border="1"> <tr> <td>Max. operation range</td> <td>X-axis 1100mm</td> <td>Y-axis 600mm</td> <td>Z-axis 200mm</td> </tr> <tr> <td>Maximum payload</td> <td colspan="3">2 kg</td> </tr> <tr> <td>Standard cycle time</td> <td colspan="3">1.66 seconds</td> </tr> <tr> <td>Positioning repeatability</td> <td colspan="3">± 0.04 mm</td> </tr> </table> <p style="text-align: right;">P.27</p>	Max. operation range	X-axis 1100mm	Y-axis 600mm	Z-axis 200mm	Maximum payload	2 kg			Standard cycle time	1.66 seconds			Positioning repeatability	± 0.04 mm			
Max. operation range	X-axis 1100mm	Y-axis 300mm	Z-axis 200mm																															
Maximum payload	2 kg																																	
Standard cycle time	1.66 seconds																																	
Positioning repeatability	± 0.03 mm																																	
Max. operation range	X-axis 1100mm	Y-axis 600mm	Z-axis 200mm																															
Maximum payload	2 kg																																	
Standard cycle time	1.66 seconds																																	
Positioning repeatability	± 0.04 mm																																	

* Standard cycle time

The standard cycle time is based on a reciprocating operation at the highest speed on the following condition. The cycle time can be higher than the specified value depending on stroke and operating conditions.

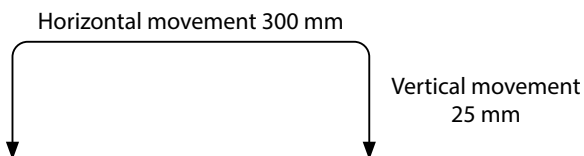

* Maximum payload

The maximum payload may decrease depending on the workpiece and its center of gravity.

Accessing difficult to reach locations is possible.



Recommended for loading and unloading machines

- XZ (Z-axis vertical) + Y-axis radial cylinder type
- XZ (Z-axis vertical) + Y-axis slider type

	Side approach	Downward approach																																
<p>Long stroke Y-axis</p>	<p>Model: CRS-XZCY</p> <table border="1"> <tr> <td>Max. operation range</td> <td>X-axis 800mm</td> <td>Z-axis 300mm</td> <td>Y-axis 200mm</td> </tr> <tr> <td>Maximum payload</td> <td colspan="3">1 kg</td> </tr> <tr> <td>Standard cycle time</td> <td colspan="3">2.55 seconds</td> </tr> <tr> <td>Positioning repeatability</td> <td colspan="3">± 0.06 mm</td> </tr> </table> <p>P.31</p>	Max. operation range	X-axis 800mm	Z-axis 300mm	Y-axis 200mm	Maximum payload	1 kg			Standard cycle time	2.55 seconds			Positioning repeatability	± 0.06 mm			<p>Model: CRS-XZCZ</p> <table border="1"> <tr> <td>Max. operation range</td> <td>X-axis 800mm</td> <td>Z-axis 300mm</td> <td>Y-axis 200mm</td> </tr> <tr> <td>Maximum payload</td> <td colspan="3">1 kg</td> </tr> <tr> <td>Standard cycle time</td> <td colspan="3">2.55 seconds</td> </tr> <tr> <td>Positioning repeatability</td> <td colspan="3">± 0.06 mm</td> </tr> </table> <p>P.35</p>	Max. operation range	X-axis 800mm	Z-axis 300mm	Y-axis 200mm	Maximum payload	1 kg			Standard cycle time	2.55 seconds			Positioning repeatability	± 0.06 mm		
	Max. operation range	X-axis 800mm	Z-axis 300mm	Y-axis 200mm																														
Maximum payload	1 kg																																	
Standard cycle time	2.55 seconds																																	
Positioning repeatability	± 0.06 mm																																	
Max. operation range	X-axis 800mm	Z-axis 300mm	Y-axis 200mm																															
Maximum payload	1 kg																																	
Standard cycle time	2.55 seconds																																	
Positioning repeatability	± 0.06 mm																																	
<p>High speed</p>	<p>Model: CRS-XZDY</p> <table border="1"> <tr> <td>Max. operation range</td> <td>X-axis 800mm</td> <td>Z-axis 300mm</td> <td>Y-axis 500mm</td> </tr> <tr> <td>Maximum payload</td> <td colspan="3">1 kg</td> </tr> <tr> <td>Standard cycle time</td> <td colspan="3">2.28 seconds</td> </tr> <tr> <td>Positioning repeatability</td> <td colspan="3">± 0.03mm</td> </tr> </table> <p>P.39</p>	Max. operation range	X-axis 800mm	Z-axis 300mm	Y-axis 500mm	Maximum payload	1 kg			Standard cycle time	2.28 seconds			Positioning repeatability	± 0.03mm			<p>Model: CRS-XZDZ</p> <table border="1"> <tr> <td>Max. operation range</td> <td>X-axis 800mm</td> <td>Z-axis 300mm</td> <td>Y-axis 500mm</td> </tr> <tr> <td>Maximum payload</td> <td colspan="3">1 kg</td> </tr> <tr> <td>Standard cycle time</td> <td colspan="3">2.28 seconds</td> </tr> <tr> <td>Positioning repeatability</td> <td colspan="3">± 0.03mm</td> </tr> </table> <p>P.43</p>	Max. operation range	X-axis 800mm	Z-axis 300mm	Y-axis 500mm	Maximum payload	1 kg			Standard cycle time	2.28 seconds			Positioning repeatability	± 0.03mm		
Max. operation range	X-axis 800mm	Z-axis 300mm	Y-axis 500mm																															
Maximum payload	1 kg																																	
Standard cycle time	2.28 seconds																																	
Positioning repeatability	± 0.03mm																																	
Max. operation range	X-axis 800mm	Z-axis 300mm	Y-axis 500mm																															
Maximum payload	1 kg																																	
Standard cycle time	2.28 seconds																																	
Positioning repeatability	± 0.03mm																																	
	<p>Model: CRS-XZEY</p> <table border="1"> <tr> <td>Max. operation range</td> <td>X-axis 800mm</td> <td>Z-axis 300mm</td> <td>Y-axis 500mm</td> </tr> <tr> <td>Maximum payload</td> <td colspan="3">1 kg</td> </tr> <tr> <td>Standard cycle time</td> <td colspan="3">1.69 seconds</td> </tr> <tr> <td>Positioning repeatability</td> <td colspan="3">± 0.03mm</td> </tr> </table> <p>P.47</p>	Max. operation range	X-axis 800mm	Z-axis 300mm	Y-axis 500mm	Maximum payload	1 kg			Standard cycle time	1.69 seconds			Positioning repeatability	± 0.03mm			<p>Model: CRS-XZ EZ</p> <table border="1"> <tr> <td>Max. operation range</td> <td>X-axis 800mm</td> <td>Z-axis 300mm</td> <td>Y-axis 500mm</td> </tr> <tr> <td>Maximum payload</td> <td colspan="3">1 kg</td> </tr> <tr> <td>Standard cycle time</td> <td colspan="3">1.69 seconds</td> </tr> <tr> <td>Positioning repeatability</td> <td colspan="3">± 0.03mm</td> </tr> </table> <p>P.51</p>	Max. operation range	X-axis 800mm	Z-axis 300mm	Y-axis 500mm	Maximum payload	1 kg			Standard cycle time	1.69 seconds			Positioning repeatability	± 0.03mm		
Max. operation range	X-axis 800mm	Z-axis 300mm	Y-axis 500mm																															
Maximum payload	1 kg																																	
Standard cycle time	1.69 seconds																																	
Positioning repeatability	± 0.03mm																																	
Max. operation range	X-axis 800mm	Z-axis 300mm	Y-axis 500mm																															
Maximum payload	1 kg																																	
Standard cycle time	1.69 seconds																																	
Positioning repeatability	± 0.03mm																																	

Model Specification Items

For combination types, refer to the Full Line Up on P5 - P6.
Confirm the cable track size on each product pages.

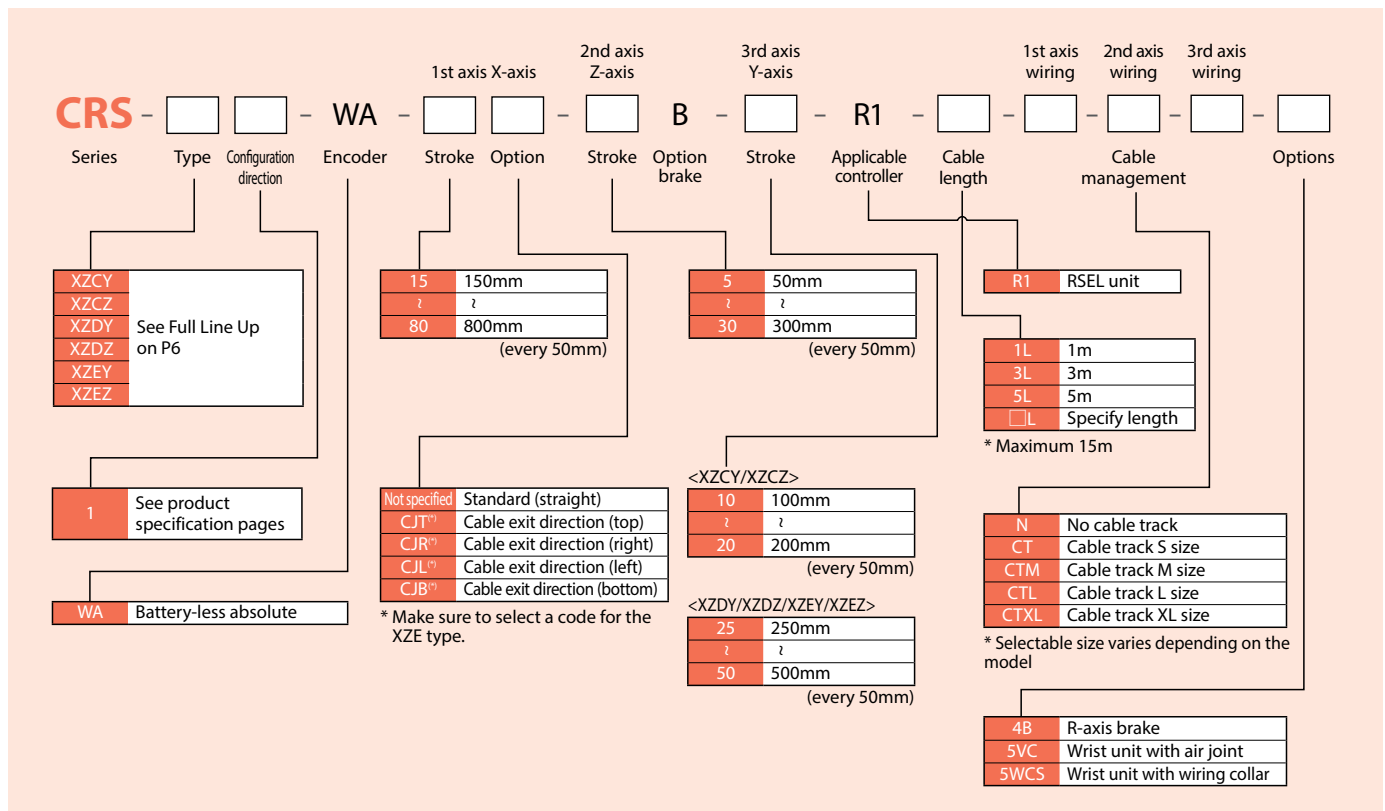
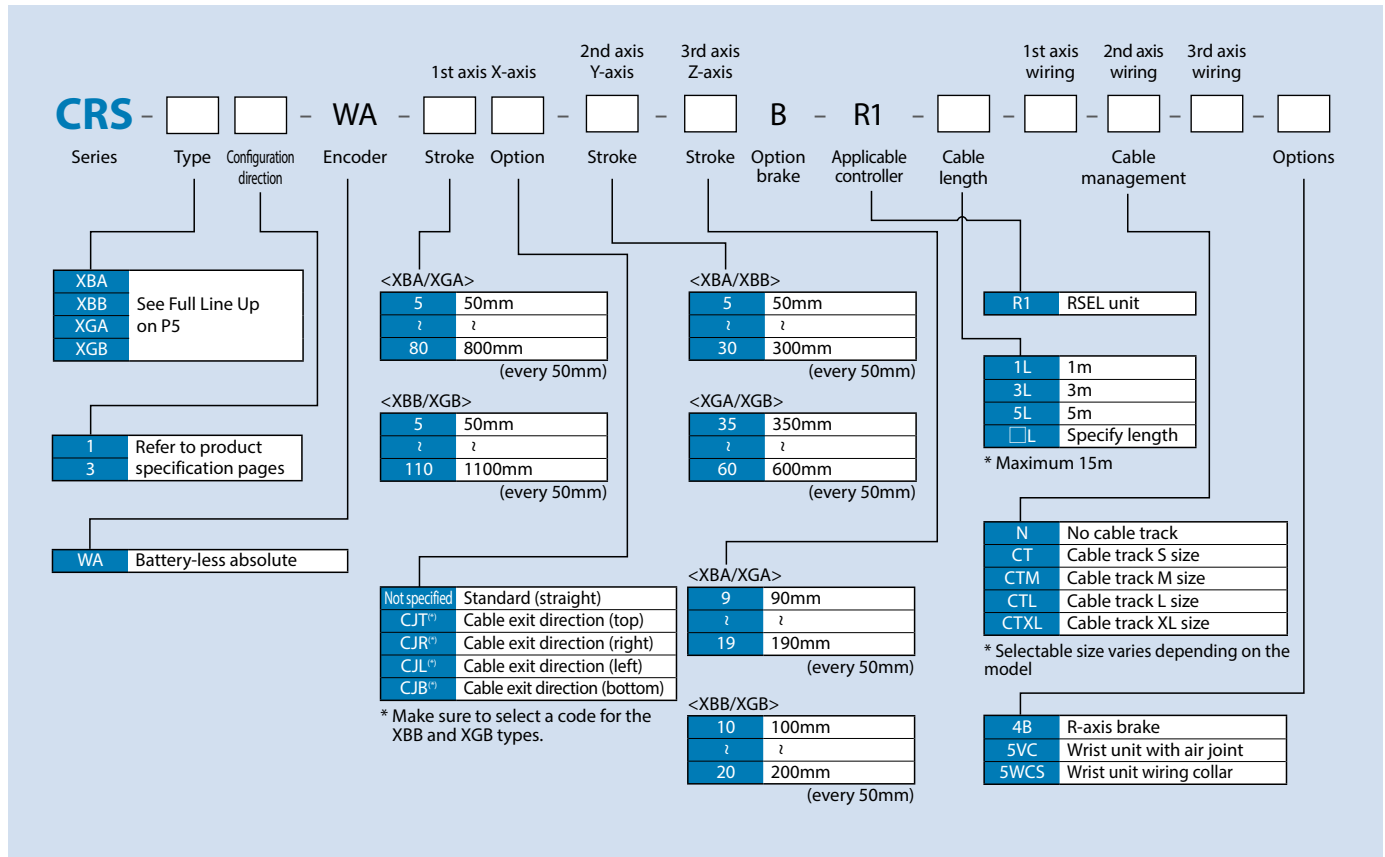

Options

X-axis cable exit direction change

Model CJT / CJR / CJL / CJB

Description The mounting direction of the motor encoder cables on the actuator are changeable: top and bottom or left and right. Confirm the directions in the dimensional drawing on the individual axis specs sheets.

R-axis brake

Model 4B

Description It prevents the rotary axis from moving at the time of power failure or servo OFF. When using the rotary axis horizontally, it prevents the workpiece from dropping off due to the rotation of the axis. (Brakes are standard equipment on the Z-axis and the BT axes for the wrist unit.)

Wrist unit with air joint

Model 5VC

Description This is an option to attach an air joint ($\Phi 6\text{mm}$) on the side of the actuator when mounting a pneumatic device, such as a vacuum pad, to the wrist unit. It is mounted on the same surface as the wrist unit's pigtail cable.

Wrist unit with wiring collar

Model 5WCS

Description The wrist unit wiring collar makes wiring easier when using an electric gripper. The wiring collar is used as the base to which a wiring bracket (supplied by the customer) is mounted.

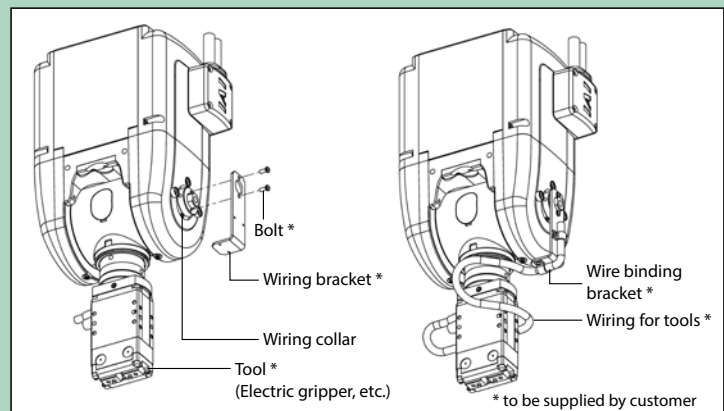

Technical reference

Model selection procedure

Follow steps 1-4 for selection.

Step 1

Confirm the mass of workpiece.

Calculate the mass of workpiece to be attached on the wrist unit and make sure that it is less than the maximum payload.

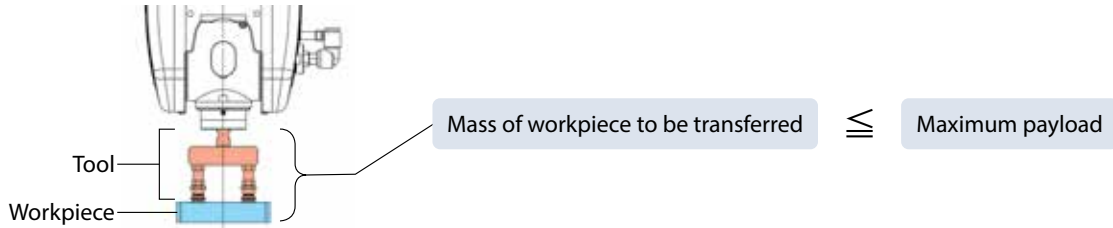

Type	Wrist Unit	Maximum payload
CRS-XBA	WU-S	1kg
CRS-XBB	WU-M	2kg
CRS-XGA	WU-S	1kg
CRS-XGB	WU-M	2kg

Type	Wrist Unit	Maximum payload
CRS-XZCY	WU-S	1kg
CRS-XZCZ		
CRS-XZDY		
CRS-XZDZ		
CRS-XZEY		
CRS-XZEX		

Step 2

Confirm the moment of inertia

When load torque is applied on the B or T axis, the allowable moment of inertia will be decreased accordingly. Calculate load torque first, then determine compensated allowable moment of inertia.

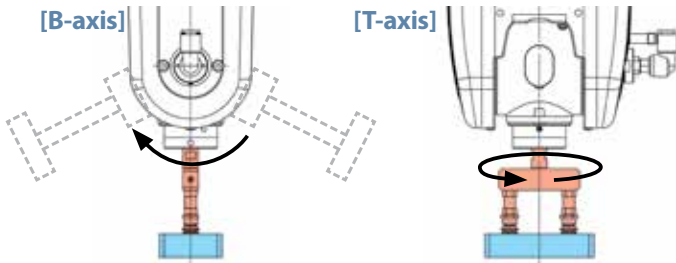

Page 12 shows the "how to calculate the moment of inertia of standard object shapes."

Confirm the existence of "load torque" on B-axis and T-axis.

If there is load torque:

Moment of inertia applied on B-axis and T-axis.



Compensated allowable moment of inertia for both the small and medium wrist types.*

* varies depending on speed and acceleration/deceleration.

If there is no load torque:

Moment of inertia applied on B-axis and T-axis.



Allowable moment of inertia for both the small and medium wrist types.*

* varies depending on speed and acceleration/deceleration.

Condition of load torque

	Existence of load torque				
	①	②	③	④	⑤
Mounting orientation					
B-axis	Yes	Yes	No	Yes	Yes
T-axis	No	Yes	No	No	Yes

If there is load torque:

Moment of inertia applied on B-axis and T-axis.



Compensated allowable moment of inertia for both the small and medium wrist types.*

* varies depending on speed and acceleration/deceleration.

(1) Calculation of load torque T_i

B-axis

$$T_i = T_{IT} + T_{IW}$$

$$= m_T \cdot g(r_o + r_{CT}) \times 10^{-3} + m_W \cdot g(r_o + r_{CW}) \times 10^{-3}$$

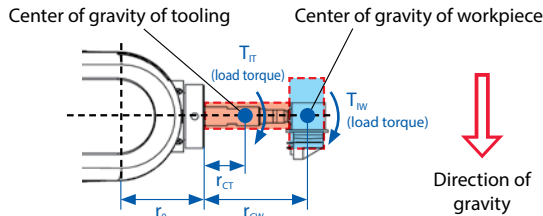

T_{IT} : Load torque caused by tooling [N · m]
 T_{IW} : Load torque caused by the workpiece [N · m]
 m_T : Tooling mass [kg]
 m_W : Workpiece mass [kg]
 g : Gravitational acceleration [m/s²]
 r_o : Distance of mounting surface [mm]
 r_{CT} : Distance to tooling's center of gravity [mm]
 r_{CW} : Distance to workpiece's center of gravity [mm]

T-axis

$$T_i = m \cdot g \cdot r_c \times 10^{-3}$$

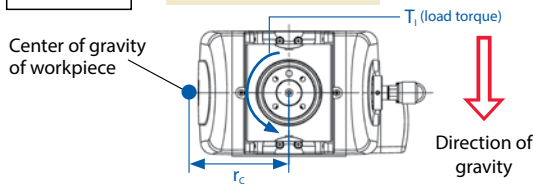

T_i : Load torque caused by the workpiece [N · m]
 m : Workpiece mass (be consistent with above) [kg]
 g : Gravitational acceleration [m/s²]
 r_c : Distance to workpiece's center of gravity [mm]

(2) Calculating the compensation coefficient (C_j) for the allowable moment of inertia

$$C_j = \frac{T_{max} - T_i}{T_{max}}$$

T_{max} : Output torque (from table) [Nm]
 T_i : Calculated result of load torque (1)

Output torque by speed [Nm]

WU-S: Small type

Speed Degree/s	B-axis	T-axis
0	0.65	0.65
150	0.65	0.65
300	0.62	0.62
450	0.6	0.6
600	0.58	0.58
750	0.52	0.52
900	0.45	0.45
1050	0.45	0.45
1200	0.45	0.45

WU-M: Medium type

Speed Degree/s	B-axis	T-axis
0	1.65	1.65
150	1.65	1.65
300	1.65	1.65
450	1.65	1.65
600	1.58	1.58
750	1.36	1.36
900	1.14	1.14
1050	0.96	0.96
1200	0.79	0.79

(3) Calculating the compensated allowable moment of inertia (J_{it})

$$J_{it} = J_{max} C_j \text{ (kgm}^2\text{)}$$

J_{max} : Allowable moment of inertia (from table) [kgm²]
 C_j : Compensation coefficient for allowable moment of inertia, as calculated in (2).

Allowable moment of inertia by speed and acceleration [kgm²]

WU-S: Small type

Speed Degree/s	B-axis	T-axis
	Acceleration/ deceleration	
	0.3G	0.3G
0	0.008	0.0035
150	0.008	0.0035
300	0.008	0.0035
450	0.008	0.0035
600	0.008	0.0035
750		0.0035
900		0.0035
1050		0.0035
1200		0.0025

WU-M: Medium type

Speed Degree/s	B-axis	T-axis
	Acceleration/ deceleration	
	0.3G	0.3G
0	0.0150	0.0126
150	0.0150	0.0126
300	0.0118	0.0072
450	0.0055	0.0054
600	0.0055	0.0054
750		0.0054
900		0.0036
1050		0.0036
1200		0.0036

(4) Confirmation of moment of inertia of workpiece

Using the calculations for the moment of inertia of standard object shapes (P12), calculate the moment of inertia of the tool and workpiece. Then confirm that it is less than or equal to the compensated allowable moment of inertia calculated in (3): i.e., (4) ≤ (3).

Key point
 Calculations can be done with ease by simplifying the tool and workpiece shapes.

■ If there is no load torque:

Moment of inertia applied on B-axis and T-axis.



Allowable moment of inertia for both the small and medium wrist types.*

* varies depending on speed and acceleration/deceleration.

■ Allowable moment of inertia by speed and acceleration [kgm²]

WU-S: Small type

Speed Degree/s	B-axis		T-axis	
	Acceleration/deceleration			
	0.3G	0.7G	0.3G	0.7G
0	0.0085	0.0065	0.0075	0.0035
150	0.0085	0.0065	0.0075	0.0035
300	0.0085	0.005	0.0065	0.0035
450	0.0085	0.005	0.0065	0.0025
600	0.0085	0.005	0.0065	0.0025
750		0.005	0.0065	0.0025
900			0.0065	0.0025
1050			0.0065	0.0025
1200			0.0065	0.0025

(Unit is kg · m²)

WU-M: Medium type

Speed Degree/s	B-axis		T-axis	
	Acceleration/deceleration			
	0.3G	0.7G	0.3G	0.7G
0	0.015	0.0145	0.0165	0.0126
150	0.015	0.0145	0.0165	0.0126
300	0.015	0.0127	0.0165	0.009
450	0.0099	0.0045	0.0126	0.0063
600	0.009	0.0036	0.0108	0.0054
750		0.0036	0.0099	0.0054
900		0.0036	0.0099	0.0045
1050			0.0081	0.0045
1200			0.0081	0.0045

(Unit is kg · m²)

When there is no load torque, calculate the moment of inertia of the tool and workpiece by using the calculations for the moment of inertia of standard object shapes (P12). Then confirm that it is less than or equal to the allowable moment of inertia.

Step 3

Confirmation of dynamic thrust load

Confirm that the thrust load (load applied perpendicular to the mounting surface) is less than or equal to the dynamic allowable thrust load.

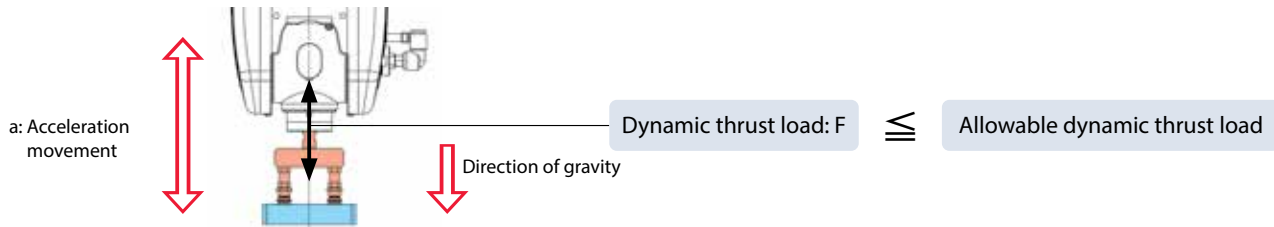

$$F = (m_t + m_w) \cdot (a + g) \cdot 9.8 [N]$$

m_t : Tooling mass [kg]
 m_w : Workpiece mass [kg]
 g : Gravitational acceleration 1.0 [G]
 a : Acceleration of movement [G]

■ Allowable dynamic thrust load

	Maximum thrust load
WU-S: Small type	330N
WU-M: Medium type	450N

Step 4

Confirmation of load moment

Confirm that the load moment is less than or equal to the allowable dynamic load.

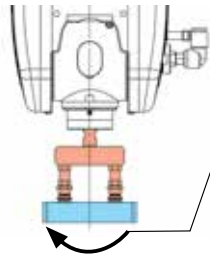

Dynamic load moment: $M \leq$ Allowable dynamic load moment

$M = m_t \cdot a \cdot 9.8(L_0 + r_{ct}) \times 10^{-3} + m_w \cdot a \cdot 9.8(L_0 + r_{cw}) \times 10^{-3}$ [Nm]

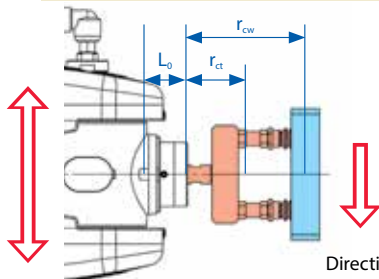

- m_t : Tooling mass [kg]
- m_w : Workpiece mass [kg]
- a : Acceleration of movement [G]
- L_0 : Load moment reference position
WU-S (small type) 17.5 [mm]
WU-M (medium type) 21.5 [mm]
- r_{ct} : Distance to tooling's center of gravity [mm]
- r_{cw} : Distance to workpiece's center of gravity [mm]

Allowable dynamic load moment

	Maximum allowable load moment
WU-S: Small type	1.4Nm
WU-M: Medium type	4.2Nm

a: Acceleration of movement

Direction of gravity

Confirmation of conditions is complete with steps 1 to 4.

Calculating the moment of inertia of standard object shapes.

1. Rotational axis is located in the center of the object

(1) Moment of inertia for a cylindrical object 1

* The same formula applies regardless of the height of the cylinder (including discs).

<Formula> $J = M \times (D \times 10^{-3})^2 / 8$

- Moment of inertia of cylinder: J (kg · m²)
- Mass of cylinder: M (unit kg)
- Diameter of cylinder: D (mm)

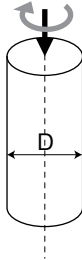

2. Center of the object is offset from the rotational axis

(4) Moment of inertia for a cylindrical object 3

* The same formula applies regardless of the height of the cylinder (including discs).

<Formula> $J = M \times (D \times 10^{-3})^2 / 8 + M \times (L \times 10^{-3})^2$

- Moment of inertia of cylinder: J (kg · m²)
- Mass of cylinder: M (kg)
- Diameter of cylinder: D (mm)
- Distance between the rotation axis and the center of gravity: L (mm)

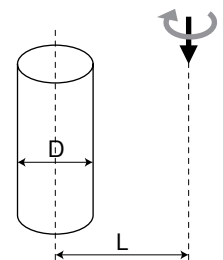

(2) Moment of inertia for a cylindrical object 2

<Formula> $J = M \times (D \times 10^{-3})^2 / 4 + (H \times 10^{-3})^2 / 3) / 4$

- Moment of inertia of cylinder: J (kg · m²)
- Mass of cylinder: M (kg)
- Diameter of cylinder: D (mm)
- Height of cylinder: H (mm)

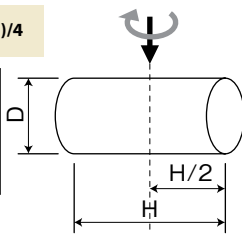

(5) Moment of inertia for a cylindrical object 4

<Formula> $J = M \times (D \times 10^{-3})^2 / 4 + (H \times 10^{-3})^2 / 3) / 4 + M \times (L \times 10^{-3})^2$

- Moment of inertia of cylinder: J (kg · m²)
- Mass of cylinder: M (kg)
- Diameter of cylinder: D (mm)
- Height of cylinder: H (mm)
- Distance between the rotation axis and the center of gravity: L (mm)

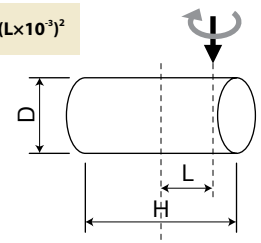

(3) Moment of inertia for a rectangular prism 1

* The same formula applies regardless of the height of the prism (including rectangular plates).

<Formula> $J = M \times (A \times 10^{-3})^2 + (B \times 10^{-3})^2) / 12$

- Moment of inertia of prism: J (kg · m²)
- Side of prism: A (mm)
- Side of prism: B (mm)

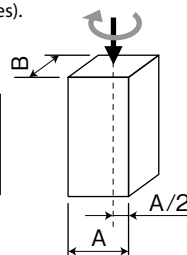

(6) Moment of inertia for a rectangular prism 2

* The same formula applies regardless of the height of the prism (including rectangular plates).

<Formula> $J = M \times (A \times 10^{-3})^2 + (B \times 10^{-3})^2) / 12 + M \times (L \times 10^{-3})^2$

- Moment of inertia of prism: J (kg · m²)
- Mass of prism: M (kg)
- Side of prism: A (mm)
- Side of prism: B (mm)
- Distance between the rotation axis and the center of gravity: L (mm)

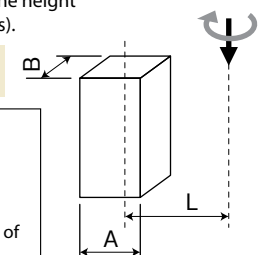

Duty

Duty ratio refers to the operating rate of the actuator (the time during which the actuator is operated in one cycle).

Note that calculating the allowable duty ratio is different for stepper motors and AC servo motors.

[Duty Ratio]
The duty ratio is the operating rate in % of the time the actuator is operating in one cycle.

$$D = \frac{T_M}{T_M + T_R} \times 100 (\%)$$

D: Duty
T_M: Operating time (including push force operation)
T_R: Stop time

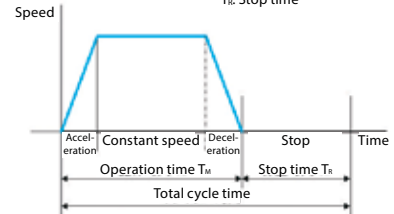

<Stepper Motor>

For the axes using a stepper motor, the actuators can be operated at a duty ration of 100%.

Type	Stepper motor axes
CRS-XBA	All axes
CRS-XBB	R-axis and BT axes
CRS-XGA	All axes
CRS-XGB	R-axis and BT- axes

Type	Stepper motor axes
CRS-XZCY	All axes
CRS-XZCZ	
CRS-XZDY	
CRS-XZDZ	
CRS-XZEY	R-axis and BT- axes
CRS-XZ EZ	

<AC servo motor>

The allowable duty ratio for AC servo motors varies depending on the operating conditions (acceleration/deceleration, etc.).

Use the Load Factor (LF) determined from the table (step 1) and the Acceleration/Deceleration time ratio (tod) calculated with the formula (step 2), to obtain the allowable duty ratio from the graph (step 3).

Type	AC servo motor axes	Type	AC servo motor axes
CRS-XBB	X-axis, Y-axis, Z-axis	CRS-XZEY	X-axis, Y-axis, Z-axis
CRS-XGB		CRS-XZEZ	

1 Determine the Load Factor by using the table "Load Factor (LF) by acceleration/deceleration" below.

* The LF assumes the maximum stroke and maximum payload for each axis.

Load Factor (LF) by acceleration/deceleration

Model	Maximum payload kg	Axis configuration	Acceleration/deceleration of each axis (G)				
			0.1	0.2	0.3	0.4	0.5
XBB	2	X-axis	21	42	62	83	—
		Y-axis	15	30	45	60	75
		Z-axis	10	20	30	40	50
XGB	2	X-axis	22	44	67	89	—
		Y-axis	15	30	45	60	75
		Z-axis	10	20	30	40	50
XZEY XZEZ	1	X-axis	18	37	55	74	92
		Y-axis	29	57	—	—	—
		Z-axis	13	26	40	53	66

2 Calculate the Acceleration/deceleration ratio, (tod) using the following formula.

$$\text{Acceleration/deceleration ratio : tod} = \frac{\text{Acceleration time} + \text{deceleration time}}{\text{Operation time}} \times 100 (\%)$$

$\text{Acceleration time} = \frac{\text{Speed (mm/s)}}{\text{Acceleration (mm/s}^2\text{)}} \text{ (second)}$	$\text{Deceleration time} = \frac{\text{Speed (mm/s)}}{\text{Deceleration (mm/s}^2\text{)}} \text{ (second)}$
$\text{Acceleration (mm/s}^2\text{)} = \text{Acceleration (G)} \times 9,800\text{mm/s}^2$	$\text{Deceleration (mm/s}^2\text{)} = \text{Deceleration (G)} \times 9,800 \text{mm/s}^2$

3 Obtain the standard duty ratio from the graph below, based on (1) LF and (2) Acceleration/deceleration time ratio.

(Ex.) When LF is 80% and acceleration/deceleration time ratio is 80%, the standard duty ratio is approx. 75%.

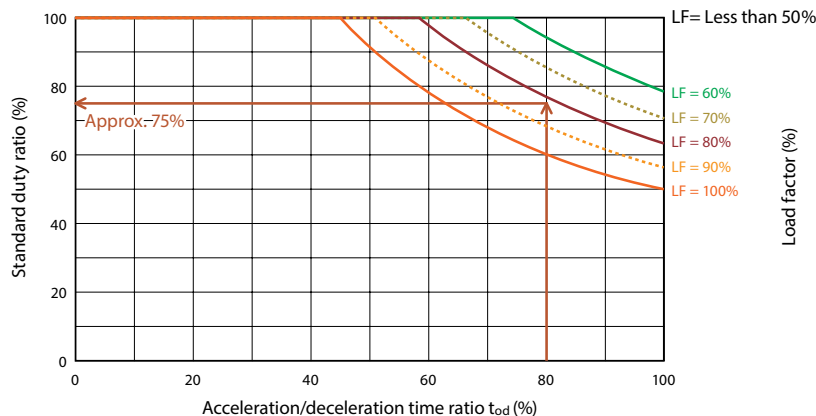

CRS-XBA

Battery-less absolute
24V stepper motor

Model specification items

CRS - XBA		WA						B		R1									
Series	Type	Configuration direction	Encoder type		1st axis (X-axis)		2nd axis (Y-axis)		3rd axis (Z-axis)		Controller		Cable length		Cable management			Options	
		1 2 3 See configuration direction	WA Battery-less absolute		Stroke 5 50mm 80 800mm (every 50mm) Options CJT CJR CJL CJB See options table below		Stroke 5 50mm 30 300mm (every 50mm)		Stroke 9 90mm 19 190mm (every 50mm) Option B Brake		R1 RSEL		1L 1m 3L 3m 5L 5m 1L ~ 15m		1st wiring 2nd wiring 3rd wiring See cable management table below			4B 5VC 5WCS See options table below	

Maximum work envelope	X-axis 800 mm	Y-axis 300 mm	Z-axis 190 mm
Max. payload	1 kg		
Standard cycle time	2.07 seconds		
Positioning repeatability	± 0.03 mm		

The standard cycle time is based on a reciprocating operation at the highest speed on the following condition.

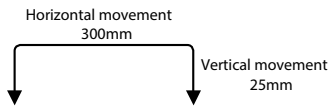

- POINT Selection Notes**
- (1) The cycle time is just a reference value. It may be higher depending on stroke and operating conditions.
 - (2) Use RSEL driver modules with the high output setting enabled.
 - (3) Positional repeatability conforms to "JIS B 8432 Manipulating industrial robots - Performance criteria and related test methods."

RoHS



(Note) The above picture shows combination direction [1] and all axes with cable tracks.

Operating directions of the rotation axis (R-axis) / Wrist axes (B-axis and T-axis)

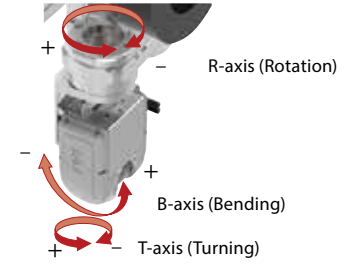

Configuration direction

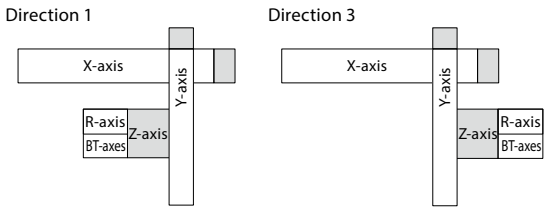

Stroke	X-axis stroke (mm)	Y-axis stroke (mm)	350~600	650~800
50~150	50~300	50~300	○	○
200~300	50~300	50~300	○	○

Cable Length

Type	Cable code	Length	R1
Standard type	1L	1m	○
	3L	3m	○
	5L	5m	○
	6L ~ 10L	6m ~ 10m	○
	11L ~ 15L	11m ~ 15m	○

(Note) Standard cables for all the axes.
 (Note) The length of cables for 2nd and 3rd axes is from the cable track exit. A robot cable is attached separately for wiring inside the cable track.
 (Note) Standard is 1m, 3m, and 5m. The length can be extended up to 15m in 1m increments.

Cable track List

Name	Type	1st wiring (X-axis)	2nd wiring (Y-axis)	3rd wiring (Z-axis)
No cable track (only cable)	N	—	—	—
Cable track S size (inside width 50mm) (Note 1)	CT	N/A	○	○
Cable track M size (inside width 63mm)	CTM	○	○	○
Cable track L size (inside width 80mm) (Note 2)	CTL	○	○	N/A
Cable track XL size (inside width 100mm) (Note 3)	CTXL	○	N/A	

(Note 1) Only 2nd and 3rd wiring can be selected.
 (Note 2) Only 1st and 2nd wiring can be selected.
 (Note 3) Only 1st wiring can be selected.

Options

Name	Option code	Ref. page	
X-axis	Direction of cable exit (standard)	Not specified	8 ○
	Direction of cable exit (top)	CJT	8 ○
	Direction of cable exit (right)	CJR	8 ○
	Direction of cable exit (left)	CJL	8 ○
	Direction of cable exit (bottom)	CJB	8 ○
Z-axis	Brake (Note 4)	B	8 standard
R-axis	Brake	4B	8 ○
B/T axes	with air joint (Note 5)	5VC	8 ○
	with wiring collar	5WCS	8 ○

(Note 4) Z-axis is equipped standard with brake. Make sure to specify it in the Z-axis option column of the model number.
 (Note 5) Adaptable tube outer diameter: φ 6mm air joint.

Main Specifications

Item	Description
Max. payload	1kg
Positioning repeatability	±0.03mm

Item	Description	
Ambient operation temperature/humidity	0-40°C, less than 85% (non-condensing)	
Degree of protection	—	
Vibration resistance/shock resistance	4.9m/s ²	
Overseas standard	RoHS	
Encoder type	Battery-less absolute	
Number of encoder pulses	XYZ axes	8192pulse/rev
	RBT axes	8192pulse/rev

Specifications of configured axes

The PTP operation enables operations at the maximum speed and maximum acceleration/deceleration.

For CP operations, refer to the reference numbers for maximum speed and acceleration/deceleration on P56.

X-axis

Item	Description	
Axis model number	RCP6-WSA14C-WA-56P-16	
Max. speed by accel/decel and stroke	Accel/decel (G)	0.1 0.2 0.3
	Stroke (mm)	50~750 800 50~750 800 50~800
	Max. speed (mm/s)	480 440 460 440 380
Stroke	Minimum stroke (mm)	50
	Maximum stroke (mm)	800
	Stroke pitch (mm)	50
Motor type	Stepper motor 56□size	

Y-axis

Item	Description	
Axis model number	RCP6-WSA12C-WA-42P-12	
Speed/accel/decel	Accel/decel (G)	0.1 0.2 0.3
	Max. speed (mm/s)	400 400 400
Stroke	Minimum stroke (mm)	50
	Maximum stroke (mm)	300
	Stroke pitch (mm)	50
Motor type	Stepper motor 42□size	

Z-axis

Item	Description	
Axis model number	RCP6-TA7R-WA-56P-4□-B-DB	
Speed/accel/decel	Accel/decel (G)	0.1 0.2 0.3
	Max. speed (mm/s)	175 140 140
Stroke	Minimum stroke (mm)	90
	Maximum stroke (mm)	190
	Stroke pitch (mm)	50
Motor type	Stepper motor 56□size	

R-axis

Item	Description	
Axis model number	RCP6-RTFML-WA-42P-30-360	
Speed/accel/decel	Accel/decel (G) (Note 6)	0.3
	Max. speed (degree/s)	800
Operation range (degree)	±180	
Maximum torque (N · m) (Note 7)	5.2	
Maximum allowable moment of inertia (kg · m ²) (Note 7)	0.08	
Motor type	Stepper motor 42□size	

(Note 6) 1G ≒ 9807 degrees/s²

(Note 7) Varies depending on speed and accel/decel. See P55 for details.

BT-axis

Item	Description		
Axis configuration	B-axis (wrist bending) T-axis (wrist turning)		
Axis model number	WU-S-WA		
Speed/accel/decel	Accel/decel (G) (Note 8)	0.3 0.3	
	Max. speed (degree/s)	Single operation	750 1200
		B&T axes simultaneous op.	600 600
Operation range (degree)	±100 ±360		
Motor type	Stepper motor 28□size		
Maximum torque (N · m) (Note 9)	0.65 0.65		
Maximum allowable moment of inertia (kg · m ²) (Note 9)	0.0085 0.0075		

(Note 8) 1G ≒ 9807 degrees/s²

(Note 9) Varies depending on speed and accel/decel. See P55 for details.

(Note) B&T axes are equipped standard with a brake.

Dimensions

*1 The cable track can swell and may become slightly larger than the size in the drawing.
 (Note) The drawing below shows all actuators in the home position.
 (Note) The drawing below shows the combination direction [1] with cable tracks for the 1st, 2nd, and 3rd axis wiring.

CAD drawings can be downloaded from our website.
www.intelligentactuator.com

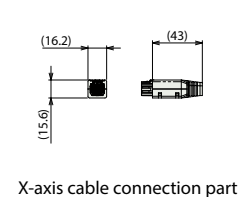
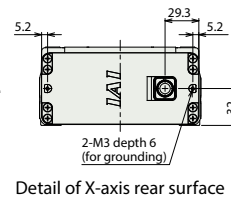
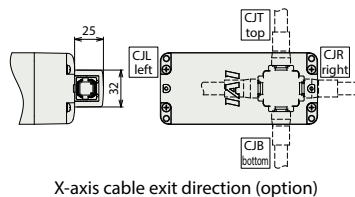
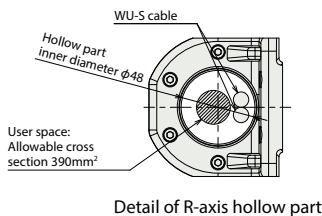
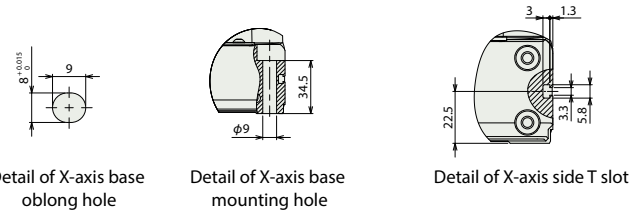
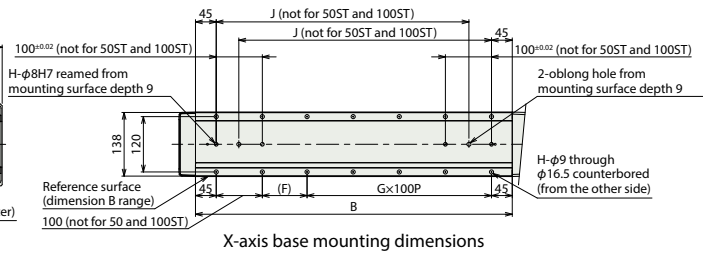
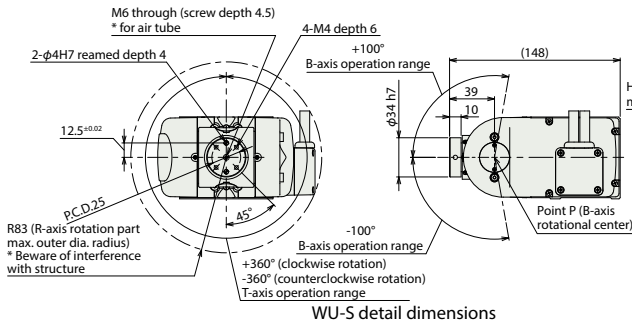
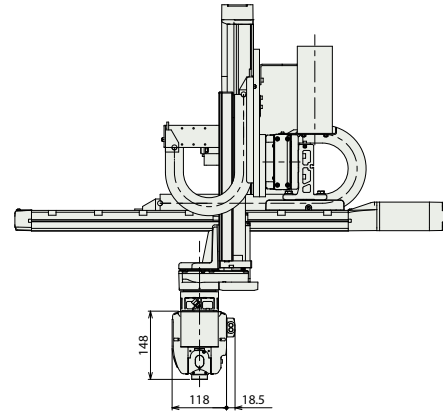
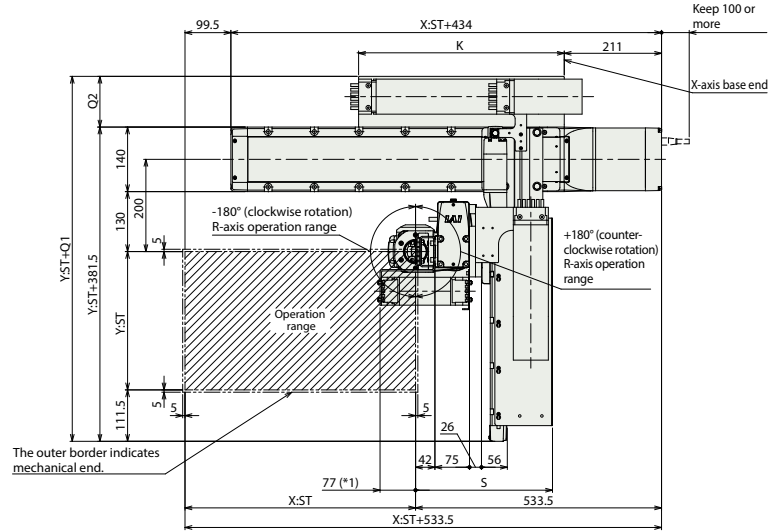
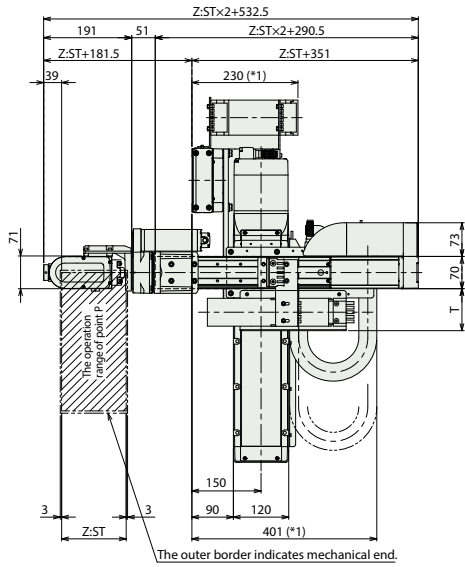

■ Dimensions by stroke

X-axis stroke	50	100	150	200	250	300	350	400	450	500	550	600	650	700	750	800
B	237	287	337	387	437	487	537	587	637	687	737	787	837	887	937	987
F	147	197	47	97	47	97	47	97	47	97	47	97	47	97	47	97
G	0	0	1	1	2	2	3	3	4	4	5	5	6	6	7	7
H	4	4	8	8	10	10	12	12	14	14	16	16	18	18	20	20
J	—	—	198	248	298	348	398	448	498	548	598	648	698	748	798	848
K	221	246	271	296	321	346	371	396	421	446	471	496	521	546	571	596
M	2	2	4	4	4	4	4	4	4	4	4	4	4	4	4	4

Cable track size	CT	CTM	CTL	CTXL
Q1	—	491.5	508.5	528.5
Q2	—	110	127	147
S	286	297	314	—
T	91	102	—	—

(Note) Dimensions of Q1, Q2, S and T vary depending on the cable track size.

■ Cartesian system mass by stroke

X-axis stroke (mm)	50~300	350~600	650~800
Y-axis stroke (mm)	50~150	32~37	36~40
200~300	34~38	37~42	41~44

(Note) Refer to the installation manual for how to calculate the mass of the Cartesian system. (unit: kg)

Cable track cross section

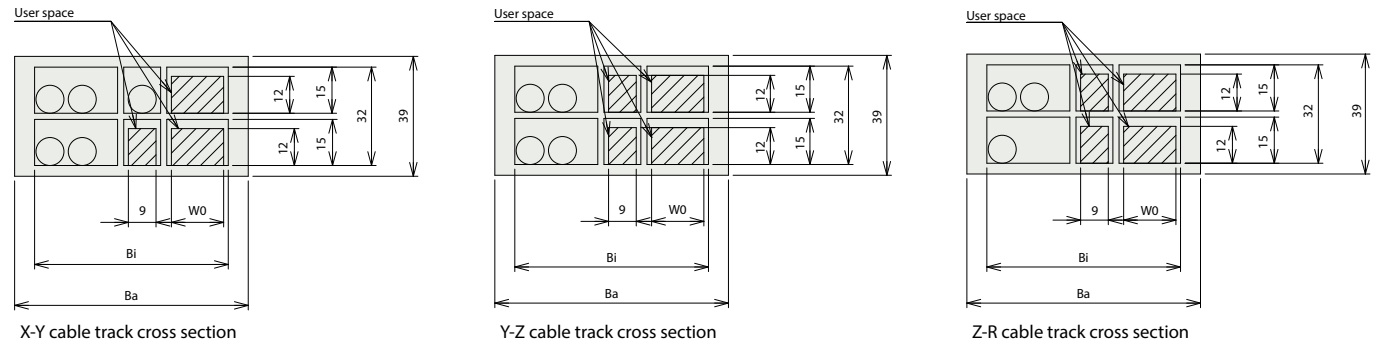

Cable track size	CT	CTM	CTL	CTXL
Cable track model number	B17.4.075.0	B17.5.075.0	B17.6.075.0	B17.7.075.0
Ba	60.5	76	93	113
Bi	50	63	80	100
W0	9	17	34	54

Applicable controller

The actuators on this page are operable by the following controller. Select a type suitable for your use.

Name	Ext. appearance	Max. connectable axes	Voltage	Control method													Max. positioning points	Reference page				
				Positioner	Pulse-train	Program	Network *Select															
RSEL-SXBA (for CRS)		8	DC24V	—	—	●	DV	CC	CIE	PR	CN	ML	ML3	EC	EP	PRT	SSN	ECM	—	—	36000	57

(Note) See P58 for the network codes, such as DV and CC.

CRS-XBB

Battery-less absolute
24V stepper motor
200V AC servo motor

Model specification items

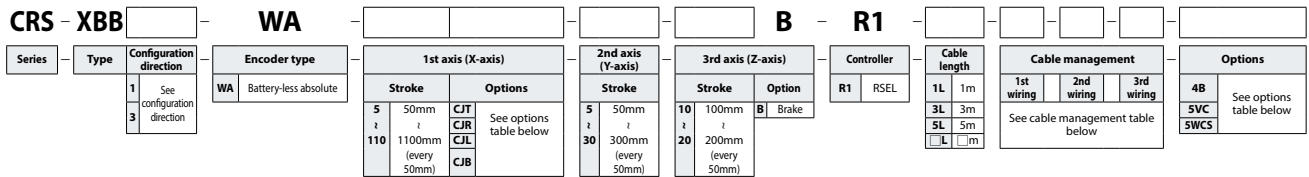

Maximum work envelope	X-axis 1100 mm	Y-axis 300 mm	Z-axis 200 mm
Max. payload	2 kg		
Standard cycle time	1.66 seconds		
Positioning repeatability	± 0.03 mm		

The standard cycle time is based on a reciprocating operation at the highest speed on the following condition.

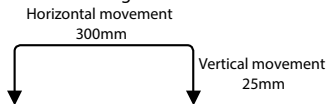

POINT Selection Notes	(1) The cycle time is just a reference value. It may be higher depending on stroke and operating conditions.
	(2) The allowable duty ratio varies depending on operating conditions (payload, acceleration/deceleration, etc.). See P13 for details.
	(3) For the R-axis and the BT axes, use RSEL driver modules with the high output setting enabled.
	(4) Positional repeatability conforms to "JIS B 8432 Manipulating industrial robots - Performance criteria and related test methods."

RoHS



(Note) The above picture shows combination direction [1] and all axes with cable tracks.

Operating directions of the rotation axis (R-axis) / Wrist axes (B-axis and T-axis)

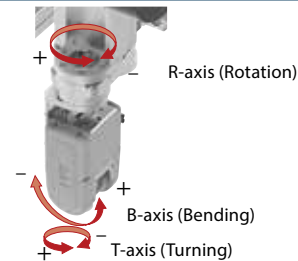

Direction of combination

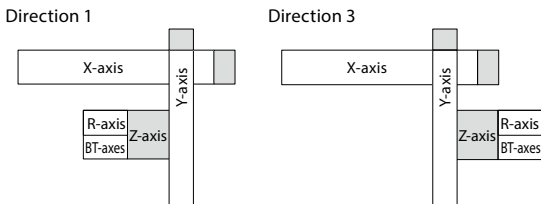

Stroke

X-axis stroke (mm)	50~300	350~600	650~800	850~1100
Y-axis stroke (mm)				
50~150	<input type="radio"/>	<input type="radio"/>	<input type="radio"/>	<input type="radio"/>
200~300	<input type="radio"/>	<input type="radio"/>	<input type="radio"/>	<input type="radio"/>

Cable Length

Type	Cable code	Length	R1
Standard type	1L	1m	<input type="radio"/>
	3L	3m	<input type="radio"/>
	5L	5m	<input type="radio"/>
	6L ~ 10L	6m ~ 10m	<input type="radio"/>
	11L ~ 15L	11m ~ 15m	<input type="radio"/>

(Note) Standard cables for all the axes.

(Note) The length of cables for 2nd and 3rd axes is from the cable track exit.

A robot cable is attached separately for wiring inside the cable track.

(Note) Standard is 1m, 3m, and 5m. The length can be extended up to 15m in 1m increments.

Cable Management List

Name	Type	1st wiring (X-axis)	2nd wiring (Y-axis)	3rd wiring (Z-axis)
No cable track (only cable)	N	—	—	—
Cable track S size (inside width 50mm) (Note 4)	CT	N/A	<input type="radio"/>	<input type="radio"/>
Cable track M size (inside width 63mm)	CTM	<input type="radio"/>	<input type="radio"/>	<input type="radio"/>
Cable track L size (inside width 80mm)	CTL	<input type="radio"/>	<input type="radio"/>	<input type="radio"/>
Cable track XL size (inside width 100mm) (Note 5)	CTXL	<input type="radio"/>	N/A	

(Note 1) Only 2nd and 3rd wiring can be selected.

(Note 2) Only 1st wiring can be selected.

Option * Please check the Options reference pages to confirm each option.

Name	Option code	Ref. page	
X-axis	Direction of cable exit (top) (Note 3)	CJT	8 <input type="radio"/>
	Direction of cable exit (right) (Note 3)	CJR	8 <input type="radio"/>
	Direction of cable exit (left) (Note 3)	CJL	8 <input type="radio"/>
	Direction of cable exit (bottom) (Note 3)	CJB	8 <input type="radio"/>
Z-axis	Brake (Note 4)	B	8 standard <input type="radio"/>
R-axis	Brake	4B	8 <input type="radio"/>
B/T axes	with air joint (Note 5)	5VC	8 <input type="radio"/>
	with wiring collar	5WCS	8 <input type="radio"/>

(Note 3) Make sure to specify one of codes at the option column of the model number.

(Note 4) Z-axis is equipped standard with brake. Make sure to specify it in the Z-axis option column of the model number.

(Note 5) Applicable tube outer diameter: φ 6mm air joint.

Main Specifications

Item	Description
Max. payload	2kg
Positioning repeatability	±0.03mm

Item	Description	
Ambient operation temperature/humidity	0-40°C , less than 85% (non-condensing)	
Degree of protection	—	
Vibration resistance/shock resistance	4.9m/s ²	
Overseas standard	RoHS	
Encoder type	Battery-less absolute	
Number of encoder pulses	XYZ axes	16384pulse/rev
	RBT axes	8192pulse/rev

Specifications of configured axes

The PTP operation enables operations at the maximum speed and maximum acceleration/deceleration.

For CP operations, refer to the reference numbers for maximum speed and acceleration/deceleration on P56.

X-axis

Item	Description	
Axis model number	RCS4-WSA16C-WA-400-20	
Max. speed by accel/ decel and stroke	Accel/decel (G)	0.4
	Stroke (mm)	50-550
Stroke	Max. speed (mm/s)	1200 1120 990 880 780 715 645 590 535 490 450 415
	Minimum stroke (mm)	50
	Maximum stroke (mm)	1100
	Stroke pitch (mm)	50
	Motor type	AC servo motor 400W

Y-axis

Item	Description	
Axis model number	RCS4-WSA14C-WA-200-16	
Speed/accel/ decel	Accel/decel (G)	0.5
	Max. speed (mm/s)	960
Stroke	Minimum stroke (mm)	50
	Maximum stroke (mm)	300
	Stroke pitch (mm)	50
Motor type	AC servo motor 200W	

Z-axis

Item	Description	
Axis model number	RCS4-SA8R-WA-400-10-□-B-W (double slider spec.)	
Speed/ accel/ decel	Accel/decel (G)	0.5
	Max. speed (mm/s)	600
Stroke	Minimum stroke (mm)	100
	Maximum stroke (mm)	200
	Stroke pitch (mm)	50
Motor type	AC servo motor 400W	

R-axis

Item	Description	
Axis model number	RCP6-RTFML-WA-42P-30-360	
Speed/accel/ decel	Accel/decel (G) (Note 6)	0.3
	Max. speed (degree/s)	800
Operation range (degree)	±180	
Maximum torque (N · m) (Note 7)	5.2	
Maximum allowable moment of inertia (kg · m ²) (Note 7)	0.08	
Motor type	Stepper motor 42□size	

(Note 6) 1G ≒ 9807 degrees/s²

(Note 7) Varies depending on speed and accel/decel. See P55 for details.

BT-axis

Item	Description	
Axis configuration	B-axis (wrist bending)	T-axis (wrist turning)
Axis model number	WU-M-WA	
Speed/accel/ decel	Accel/decel (G) (Note 8)	0.3 0.3
	Max. speed (degree/s)	Single operation 900 1200 B&T axes simultaneous op. 600 600
Operation range (degree)	±105	±360
Motor type	Stepper motor 35□size	
Maximum torque (N · m) (Note 9)	1.65	1.65
Maximum allowable moment of inertia (kg · m ²) (Note 9)	0.015	0.0165

(Note 8) 1G ≒ 9807 degrees/s²

(Note 9) Varies depending on speed and accel/decel. See P55 for details.

(Note) B&T axes are equipped standard with a brake.

Dimensions

*1 The cable track can swell and may become slightly larger than the size in the drawing.
 (Note) The drawing below shows all actuators in the home position.
 (Note) The drawing below shows the combination direction [1] with cable tracks for the 1st, 2nd, and 3rd axis wiring.

CAD drawings can be downloaded from our website.
www.intelligentactuator.com

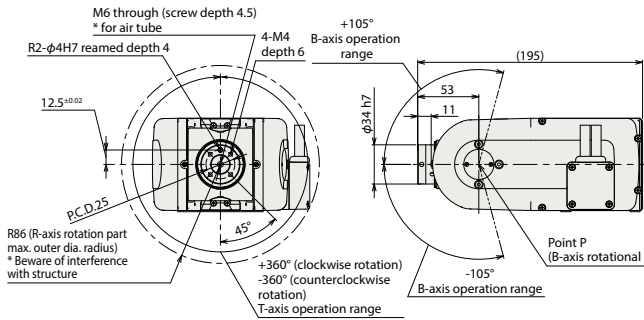
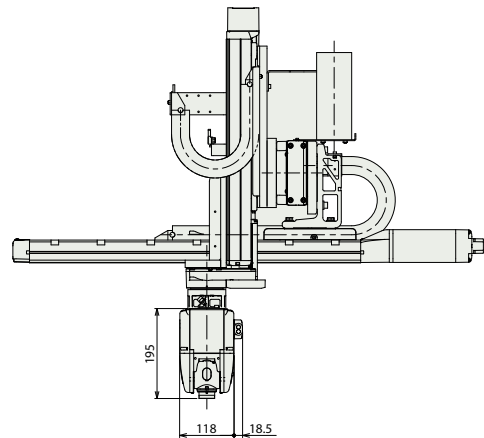
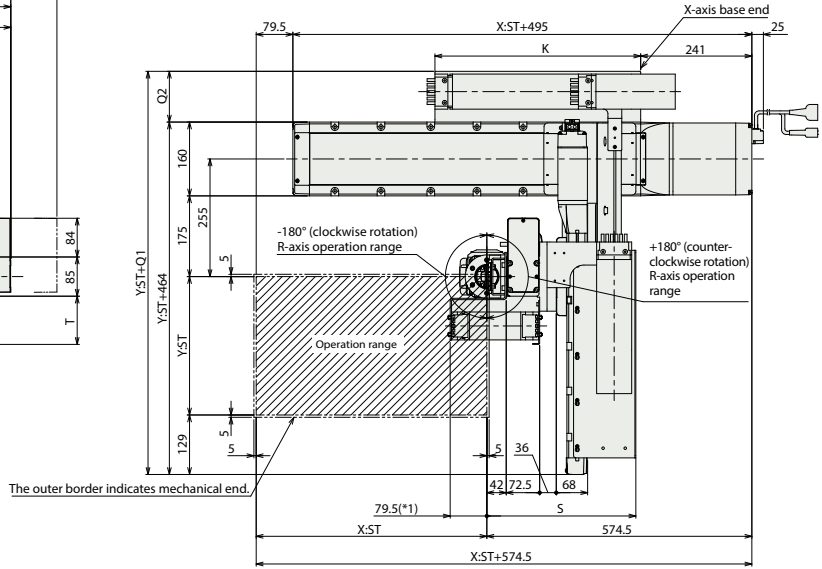
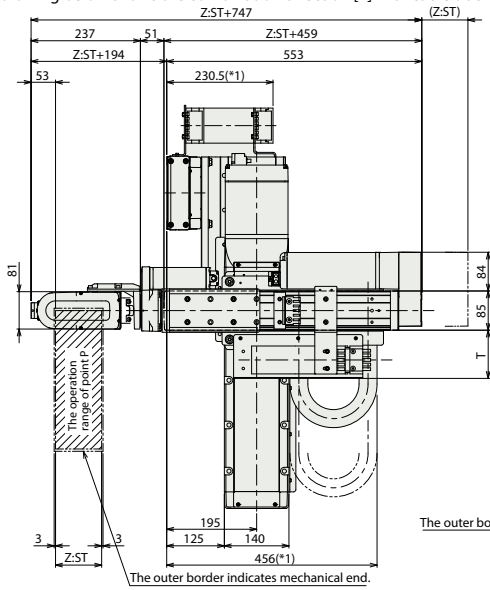

WU-M detail dimensions

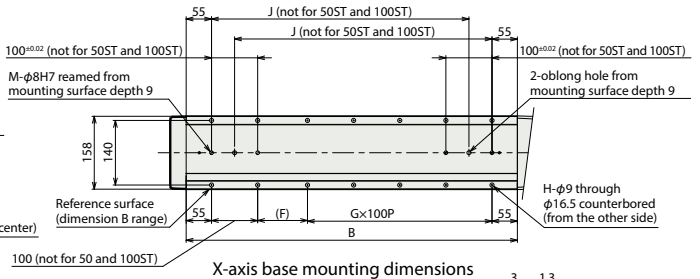

Detail of X-axis base oblong hole

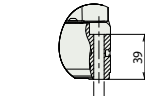

Detail of X-axis base mounting hole

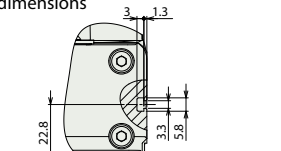

Detail of X-axis side T slot

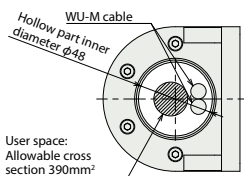

Detail of R-axis hollow part

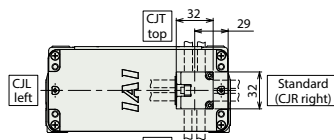

Cable exit direction (option)
 * Standard cable exit direction is right (CJR).

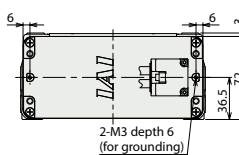

Detail of X-axis rear surface

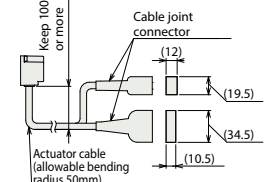

X-axis pigtail cable connection

Dimensions by stroke

X-axis stroke	50	100	150	200	250	300	350	400	450	500	550	600	650	700	750	800	850	900	950	1000	1050	1100
B	268	318	368	418	468	518	568	618	668	718	768	818	868	918	968	1018	1068	1118	1168	1218	1268	1318
F	158	208	58	108	58	108	58	108	58	108	58	108	58	108	58	108	58	108	58	108	58	108
G	0	0	1	1	2	2	3	3	4	4	5	5	6	6	7	7	8	8	9	9	10	10
H	4	4	8	8	10	10	12	12	14	14	16	16	18	18	20	20	22	22	24	24	26	26
J	—	—	208	258	308	358	408	458	508	558	608	658	708	758	808	858	908	958	1008	1058	1108	1158
K	221	246	271	296	321	346	371	396	421	446	471	496	521	546	571	596	621	646	671	696	721	746
M	2	2	4	4	4	4	4	4	4	4	4	4	4	4	4	4	4	4	4	4	4	4

Cable track size	CT	CTM	CTL	CTXL
Q1	—	574	591	611
Q2	—	110	127	147
S	312	323	340	—
T	104.5	115.5	132.5	—

(Note) Dimensions of Q1, Q2, S and T vary depending on the cable track size.

Cartesian system mass by stroke

X-axis stroke (mm)	50~400	450~800	850~1100
Y-axis stroke (mm)			
50~150	46~53	52~59	58~64
200~300	48~55	54~61	60~66

(Note) Refer to the installation manual for how to calculate the mass of the Cartesian system. (unit: kg)

Cable track cross section

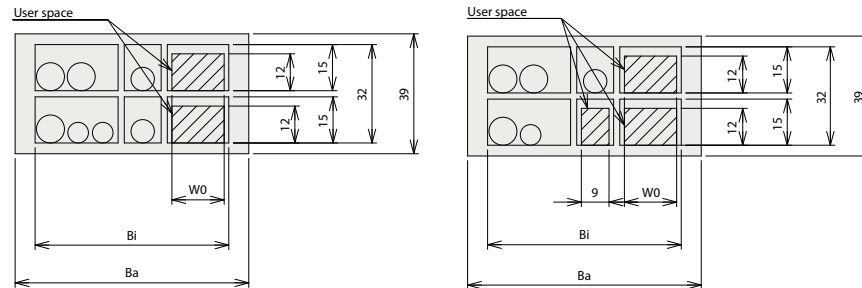

X-Y cable track cross section

Y-Z cable track cross section
Z-R cable track cross section

Cable track size	CT	CTM	CTL	CTXL
Cable track model number	B17.4.075.0	B17.5.075.0	B17.6.075.0	B17.7.075.0
Ba	60.5	76	93	113
Bi	50	63	80	100
W0	9	17	34	54

Applicable controller

The actuators on this page are operable by the following controller. Select a type suitable for your use.

Name	Ext. appearance	Max. connectable axes	Voltage	Positioner	Pulse-train	Program	Control method											Max. positioning points	Reference page	
							Network *Select													
							DV	CC	CIE	PR	CN	ML	ML3	EC	EP	PRT	SSN	ECM		
RSEL-SXBB (for CRS)		8	DC24V single-phase 200VAC three-phase 200VAC	—	—	●	●	●	●	●	—	—	—	●	●	●	—	—	36000	57

(Note) See P58 for the network codes, such as DV and CC.

CRS-XGA

Battery-less absolute
24V stepper motor

Model specification items

CRS - XGA		WA						B		R1								
Series	Type	Configuration direction	Encoder type	1st axis (X-axis)		2nd axis (Y-axis)		3rd axis (Z-axis)		Controller		Cable length		Cable management			Options	
		1 See configuration direction 3	WA Battery-less absolute	Stroke		Stroke		Stroke		R1	RSEL	1L 1m 3L 3m 5L 5m 1L 1m	1st wiring 2nd wiring 3rd wiring	See cable management table below			4B See options table below 5VC 5WCS	
				5 50mm 80 800mm (every 50mm)	CJT CJR CJL CJB	35 350mm 60 600mm (every 50mm)		9 90mm 19 190mm (every 50mm)	B Brake									

Maximum work envelope	X-axis 800 mm	Y-axis 600 mm	Z-axis 190 mm
Max. payload	1 kg		
Standard cycle time	2.11 seconds		
Positioning repeatability	± 0.03 mm		

The standard cycle time is based on a reciprocating operation at the highest speed on the following condition.

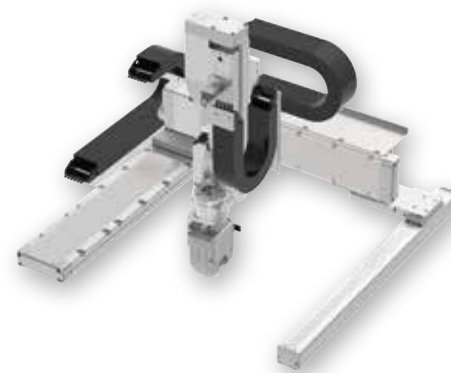
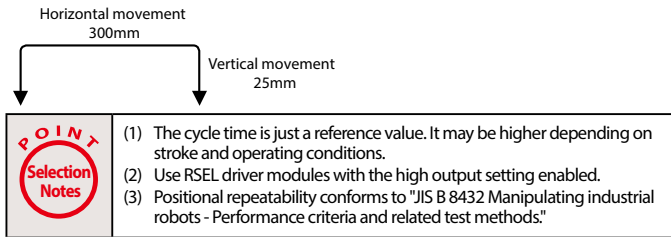

RoHS

(Note) The above picture shows combination direction [1] and all axes with cable track.

Operating directions of the rotation axis (R-axis) / Wrist axes (B-axis and T-axis)

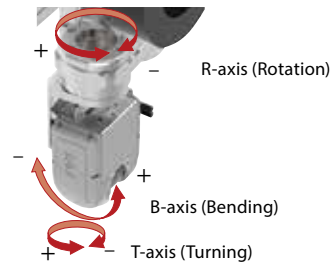

Configuration direction

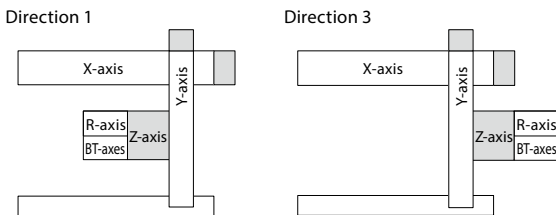

Stroke

X-axis stroke (mm)	50~300	350~600	650~800
Y-axis stroke (mm)			
350~450	<input type="radio"/>	<input type="radio"/>	<input type="radio"/>
500~600	<input type="radio"/>	<input type="radio"/>	<input type="radio"/>

Cable Length

Type	Cable code	Length	R1
Standard type	1L	1m	<input type="radio"/>
	3L	3m	<input type="radio"/>
	5L	5m	<input type="radio"/>
	6L ~ 10L	6m ~ 10m	<input type="radio"/>
	11L ~ 15L	11m ~ 15m	<input type="radio"/>

(Note) Standard cables for all the axes.
 (Note) The length of cables for 2nd and 3rd axes is from the cable track exit.
 A robot cable is attached separately for wiring inside the cable track.
 (Note) Standard is 1m, 3m, and 5m. The length can be extended up to 15m in 1m increments.

Cable Management List

Name	Type	1st wiring (X-axis)	2nd wiring (Y-axis)	3rd wiring (Z-axis)
No cable track (only cable)	N	—	—	—
Cable track S size (inside width 50mm) (Note 1)	CT	N/A	<input type="radio"/>	<input type="radio"/>
Cable track M size (inside width 63mm)	CTM	<input type="radio"/>	<input type="radio"/>	<input type="radio"/>
Cable track L size (inside width 80mm) (Note 2)	CTL	<input type="radio"/>	<input type="radio"/>	N/A
Cable track XL size (inside width 100mm) (Note 3)	CTXL	<input type="radio"/>	N/A	

(Note 1) Only 2nd and 3rd wiring can be selected.
 (Note 2) Only 1st and 2nd wiring can be selected.
 (Note 3) Only 1st wiring can be selected.

Option

* Please check the Options reference pages to confirm each option.

Name	Option code	Ref. page	
X-axis	Direction of cable exit (standard)	Not specified	8 <input type="radio"/>
	Direction of cable exit (top)	CJT	8 <input type="radio"/>
	Direction of cable exit (right)	CJR	8 <input type="radio"/>
	Direction of cable exit (left)	CJL	8 <input type="radio"/>
	Direction of cable exit (bottom)	CJB	8 <input type="radio"/>
Z-axis	Brake (Note 4)	B	8 standard
R-axis	Brake	4B	8 <input type="radio"/>
B/T axes	with air joint (Note 5)	5VC	8 <input type="radio"/>
	with wiring collar	5WCS	8 <input type="radio"/>

(Note 4) Z-axis is equipped standard with brake. Make sure to specify it in the Z-axis option column of the model number.
 (Note 5) Applicable tube outer diameter: φ6mm air joint.

Main Specifications

Item	Description
Max. payload	1kg
Positioning repeatability	±0.03mm

Item	Description
Ambient operation temperature/humidity	0-40°C, less than 85% (non-condensing)
Degree of protection	—
Vibration resistance/shock resistance	4.9m/s ²
Overseas standard	RoHS
Encoder type	Battery-less absolute
Number of encoder pulses	XYZ axes
	RBT axes

Specifications of configured axes

The PTP operation enables operations at the maximum speed and maximum acceleration/deceleration.

For CP operations, refer to the reference numbers for maximum speed and acceleration/deceleration on P56.

X-axis

Item	Description
Axis model number	RCP6-WSA14LC-WA-56P-16 (long slider spec.)
Max. speed by accel/decel and stroke	Accel/decel (G)
	Stroke (mm)
	Max. speed (mm/s)
Stroke	Minimum stroke (mm)
	Maximum stroke (mm)
	Stroke pitch (mm)
	Motor type

Y-axis

Item	Description
Axis model number	RCP6-WSA12C-WA-42P-12
Speed/accel/decel	Accel/decel (G)
	Max. speed (mm/s)
	Stroke
Stroke	Minimum stroke (mm)
	Maximum stroke (mm)
	Stroke pitch (mm)
Motor type	

Z-axis

Item	Description
Axis model number	RCP6-TA7R-WA-56P-4-□-B-DB
Speed/accel/decel	Accel/decel (G)
	Max. speed (mm/s)
	Stroke
Stroke	Minimum stroke (mm)
	Maximum stroke (mm)
	Stroke pitch (mm)
Motor type	

R-axis

Item	Description
Axis model number	RCP6-RTFML-WA-42P-30-360
Speed/accel/decel	Accel/decel (G) (Note 6)
	Max. speed (degree/s)
Operation range (degree)	±180
Maximum torque (N · m) (Note 7)	5.2
Maximum allowable moment of inertia (kg · m ²) (Note 7)	0.08
Motor type	Stepper motor 42□size

(Note 6) 1G ≙ 9807 degrees/s²

(Note 7) Varies depending on speed and accel/decel. See P55 for details.

BT-axis

Item	Description
Axis configuration	B-axis (wrist bending) T-axis (wrist turning)
Axis model number	WU-S-WA
Speed/accel/decel	Accel/decel (G) (Note 8)
	Max. speed (degree/s)
	Operation range (degree)
Motor type	Stepper motor 28□size
Maximum torque (N · m) (Note 9)	0.65
Maximum allowable moment of inertia (kg · m ²) (Note 9)	0.0085

(Note 8) 1G ≙ 9807 degrees/s²

(Note 9) Varies depending on speed and accel/decel. See P55 for details.

(Note) B&T axes are equipped standard with a brake.

Dimensions

- *1 The cable track can swell and may become slightly larger than the size in the drawing.
- (Note) The assembled drawing is the home position.
- (Note) The drawing below shows the combination direction [1] with cable tracks for the 1st, 2nd, and 3rd axis wiring.
- (Note) The screw hole on the bottom surface of the driven axis is for the purpose of packing. Do not use it for installation.

CAD drawings can be downloaded from our website.
www.intelligentactuator.com

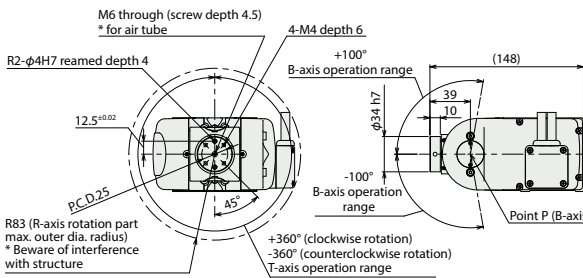
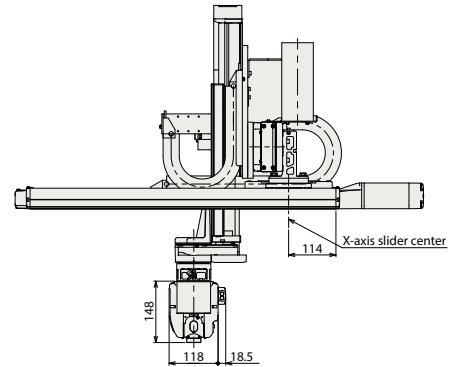
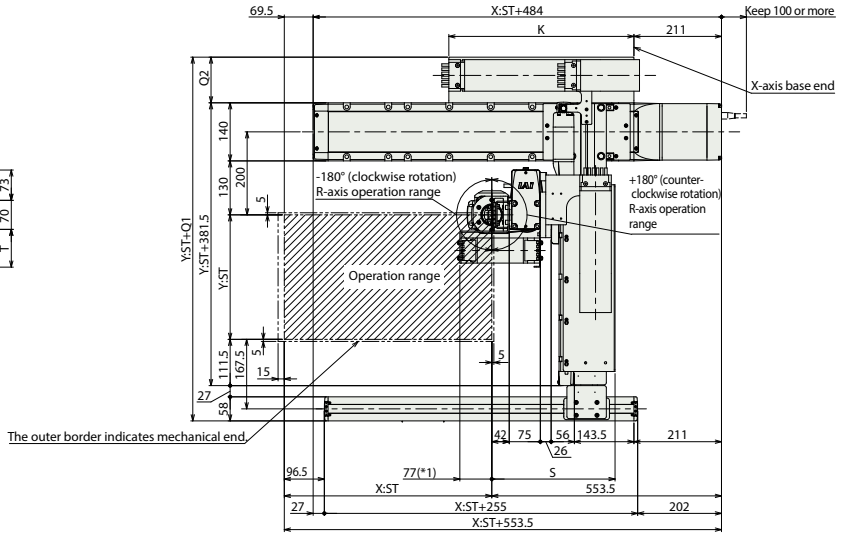
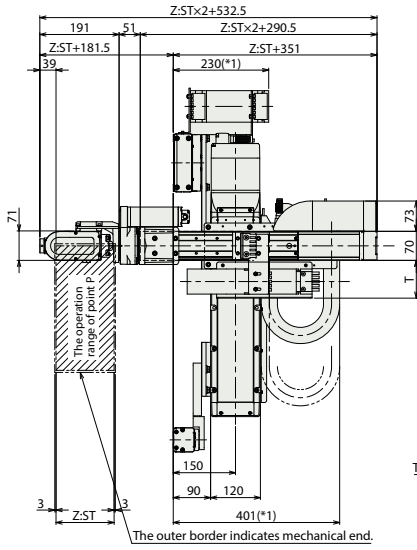

WU-S detail dimensions

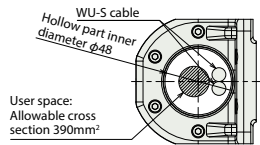

Detail of R-axis hollow part

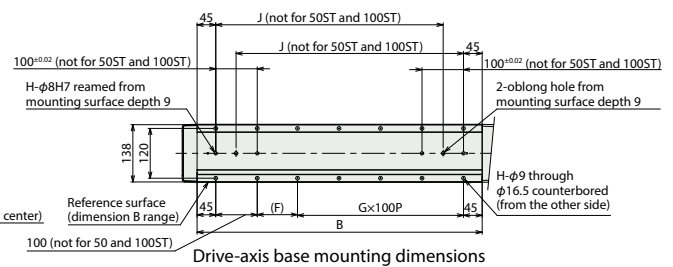

Drive-axis base mounting dimensions

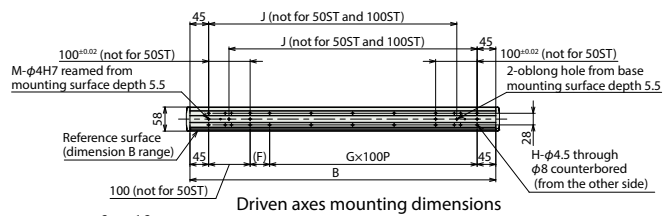

Driven axes mounting dimensions



Detail of drive-axis base oblong hole



Detail of drive-axis base mounting hole

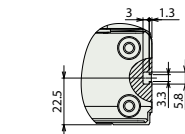

Detail of X-axis side T slot

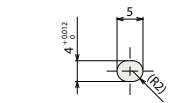

Detail of driven-axis base oblong hole

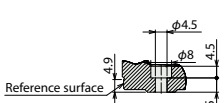

Detail of driven-axis base mounting hole

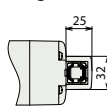

X-axis cable exit direction (option)

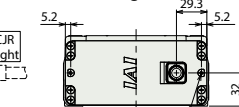

Detail of X-axis rear surface

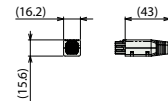

X-axis cable connection part

■ Dimensions by stroke

X-axis stroke	50	100	150	200	250	300	350	400	450	500	550	600	650	700	750	800
B	287	337	387	437	487	537	587	637	687	737	787	837	887	937	987	1037
F	197	47	97	47	97	47	97	47	97	47	97	47	97	47	97	47
G	0	1	1	2	2	3	3	4	4	5	5	6	6	7	7	8
H	4	8	8	10	10	12	12	14	14	16	16	18	18	20	20	22
J	—	198	248	298	348	398	448	498	548	598	648	698	748	798	848	898
K	221	246	271	296	321	346	371	396	421	446	471	496	521	546	571	596
M	2	4	4	4	4	4	4	4	4	4	4	4	4	4	4	4

Cable track size	CT	CTM	CTL	CTXL
Q1	—	576.5	593.5	613.5
Q2	—	110	127	147
S	286	297	314	—
T	91	102	—	—

(Note) Dimensions of Q1, Q2, S and T vary depending on the cable track size.

■ Cartesian system mass by stroke

X-axis stroke (mm)	50~300	350~600	650~800	
Y-axis stroke (mm)	350~600	40~47	44~51	50~54

(Note) Refer to the installation manual for how to calculate the mass of the Cartesian system. (unit: kg)

Cable track cross section

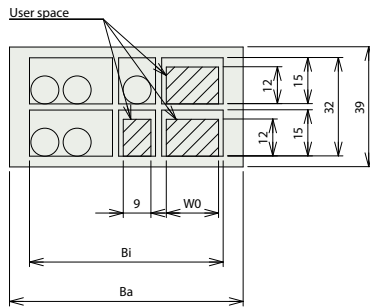

X-Y cable track cross section

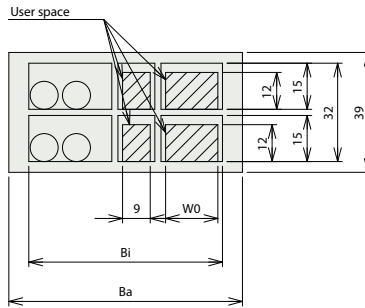

Y-Z cable track cross section

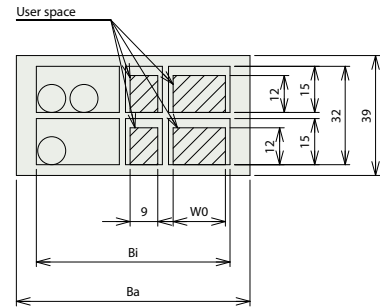

Z-R cable track cross section

Cable track size	CT	CTM	CTL	CTXL
Cable track model number	B17.4.075.0	B17.5.075.0	B17.6.075.0	B17.7.075.0
Ba	60.5	76	93	113
Bi	50	63	80	100
W0	9	17	34	54

Applicable controller

The actuators on this page are operable by the following controller. Select a type suitable for your use.

Name	Ext. appearance	Max. connectable axes	Voltage	Positioner	Pulse-train	Program	Control method													Max. positioning points	Reference page
							Network *Select														
RSEL-SXGA (for CRS)		8	DC24V	—	—	●	DV	CC	CIE	PR	CN	ML	ML3	EC	EP	PRT	SSN	ECM	36000	57	

(Note) See P58 for the network codes, such as DV and CC.

CRS-XGB

Battery-less absolute
24V stepper motor
200V AC servo motor

Model specification items

CRS - XGB		WA								B		R1							
Series	Type	Configuration direction	Encoder type		1st axis (X-axis)		2nd axis (Y-axis)		3rd axis (Z-axis)		Controller		Cable length		Cable management			Options	
		1 3	WA Battery-less absolute		Stroke Options		Stroke		Stroke Option		R1 RSEL		1L 1m 3L 3m 5L 5m 11L 11m		1st wiring 2nd wiring 3rd wiring			4B 5VC 5WCS	
		See configuration direction			5 50mm 110 1100mm (every 50mm) CJT CJR CJL CJB		35 350mm 60 600mm (every 50mm)		10 100mm 20 200mm (every 50mm) B Brake						See cable management table below			See options table below	

Maximum work envelope	X-axis 1100 mm	Y-axis 600 mm	Z-axis 200 mm
Max. payload	2 kg		
Standard cycle time	1.66 seconds		
Positioning repeatability	± 0.04 mm		

The standard cycle time is based on a reciprocating operation at the highest speed on the following condition.

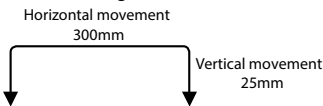

- POINT Selection Notes**
- (1) The cycle time is just a reference value. It may be higher depending on stroke and operating conditions.
 - (2) The duty guide number varies depending on operating conditions (payload, acceleration/deceleration, etc.). See P13 for details.
 - (3) Use RSEL drive unit of the R-axis and BT axes with the high output setting "Enable."
 - (4) Positional repeatability conforms to "JIS B 8432 Manipulating industrial robots - Performance criteria and related test methods."

RoHS

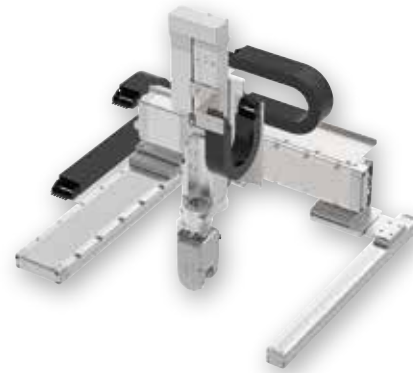

(Note) The above picture shows combination direction [1] and all axes with cable track.

Operating directions of the rotation axis (R-axis) / Wrist axes (B-axis and T-axis)

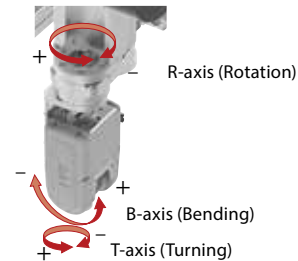

Configuration direction

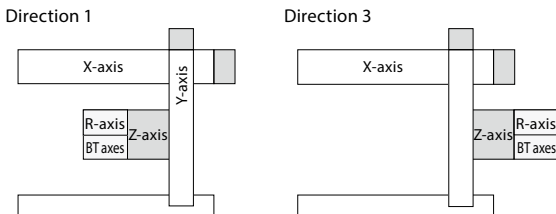

Stroke

X-axis stroke (mm)	50~300	350~600	650~800	850~1100
Y-axis stroke (mm)				
350~450	<input type="radio"/>	<input type="radio"/>	<input type="radio"/>	<input type="radio"/>
500~600	<input type="radio"/>	<input type="radio"/>	<input type="radio"/>	<input type="radio"/>

Cable Length

Type	Cable code	Length	R1
Standard type	1L	1m	<input type="radio"/>
	3L	3m	<input type="radio"/>
	5L	5m	<input type="radio"/>
	6L ~ 10L	6m ~ 10m	<input type="radio"/>
	11L ~ 15L	11m ~ 15m	<input type="radio"/>

(Note) Standard cables for all the axes.

(Note) The length of cables for 2nd and 3rd axes is from the cable track exit.

A robot cable is attached separately for wiring inside the cable track.

(Note) Standard is 1m, 3m, and 5m. The length can be extended up to 15m in 1m increments.

Option

* Please check the Options reference pages to confirm each option.

	Name	Option code	Ref. page	
X-axis	Direction of cable exit (top) (Note 3)	CJT	8	<input type="radio"/>
	Direction of cable exit (right) (Note 3)	CJR	8	<input type="radio"/>
	Direction of cable exit (left) (Note 3)	CJL	8	<input type="radio"/>
	Direction of cable exit (bottom) (Note 3)	CJB	8	<input type="radio"/>
Z-axis	Brake (Note 4)	B	8	standard
R-axis	Brake	4B	8	<input type="radio"/>
B/T axes	with air joint (Note 5)	5VC	8	<input type="radio"/>
	with wiring collar	5WCS	8	<input type="radio"/>

(Note 3) Make sure to specify one of codes at the option column of the model specification item.

(Note 4) Z-axis is equipped standard with brake. Make sure to specify it in the Z-axis option column of the model number.

(Note 5) Applicable tube outer diameter: φ6mm air joint.

Cable Management List

Name	Type	1st wiring (X-axis)	2nd wiring (Y-axis)	3rd wiring (Z-axis)
No cable track (only cable)	N	—	—	—
Cable track S size (inside width 50mm) (Note 1)	CT	N/A	<input type="radio"/>	<input type="radio"/>
Cable track M size (inside width 63mm)	CTM	<input type="radio"/>	<input type="radio"/>	<input type="radio"/>
Cable track L size (inside width 80mm)	CTL	<input type="radio"/>	<input type="radio"/>	<input type="radio"/>
Cable track XL size (inside width 100mm) (Note 2)	CTXL	<input type="radio"/>	N/A	

(Note 1) Only 2nd and 3rd wiring can be selected.

(Note 2) Only 1st wiring can be selected.

Main Specifications

Item	Description
Max. payload	2kg
Positioning repeatability	±0.04mm

Item	Description	
Ambient operation temperature/humidity	0-40°C, less than 85% (non-condensing)	
Degree of protection	—	
Vibration resistance/shock resistance	4.9m/s ²	
Overseas standard	RoHS	
Encoder type	Battery-less absolute	
Number of encoder pulses	XYZ axes	16384pulse/rev
	RBT axes	8192pulse/rev

Specifications of configured axes

The PTP operation enables operations at the maximum speed and maximum acceleration/deceleration.

For CP operations, refer to the reference numbers for maximum speed and acceleration/deceleration on P56.

X-axis

Item	Description	
Axis model number	RCS4-WSA16C-WA-400-20	
Max. speed by accel/ decel and stroke	Accel/decel (G)	0.4
	Stroke (mm)	50-550 600 650 700 750 800 850 900 950 1000 1050 1100
Stroke	Max. speed (mm/s)	1200 1120 990 880 780 715 645 590 535 490 450 415
	Minimum stroke (mm)	50
	Maximum stroke (mm)	1100
	Stroke pitch (mm)	50
Motor type	AC servo motor 400W	

Y-axis

Item	Description	
Axis model number	RCS4-WSA14C-WA-200-16	
Max. speed by accel/ decel and stroke	Accel/decel (G)	0.5
	Stroke (mm)	350~450 500 550 600
	Max. speed (mm/s)	960 920 790 690
Stroke	Minimum stroke (mm)	350
	Maximum stroke (mm)	600
	Stroke pitch (mm)	50
Motor type	AC servo motor 200W	

Z-axis

Item	Description	
Axis model number	RCS4-SA8R-WA-400-10-□-B-W (double slider spec.)	
Speed/ accel/ decel	Accel/decel (G)	0.5
	Max. speed (mm/s)	600
Stroke	Minimum stroke (mm)	100
	Maximum stroke (mm)	200
	Stroke pitch (mm)	50
Motor type	AC servo motor 400W	

R-axis

Item	Description	
Axis model number	RCP6-RTFML-WA-42P-30-360	
Speed/accel/ decel	Accel/decel (G) (Note 6)	0.3
	Max. speed (degree/s)	800
Operation range (degree)	±180	
Maximum torque (N · m) (Note 7)	5.2	
Maximum allowable moment of inertia (kg · m ²) (Note 7)	0.08	
Motor type	Stepper motor 42□size	

(Note 6) 1G≒9807 degrees/s²

(Note 7) Varies depending on speed and accel/decel. See P55 for details.

BT-axis

Item	Description	
Axis configuration	B-axis (wrist bending)	T-axis (wrist turning)
Axis model number	WU-M-WA	
Speed/accel/ decel	Accel/decel (G) (Note 8)	0.3 0.3
	Max. speed (degree/s)	Single operation 900 1200 B&T axes simultaneous ope. 600 600
Operation range (degree)	±105	±360
Motor type	Stepper motor 35□size	
Maximum torque (N · m) (Note 9)	1.65	1.65
Maximum allowable moment of inertia (kg · m ²) (Note 9)	0.015	0.0165

(Note 8) 1G≒9807 degrees/s²

(Note 9) Varies depending on speed and accel/decel. See P55 for details.

(Note) B&T axes are equipped standard with a brake.

Dimensions

*1 The cable track can swell and may become slightly larger than the size in the drawing.
 (Note) The drawing below shows all actuators in the home position.
 (Note) The drawing below shows the combination direction [1] with cable tracks for the 1st, 2nd, and 3rd axis wiring.
 (Note) The screw hole on the bottom surface of the driven axis is for the purpose of packing. Do not use it for installation.

CAD drawings can be downloaded from our website.

www.intelligentactuator.com

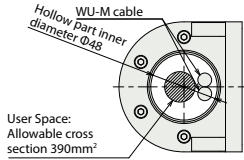
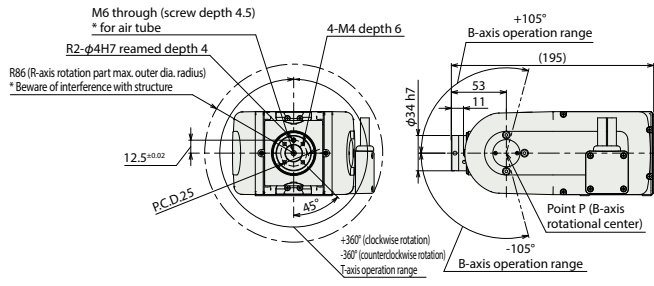
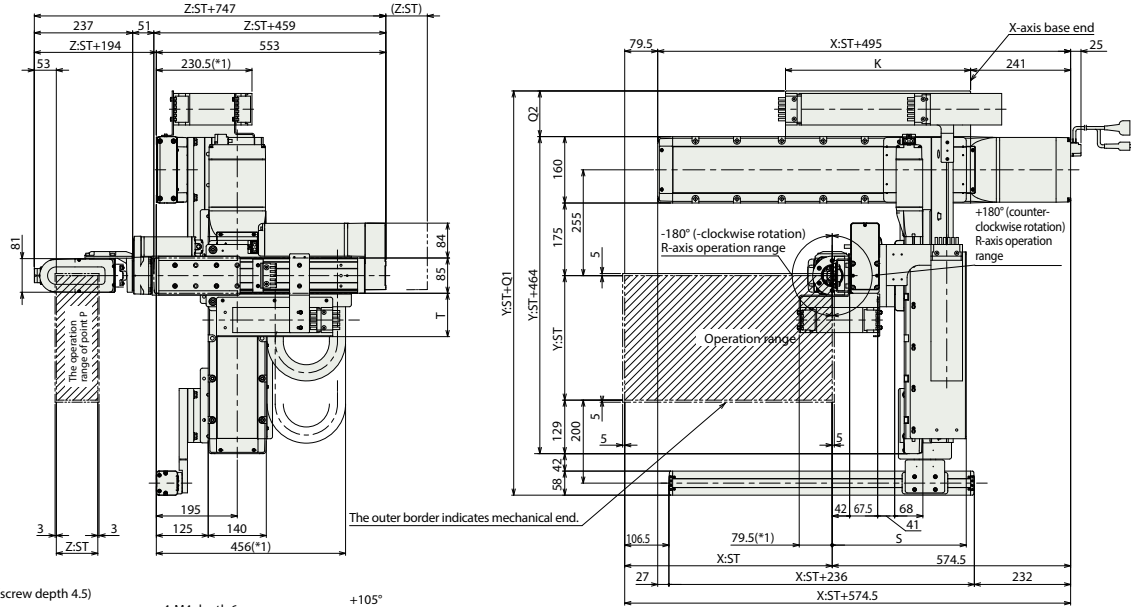

Detail of R-axis hollow part

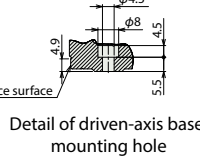
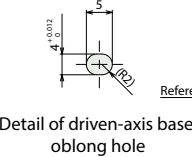
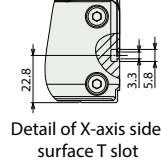
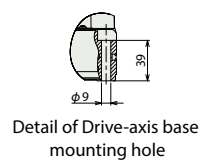
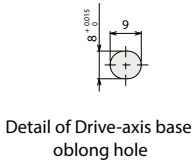

Detail of driven-axis base oblong hole

Detail of driven-axis base mounting hole

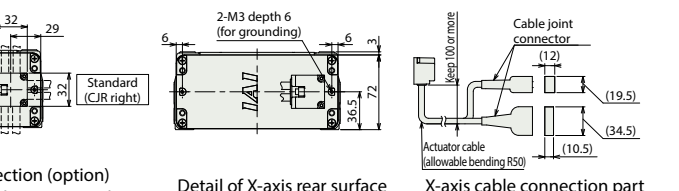
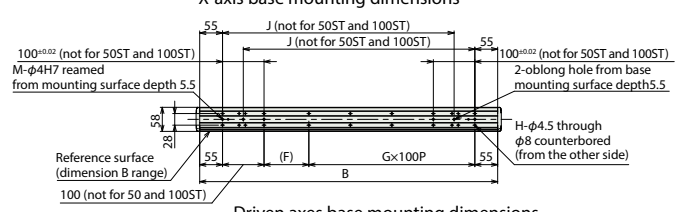
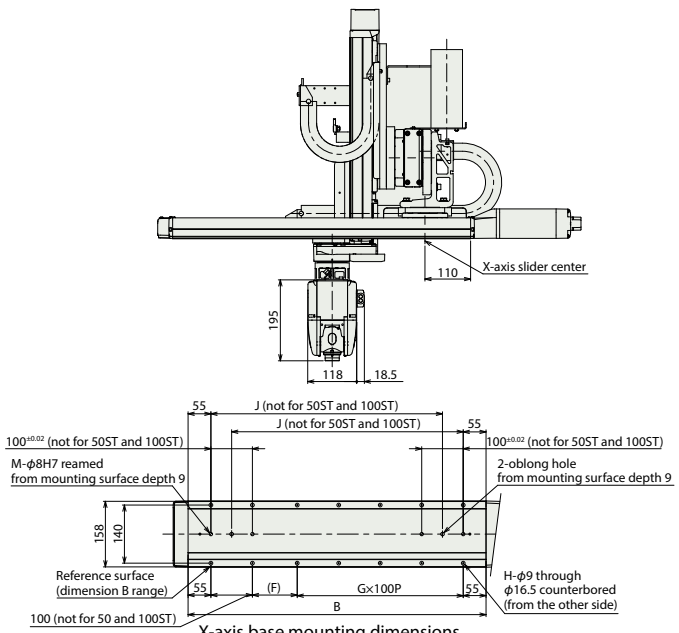

Dimensions by stroke

X-axis stroke	50	100	150	200	250	300	350	400	450	500	550	600	650	700	750	800	850	900	950	1000	1050	1100
B	268	318	368	418	468	518	568	618	668	718	768	818	868	918	968	1018	1068	1118	1168	1218	1268	1318
F	158	208	258	308	358	408	458	508	558	608	658	708	758	808	858	908	958	1008	1058	1108	1158	1208
G	0	0	1	1	2	2	3	3	4	4	5	5	6	6	7	7	8	8	9	9	10	10
H	4	4	8	8	10	10	12	12	14	14	16	16	18	18	20	20	22	22	24	24	26	26
J	—	—	208	258	308	358	408	458	508	558	608	658	708	758	808	858	908	958	1008	1058	1108	1158
K	221	246	271	296	321	346	371	396	421	446	471	496	521	546	571	596	621	646	671	696	721	746
M	2	2	4	4	4	4	4	4	4	4	4	4	4	4	4	4	4	4	4	4	4	4

Cable track size	CT	CTM	CTL	CTXL
Q1	—	674	691	711
Q2	—	110	127	147
S	312	323	340	—
T	104.5	115.5	132.5	—

(Note) Dimensions of Q1, Q2, S and T vary depending on the cable track size.

Cartesian system mass by stroke

X-axis stroke (mm)	50~400	450~800	850~1100
Y-axis stroke (mm)	350~600	56~66	63~73
			71~79

(Note) Refer to the installation manual for how to calculate the mass of the Cartesian system. (unit: kg)

Cable track cross section

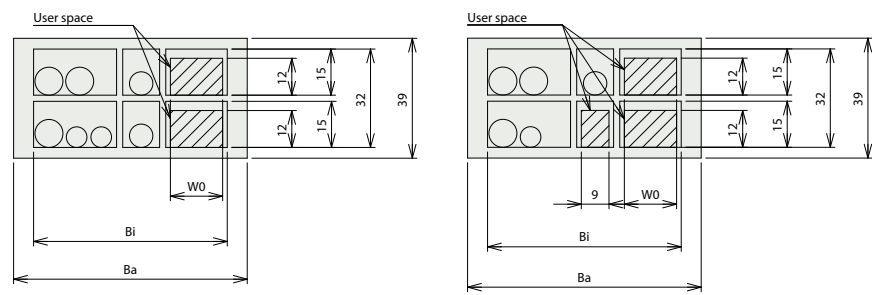

X-Y cable track cross section

Y-Z cable track cross section
Z-R cable track cross section

Cable track size	CT	CTM	CTL	CTXL
Cable track Model number	B17.4.075.0	B17.5.075.0	B17.6.075.0	B17.7.075.0
Ba	60.5	76	93	113
Bi	50	63	80	100
W0	9	17	34	54

Applicable controller

The actuators on this page are operable by the following controller. Select a type suitable for your use.

Name	Ext. appearance	Max. connectable axes	Voltage	Control method													Max. positioning points	Reference page		
				Positioner	Pulse-train	Program	Network *Select													
RSEL-SXGB (for CRS)		8	DC24V single-phase 200VAC three-phase 200VAC	—	—	●	●	●	●	●	—	—	—	●	●	●	—	—	36000	57

(Note) See P58 for the network codes, such as DV and CC.

CRS-XZCY

Battery-less absolute
24V stepper motor

Model specification items

CRS - XZCY1 - WA		B		R1		Cable management			Options					
Series	Type	Configuration direction	Encoder type	1st axis (X-axis)	2nd axis (Z-axis)	3rd axis (Y-axis)	Controller	Cable length	1st wiring	2nd wiring	3rd wiring	4B	SVC	5WCS
		1 See configuration direction	WA Battery-less absolute	Stroke 15 150mm ↓ 80 800mm (every 50mm) Options CJT CJR CJL CJB See options table below	Stroke 5 50mm ↓ 30 300mm (every 50mm) Option B Brake	Stroke 10 100mm ↓ 20 200mm (every 50mm)	R1 RSEL	1L 1m 3L 3m 5L 5m L Lm	See cable management table below			See options table below		

Maximum work envelope	X-axis 800 mm	Z-axis 300 mm	Y-axis 200 mm
Max. payload	1 kg		
Standard cycle time	2.55 seconds		
Positioning repeatability	± 0.06 mm		

The standard cycle time is based on a reciprocating operation at the highest speed on the following condition.

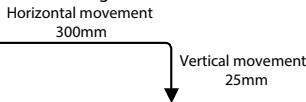

	(1) The cycle time is just a reference value. It may be higher depending on stroke and operating conditions.
	(2) Use RSEL driver modules with the high output setting enabled.
	(3) Positional repeatability conforms to "JIS B 8432 Manipulating industrial robots - Performance criteria and related test methods."

Configuration direction

Direction 1

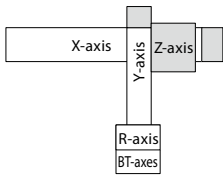

RoHS

(Note) The above picture shows combination direction [1] and all axes with cable track.

Operating directions of the rotation axis (R-axis) / Wrist axes (B-axis and T-axis)

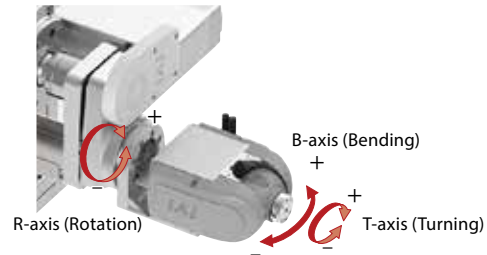

Stroke			
X-axis stroke (mm)	150~350	400~600	650~800
Z-axis stroke (mm)			
50~150	<input type="radio"/>	<input type="radio"/>	<input type="radio"/>
200~300	<input type="radio"/>	<input type="radio"/>	<input type="radio"/>

Cable Length			
Type	Cable code	Length	R1
Standard type	1L	1m	<input type="radio"/>
	3L	3m	<input type="radio"/>
	5L	5m	<input type="radio"/>
	6L ~ 10L	6m ~ 10m	<input type="radio"/>
	11L ~ 15L	11m ~ 15m	<input type="radio"/>

(Note) Standard cables for all the axes.
 (Note) The length of cables for 2nd and 3rd axes is from the cable track exit.
 A robot cable is attached separately for wiring inside the cable track.
 (Note) Standard is 1m, 3m, and 5m. The length can be extended up to 15m in 1m increments.

Cable Management List				
Name	Type	1st wiring (X-axis)	2nd wiring (Z-axis)	3rd wiring (Y-axis)
No cable track (only cable)	N	—	—	—
Cable track S size (inside width 50mm) (Note 1)	CT	N/A	<input type="radio"/>	<input type="radio"/>
Cable track M size (inside width 63mm)	CTM	<input type="radio"/>	<input type="radio"/>	<input type="radio"/>
Cable track L size (inside width 80mm) (Note 2)	CTL	<input type="radio"/>	<input type="radio"/>	N/A
Cable track XL size (inside width 100mm) (Note 3)	CTXL	<input type="radio"/>	N/A	

(Note 1) Only 2nd and 3rd wiring can be selected.
 (Note 2) Only 1st and 2nd wiring can be selected.
 (Note 3) Only 1st wiring can be selected.

Option				
* Please check the Options reference pages to confirm each option.				
Name	Option code	Ref. page		
X-axis	Direction of cable exit (standard)	Not specified	8	<input type="radio"/>
	Direction of cable exit (top)	CJT	8	<input type="radio"/>
	Direction of cable exit (right)	CJR	8	<input type="radio"/>
	Direction of cable exit (left)	CJL	8	<input type="radio"/>
	Direction of cable exit (bottom)	CJB	8	<input type="radio"/>
Z-axis	Brake (Note 4)	B	8	standard
R-axis	Brake	4B	8	<input type="radio"/>
B/T axes	with air joint (Note 5)	5VC	8	<input type="radio"/>
	with wiring collar	5WCS	8	<input type="radio"/>

(Note 4) Z-axis is equipped standard with brake. Make sure to specify it in the Z-axis option column of the model number.
 (Note 5) Applicable tube outer diameter: φ 6mm air joint.

Main Specifications

Item	Description
Max. payload	1kg
Positioning repeatability	±0.06mm

Item	Description
Ambient operation temperature/humidity	0-40°C, less than 85% (non-condensing)
Degree of protection	—
Vibration resistance/shock resistance	4.9m/s ²
Overseas standard	RoHS
Encoder type	Battery-less absolute
Number of encoder pulses	XYZ axes
	RBT axes

Specifications of configured axes

The PTP operation enables operations at the maximum speed and maximum acceleration/deceleration.

For CP operations, refer to the reference numbers for maximum speed and acceleration/deceleration on P56.

X-axis

Item	Description
Axis model number	RCP6-WSA14C-WA-56P-16-□-W (double slider spec.)
Max. speed by accel/decel and stroke	Accel/decel (G)
	Stroke (mm)
	Max. speed (mm/s)
Stroke	Minimum stroke (mm)
	Maximum stroke (mm)
	Stroke pitch (mm)
Motor type	Stepper motor 56□size

Z-axis

Item	Description
Axis model number	RCP6-WSA14R-WA-56P-4-□-B
Speed/accel/decel	Accel/decel (G)
	Max. speed (mm/s)
Stroke	Minimum stroke (mm)
	Maximum stroke (mm)
	Stroke pitch (mm)
Motor type	Stepper motor 56□size

Y-axis

Item	Description
Axis model number	RCP6-WRA14R-WA-56P-16
Speed/accel/decel	Accel/decel (G)
	Max. speed (mm/s)
Stroke	Minimum stroke (mm)
	Maximum stroke (mm)
	Stroke pitch (mm)
Motor type	Stepper motor 56□size

R-axis

Item	Description
Axis model number	RCP6-RTFML-WA-42P-30-360
Speed/accel/decel	Accel/decel (G) (Note 6)
	Max. speed (degree/s)
Operation range (degree)	±180
Maximum torque (N · m) (Note 7)	5.2
Maximum allowable moment of inertia (kg · m ²) (Note 7)	0.08
Motor type	Stepper motor 42□size

(Note 6) 1G ≙ 9807 degrees/s²

(Note 7) Varies depending on speed and accel/decel. See P55 for details.

BT-axis

Item	Description	
Axis configuration	B-axis (wrist bending)	T-axis (wrist turning)
Axis model number	WU-S-WA	
Speed/accel/decel	Accel/decel (G) (Note 8)	0.3
	Max. speed (degree/s)	750
Operation range (degree)	Single operation	0.3
	B&T axes simultaneous ope.	1200
Motor type	600	600
	±100	±360
Maximum torque (N · m) (Note 9)	0.65	0.65
Maximum allowable moment of inertia (kg · m ²) (Note 9)	0.0085	0.0075

(Note 8) 1G ≙ 9807 degrees/s²

(Note 9) Varies depending on speed and accel/decel. See P55 for details.

(Note) B&T axes are equipped standard with a brake.

Dimensions

*1 The cable track can swell and may become slightly larger than the size in the drawing.
 (Note) The drawing below shows all actuators in the home position.
 (Note) The drawing below shows the combination direction [1] with cable tracks for the 1st, 2nd, and 3rd axis wiring.

CAD drawings can be downloaded from our website.
www.intelligentactuator.com

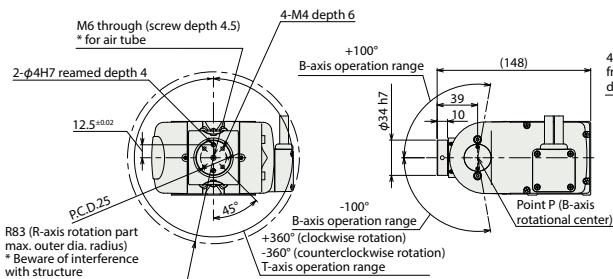
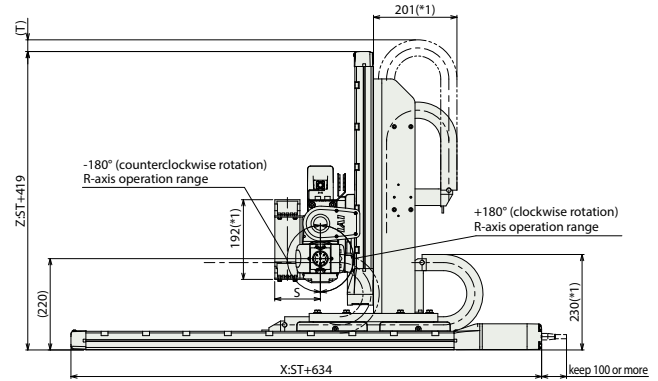
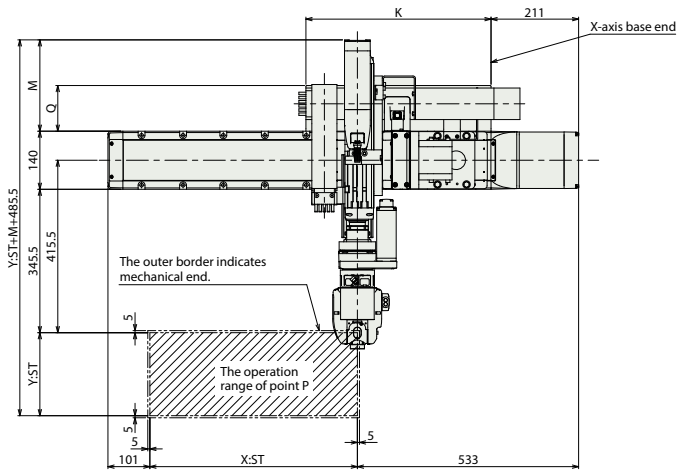
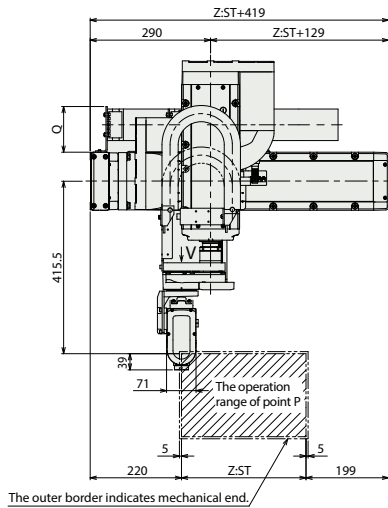

WU-S detail dimensions

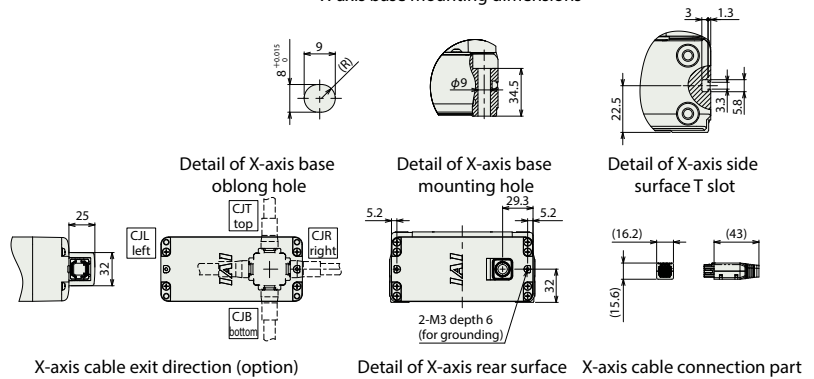
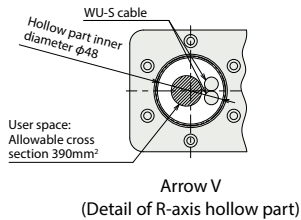

X-axis cable exit direction (option)

Detail of X-axis rear surface

X-axis cable connection part

■ Dimensions by stroke

X-axis stroke	150	200	250	300	350	400	450	500	550	600	650	700	750	800
B	537	587	637	687	737	787	837	887	937	987	1037	1087	1137	1187
F	47	97	47	97	47	97	47	97	47	97	47	97	47	97
G	3	3	4	4	5	5	6	6	7	7	8	8	9	9
H	12	12	14	14	16	16	18	18	20	20	22	22	24	24
J	398	448	498	548	598	648	698	748	798	848	898	948	998	1048
K	271	296	321	346	371	396	421	446	471	496	521	546	571	596

Z-axis stroke	50	100	150	200	250	300
T	155	132	111	88	35	29

Y-axis stroke	100	150	200
M	120	170	220

Cable track size	CT	CTM	CTL	CTXL
Q	-	110	127	147
S	110	121	-	-

(Note) Dimensions of Q and S vary depending on the cable track size.

■ Cartesian system mass by stroke

X-axis stroke (mm)	150~300	350~600	650~800
Z-axis stroke (mm)	50~150	43~49	45~53
	200~300	46~52	49~55

(Note) Refer to the installation manual for how to calculate the mass of the Cartesian system. (unit: kg)

Cable track cross section

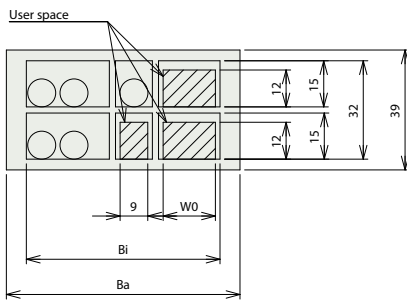

X-Z cable track cross section

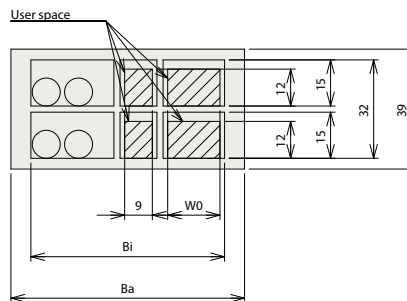

Z-Y cable track cross section

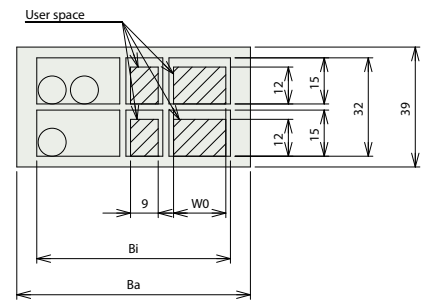

Y-R cable track cross section

Cable track size	CT	CTM	CTL	CTXL
Cable track model number	B17.4.075.0	B17.5.075.0	B17.6.075.0	B17.7.075.0
Ba	60.5	76	93	113
Bi	50	63	80	100
W0	9	17	34	54

Applicable controller

The actuators on this page are operable by the following controller. Select a type suitable for your use.

Name	Ext. appearance	Max. connectable axes	Voltage	Control method													Max. positioning points	Reference page		
				Positioner	Pulse-train	Program	Network *Select													
RSEL-SXZCY (for CRS)		8	DC24V	-	-	●	●	●	●	●	-	-	-	●	●	●	-	-	36000	57

(Note) See P58 for the network codes, such as DV and CC.

CRS-XZCZ

Battery-less absolute
24V stepper motor

Model specification items

CRS		XZCZ1		WA				B		R1									
Series	Type	Configuration direction	Encoder type		1st axis (X-axis)		2nd axis (Z-axis)		3rd axis (Y-axis)	Controller		Cable length		Cable management			Options		
		1 See configuration direction	WA	Battery-less absolute	Stroke	Options	Stroke	Option	Stroke	R1	RSEL	1L	1m	1st wiring	2nd wiring	3rd wiring	4B	See options table below	
					15 ↓ 80 150mm ↓ 800mm (every 50mm)	CJT CJR CJL CJB See options table below	5 ↓ 30 50mm ↓ 300mm (every 50mm)	B Brake	10 ↓ 20 100mm ↓ 200mm (every 50mm)			3L	3m	See cable management table below			SVC		
												5L	5m				SWCS		
												L	Lm						

Maximum work envelope	X-axis 800 mm	Z-axis 300 mm	Y-axis 200 mm
Max. payload	1 kg		
Standard cycle time	2.55 seconds		
Positioning repeatability	± 0.06 mm		

The standard cycle time is based on a reciprocating operation at the highest speed on the following condition.

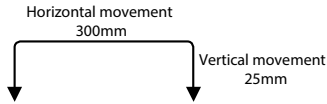

- POINT Selection Notes**
- (1) The cycle time is just a reference value. It may be higher depending on stroke and operating conditions.
 - (2) Use RSEL driver modules with the high output setting enabled.
 - (3) Positional repeatability conforms to "JIS B 8432 Manipulating industrial robots - Performance criteria and related test methods."

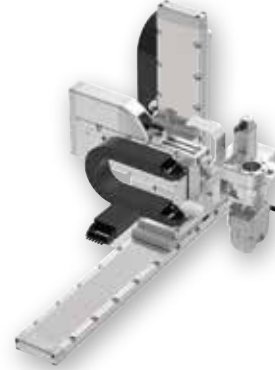

RoHS

(Note) The above picture shows combination direction [1] and all axes with cable track.

Operating directions of the rotation axis (R-axis) / Wrist axes (B-axis and T-axis)

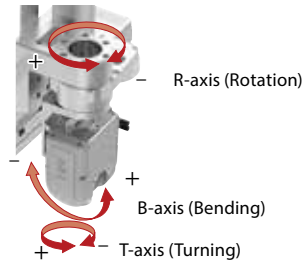

Configuration direction

Direction 1

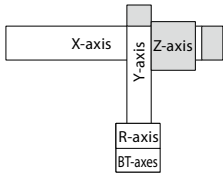

Stroke

X-axis stroke (mm)	150~350	400~600	650~800
Z-axis stroke (mm)			
50~150	○	○	○
200~300	○	○	○

Cable Length

Type	Cable code	Length	R1
Standard type	1L	1m	○
	3L	3m	○
	5L	5m	○
	6L ~ 10L	6m ~ 10m	○
	11L ~ 15L	11m ~ 15m	○

(Note) Standard cables for all the axes.

(Note) The length of cables for 2nd and 3rd axes is from the cable track exit.

A robot cable is attached separately for wiring inside the cable track.

(Note) Standard is 1m, 3m, and 5m. The length can be extended up to 15m in 1m increments.

Cable Management List

Name	Type	1st wiring (X-axis)	2nd wiring (Z-axis)	3rd wiring (Y-axis)
No cable track (only cable)	N	—	—	—
Cable track S size (inside width 50mm) (Note 1)	CT	N/A	○	○
Cable track M size (inside width 63mm)	CTM	○	○	○
Cable track L size (inside width 80mm) (Note 2)	CTL	○	○	N/A
Cable track XL size (inside width 100mm) (Note 3)	CTXL	○	N/A	

(Note 1) Only 2nd and 3rd wiring can be selected.

(Note 2) Only 1st and 2nd wiring can be selected.

(Note 3) Only 1st wiring can be selected.

Option

* Please check the Options reference pages to confirm each option.

Name	Option code	Ref. page	
X-axis	Direction of cable exit (standard)	Not specified	8
	Direction of cable exit (top)	CJT	8
	Direction of cable exit (right)	CJR	8
	Direction of cable exit (left)	CJL	8
	Direction of cable exit (bottom)	CJB	8
Z-axis	Brake (Note 4)	B	8
R-axis	Brake	4B	8
B/T axes	with air joint (Note 5)	5VC	8
	with wiring collar	5WCS	8

(Note 4) Z-axis is equipped standard with brake. Make sure to specify it in the Z-axis option column of the model number.

(Note 5) Applicable tube outer diameter: φ6mm air joint.

Main Specifications

Item	Description
Max. payload	1kg
Positioning repeatability	±0.06mm

Item	Description	
Ambient operation temperature/humidity	0-40°C, less than 85% (non-condensing)	
Degree of protection	—	
Vibration resistance/shock resistance	4.9m/s ²	
Overseas standard	RoHS	
Encoder type	Battery-less absolute	
Number of encoder pulses	XYZ axes	8192pulse/rev
	RBT axes	8192pulse/rev

Specifications of configured axes

The PTP operation enables operations at the maximum speed and maximum acceleration/deceleration.

For CP operations, refer to the reference numbers for maximum speed and acceleration/deceleration on P56.

X-axis

Item	Description		
Axis model number	RCP6-WSA14C-WA-56P-16-□-W (double slider spec.)		
Max. speed by accel/decel and stroke	Accel/decel (G)	0.1	0.2
	Stroke (mm)	150~600	650 700 750 800 150~800
	Max. speed (mm/s)	420	395 360 325 300 280
Stroke	Minimum stroke (mm)	150	
	Maximum stroke (mm)	800	
	Stroke pitch (mm)	50	
Motor type	Stepper motor 56□size		

Z-axis

Item	Description			
Axis model number	RCP6-WSA14R-WA-56P-4-□-B			
Speed/accel/decel	Accel/decel (G)	0.1	0.2	0.3
	Max. speed (mm/s)	85	80	
Stroke	Minimum stroke (mm)	50		
	Maximum stroke (mm)	300		
	Stroke pitch (mm)	50		
Motor type	Stepper motor 56□size			

Y-axis

Item	Description	
Axis model number	RCP6-WRA14R-WA-56P-16	
Speed/accel/decel	Accel/decel (G)	0.3
	Max. speed (mm/s)	560
Stroke	Minimum stroke (mm)	100
	Maximum stroke (mm)	200
	Stroke pitch (mm)	50
Motor type	Stepper motor 56□size	

R-axis

Item	Description	
Axis model number	RCP6-RTFML-WA-42P-30-360	
Speed/accel/decel	Accel/decel (G) (Note 6)	0.3
	Max. speed (degree/s)	800
Operation range (degree)	±180	
Maximum torque (N · m) (Note 7)	5.2	
Maximum allowable moment of inertia (kg · m ²) (Note 7)	0.08	
Motor type	Stepper motor 42□size	

(Note 6) 1G≐9807 degrees/s²

(Note 7) Varies depending on speed and accel/decel. See P55 for details.

BT-axis

Item	Description			
Axis configuration	B-axis (wrist bending)	T-axis (wrist turning)		
Axis model number	WU-S-WA			
Speed/accel/decel	Accel/decel (G) (Note 8)	0.3	0.3	
	Max. speed (degree/s)	Single operation	750	1200
		B&T axes simultaneous op.	600	600
Operation range (degree)	±100	±360		
Motor type	Stepper motor 28□size			
Maximum torque (N · m) (Note 9)	0.65	0.65		
Maximum allowable moment of inertia (kg · m ²) (Note 9)	0.0085	0.0075		

(Note 8) 1G≐9807 degrees/s²

(Note 9) Varies depending on speed and accel/decel. See P55 for details.

(Note) B&T axes are equipped standard with a brake.

Dimensions

*1 The cable track can swell and may become slightly larger than the size in the drawing.
 (Note) The drawing below shows all actuators in the home position.
 (Note) The drawing below shows the combination direction [1] with cable tracks for the 1st, 2nd, and 3rd axis wiring.

CAD drawings can be downloaded from our website.
www.intelligentactuator.com

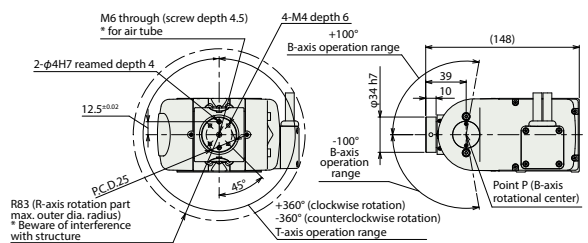
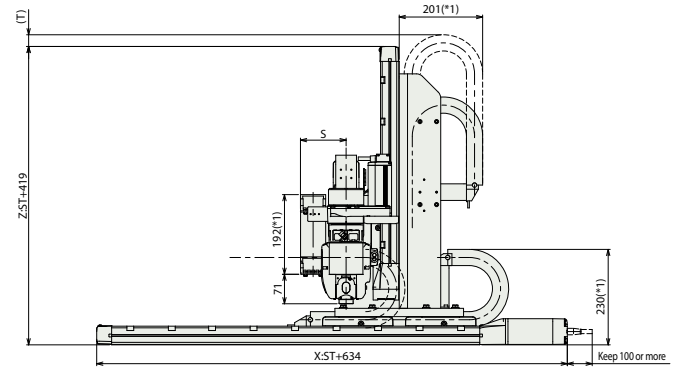
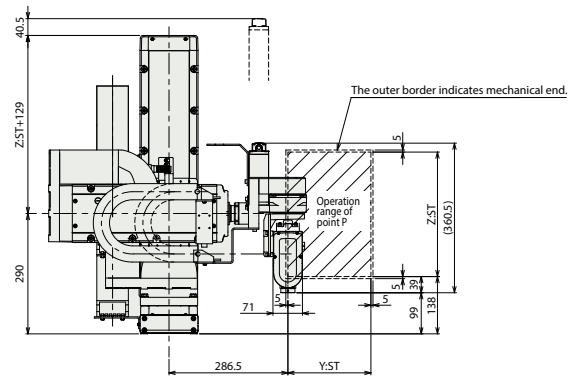
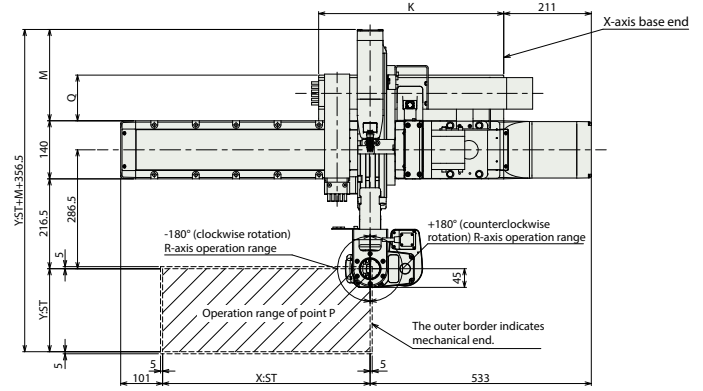

WU-S detail dimensions

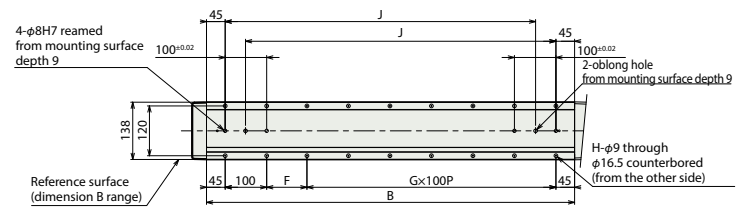

X-axis base mounting dimensions

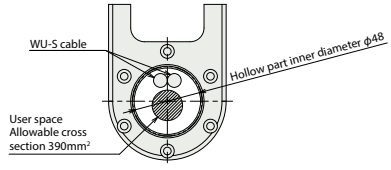

Detail of R-axis hollow part

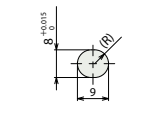

Detail of X-axis base oblong hole

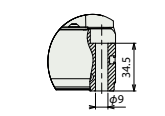

Detail of X-axis base mounting hole

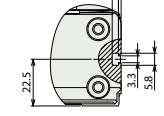

Detail of X-axis side surface T slot

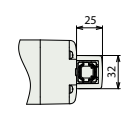

X-axis cable exit direction (option)

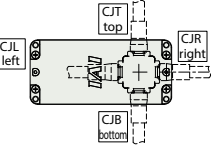

Detail of X-axis rear surface

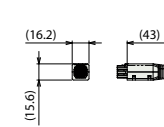

X-axis cable connection part

■ Dimensions by stroke

X-axis stroke	150	200	250	300	350	400	450	500	550	600	650	700	750	800
B	537	587	637	687	737	787	837	887	937	987	1037	1087	1137	1187
F	47	97	47	97	47	97	47	97	47	97	47	97	47	97
G	3	3	4	4	5	5	6	6	7	7	8	8	9	9
H	12	12	14	14	16	16	18	18	20	20	22	22	24	24
J	398	448	498	548	598	648	698	748	798	848	898	948	998	1048
K	271	296	321	346	371	396	421	446	471	496	521	546	571	596

Z-axis stroke	50	100	150	200	250	300
T	155	132	111	88	35	29

Y-axis stroke	100	150	200
M	120	170	220

Cable track size	CT	CTM	CTL	CTXL
Q	—	110	127	147
S	110	121	—	—

(Note) Dimensions of Q and S vary depending on the cable track size.

■ Cartesian system mass by stroke

X-axis stroke (mm)	150~300	350~600	650~800
Z-axis stroke (mm)	50~150	43~53	49~55
200~300	47~53	49~56	53~59

(Note) Refer to the installation manual for how to calculate the mass of the Cartesian system. (unit: kg)

Cable track cross section

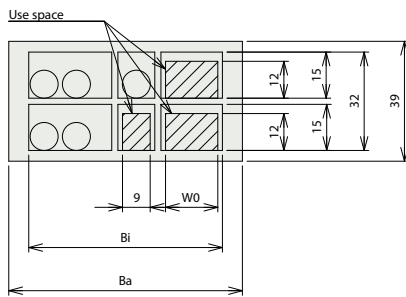

X-Z cable track cross section

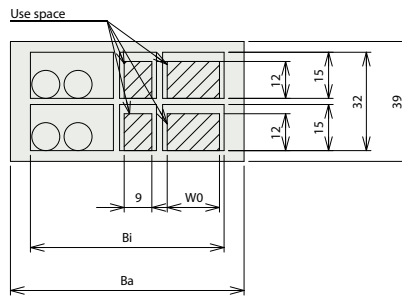

Z-Y cable track cross section

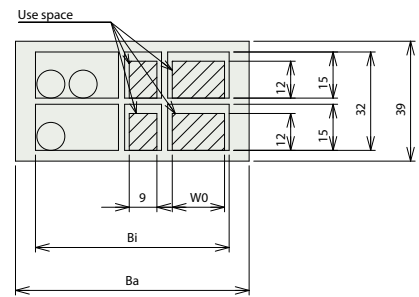

Y-R cable track cross section

Cable track size	CT	CTM	CTL	CTXL
Cable track model number	B17.4.075.0	B17.5.075.0	B17.6.075.0	B17.7.075.0
Ba	60.5	76	93	113
Bi	50	63	80	100
W0	9	17	34	54

Applicable controller

The actuators on this page are operable by the following controller. Select a type suitable for your use.

Name	Ext. appearance	Max. connectable axes	Voltage	Control method														Max. positioning points	Reference page	
				Positioner	Pulse-train	Program	Network *Select													
RSEL-SXZCZ (for CRS)		8	DC24V	—	—	●	●	●	●	●	—	—	—	●	●	●	—	—	36000	57

(Note) See P58 for the network codes, such as DV and CC.

CRS-XZDY

Battery-less absolute
24V stepper motor

Model specification items

Series		Type	Configuration direction	Encoder type		1st axis (X-axis)		2nd axis (Z-axis)		3rd axis (Y-axis)		Controller		Cable length			Cable management			Options	
CRS		XZDY1	1 See configuration direction	WA Battery-less absolute		Stroke 15 150mm ↓ 80 800mm (every 50mm) Options CJT CJR CJL CJB See options table below		Stroke 5 50mm ↓ 30 300mm (every 50mm) Option B Brake		Stroke 25 250mm ↓ 500 500mm (every 50mm)		R1 RSEL		1L 1m 3L 3m 5L 5m L Lm			1st wiring 2nd wiring 3rd wiring See cable management table below			4B 5VC 5WCS See options table below	

Maximum work envelope	X-axis 800 mm	Z-axis 300 mm	Y-axis 500 mm
Max. payload	1 kg		
Standard cycle time	2.28 seconds		
Positioning repeatability	± 0.03 mm		

The standard cycle time is based on a reciprocating operation at the highest speed on the following condition.

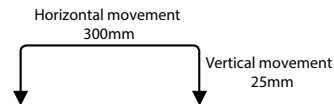

POINT Selection Notes	(1) The cycle time is just a reference value. It may be higher depending on stroke and operating conditions.
	(2) Use RSEL driver modules with the high output setting enabled.
	(3) Positional repeatability conforms to "JIS B 8432 Manipulating industrial robots - Performance criteria and related test methods."



RoHS

(Note) The above picture shows combination direction [1] and all axes with cable track.

Configuration direction

Direction 1

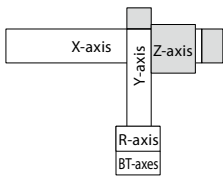

Operating directions of the rotation axis (R-axis) / Wrist axes (B-axis and T-axis)

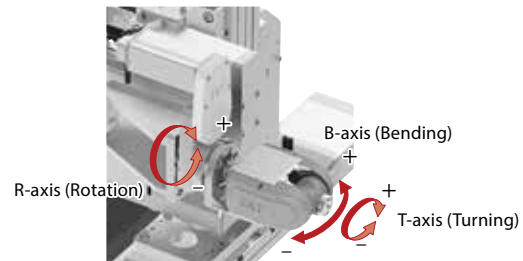

Stroke

X-axis stroke (mm)	150~350	400~600	650~800
Z-axis stroke (mm)			
50~150	<input type="radio"/>	<input type="radio"/>	<input type="radio"/>
200~300	<input type="radio"/>	<input type="radio"/>	<input type="radio"/>

Cable Length

Type	Cable code	Length	R1
Standard type	1L	1m	<input type="radio"/>
	3L	3m	<input type="radio"/>
	5L	5m	<input type="radio"/>
	6L ~ 10L	6m ~ 10m	<input type="radio"/>
	11L ~ 15L	11m ~ 15m	<input type="radio"/>

(Note) Standard cables for all the axes.

(Note) The length of cables for 2nd and 3rd axes is from the cable track exit.

A robot cable is attached separately for wiring inside the cable track.

(Note) Standard is 1m, 3m, and 5m. The length can be extended up to 15m in 1m increments.

Cable Management List

Name	Type	1st wiring (X-axis)	2nd wiring (Z-axis)	3rd wiring (Y-axis)
No cable track (only cable)	N	—	—	—
Cable track S size (inside width 50mm) (Note 1)	CT	N/A	<input type="radio"/>	<input type="radio"/>
Cable track M size (inside width 63mm)	CTM	<input type="radio"/>	<input type="radio"/>	<input type="radio"/>
Cable track L size (inside width 80mm)	CTL	<input type="radio"/>	<input type="radio"/>	<input type="radio"/>
Cable track XL size (inside width 100mm) (Note 2)	CTXL	<input type="radio"/>	N/A	

(Note 1) Only 2nd and 3rd wiring can be selected.

(Note 2) Only 1st wiring can be selected.

Option

* Please check the Options reference pages to confirm each option.

Name	Option code	Ref. page	
X-axis	Direction of cable exit (standard)	Not specified	8 <input type="radio"/>
	Direction of cable exit (top)	CJT	8 <input type="radio"/>
	Direction of cable exit (right)	CJR	8 <input type="radio"/>
	Direction of cable exit (left)	CJL	8 <input type="radio"/>
	Direction of cable exit (bottom)	CJB	8 <input type="radio"/>
Z-axis	Brake (Note 3)	B	8 standard <input type="radio"/>
R-axis	Brake	4B	8 <input type="radio"/>
B/T axes	with air joint (Note 4)	5VC	8 <input type="radio"/>
	with wiring collar	5WCS	8 <input type="radio"/>

(Note 3) Make sure to specify one of codes in the option column of the model number.

(Note 4) Applicable tube outer diameter: φ 6mm air joint.

Main Specifications

Item	Description
Max. payload	1kg
Positioning repeatability	±0.03mm

Item	Description	
Ambient operation temperature/humidity	0-40°C, less than 85% (non-condensing)	
Degree of protection	—	
Vibration resistance/shock resistance	4.9m/s ²	
Overseas standard	RoHS	
Encoder type	Battery-less absolute	
Number of encoder pulses	XYZ axes	8192pulse/rev
	RBT axes	8192pulse/rev

Specifications of configured axes

The PTP operation enables operations at the maximum speed and maximum acceleration/deceleration.
 For CP operations, refer to the reference numbers for maximum speed and acceleration/deceleration on P56.

X-axis

Item	Description																										
Axis model number	RCP6-WSA14C-WA-56P-8-□-W (double slider spec.)																										
Max. speed by accel/decel and stroke	Accel/decel (G)	0.1	0.2	0.3																							
	Stroke (mm)	150-350	400	450	500	550	600	650	700	750	800	150-450	500	550	600	650	700	750	800	150-500	550	600	650	700	750	800	
	Max. speed (mm/s)	370	350	305	270	240	215	195	175	160	145	300	270	240	215	195	175	160	145	250	240	215	195	175	160	145	
Stroke	Minimum stroke (mm)	150																									
	Maximum stroke (mm)	800																									
	Stroke pitch (mm)	50																									
Motor type	Stepper motor 56□size																										

Z-axis

Item	Description		
Axis model number	RCP6-WSA14R-WA-56P-4-□-B-W (double slider spec.)		
Speed/ accel/decel	Accel/decel (G)	0.1	0.2
	Max. speed (mm/s)	105	100
Stroke	Minimum stroke (mm)	50	
	Maximum stroke (mm)	300	
	Stroke pitch (mm)	50	
Motor type	Stepper motor 56□size		

Y-axis

Item	Description	
Axis model number	RCP6-WSA12LR-WA-42P-12 (long slider spec.)	
Speed/ accel/decel	Accel/decel (G)	0.2
	Max. speed (mm/s)	400
Stroke	Minimum stroke (mm)	250
	Maximum stroke (mm)	500
	Stroke pitch (mm)	50
Motor type	Stepper motor 42□size	

R-axis

Item	Description	
Axis model number	RCP6-RTFML-WA-42P-30-360	
Speed/accel/decel	Accel/decel (G) (Note 5)	0.3
	Max. speed (degree/s)	800
Operation range (degree)	±180	
Maximum torque (N · m) (Note 6)	5.2	
Maximum allowable moment of inertia (kg · m ²) (Note 6)	0.08	
Motor type	Stepper motor 42□size	

(Note 6) 1G ≒ 9807 degrees/s²
 (Note 7) Varies depending on speed and accel/decel. See P55 for details.

BT-axis

Item	Description		
Axis configuration	B-axis (wrist bending) T-axis (wrist turning)		
Axis model number	WU-S-WA		
Speed/accel/ decel	Accel/decel (G) (Note 7)	0.3	0.3
	Max. speed (degree/s)	Single operation	750
	B&T axes simultaneous ope.	600	600
Operation range (degree)		±100	±360
Motor type	Stepper motor 28□size		
Maximum torque (N · m) (Note 8)		0.65	0.65
Maximum allowable moment of inertia (kg · m ²) (Note 8)		0.0085	0.0075

(Note 7) 1G ≒ 9807 degrees/s²
 (Note 8) Varies depending on speed and accel/decel. See P55 for details.
 (Note) B&T axes are equipped standard with a brake.

Dimensions

*1 The cable track can swell and may become slightly larger than the size in the drawing.
 (Note) The drawing below shows all actuators in the home position.
 (Note) The drawing below shows the combination direction [1] with cable tracks for the 1st, 2nd, and 3rd axis wiring.

CAD drawings can be downloaded from our website.
www.intelligentactuator.com

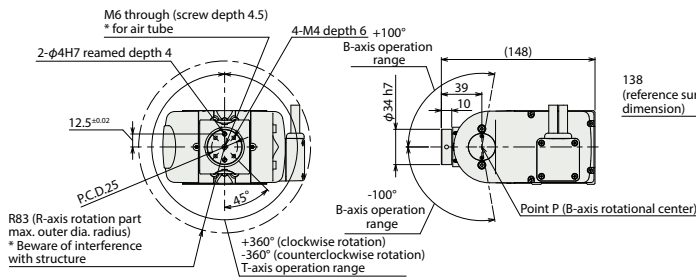
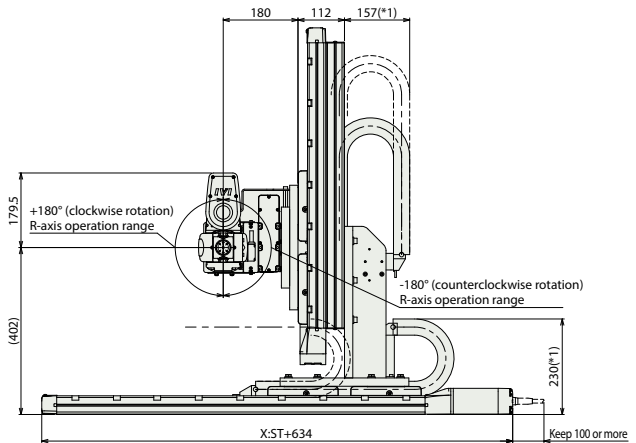
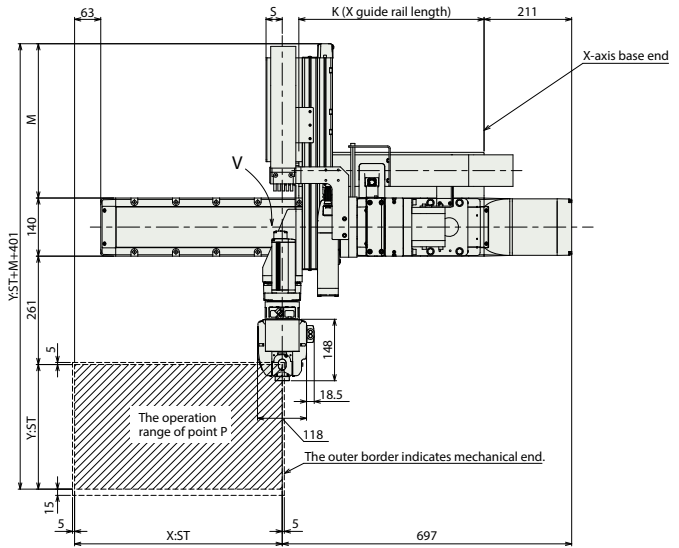
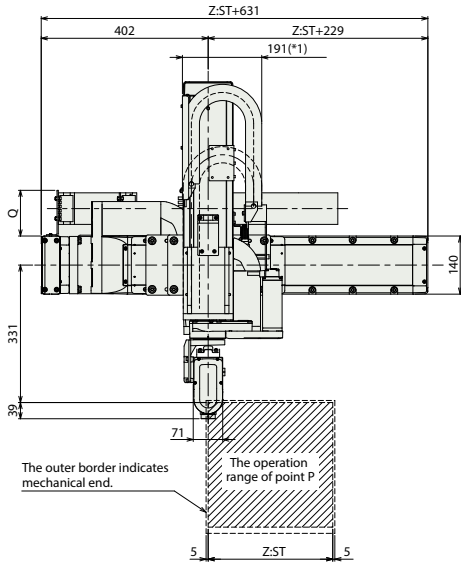

WU-S detail dimensions

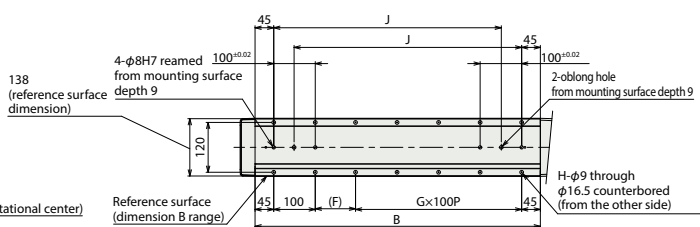
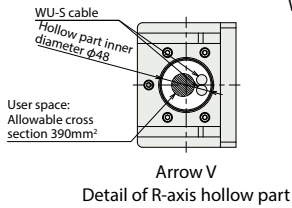

X-axis base mounting dimensions

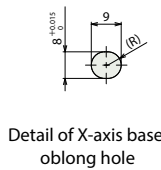

Detail of X-axis base oblong hole

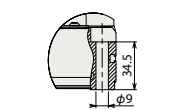

Detail of X-axis base mounting hole

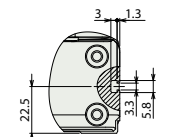

Detail of X-axis side surface T slot

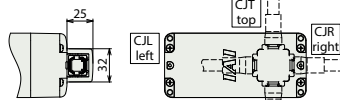

X-axis cable exit direction (option)

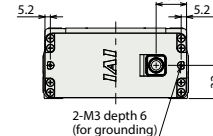

Detail of X-axis rear surface

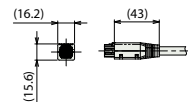

X-axis connection part

Dimensions by stroke

X-axis stroke	150	200	250	300	350	400	450	500	550	600	650	700	750	800
B	537	587	637	687	737	787	837	887	937	987	1037	1087	1137	1187
F	47	97	47	97	47	97	47	97	47	97	47	97	47	97
G	3	3	4	4	5	5	6	6	7	7	8	8	9	9
H	12	12	14	14	16	16	18	18	20	20	22	22	24	24
J	398	448	498	548	598	648	698	748	798	848	898	948	998	1048
K	271	296	321	346	371	396	421	446	471	496	521	546	571	596

Y-axis stroke	250	300	350	400	450	500
M	321.5	371.5	421.5	471.5	521.5	571.5

Cable track size	CT	CTM	CTL	CTXL
Q	-	110	127	147
S	39	50	67	-

(Note) Dimensions of Q and S vary depending on the cable track size.

Cartesian system mass by stroke

X-axis stroke (mm)	150~300	350~600	650~800
Z-axis stroke (mm)	50~150	56~63	60~66
200~300	56~62	59~66	62~68

(Note) Refer to the installation manual for how to calculate the mass of the Cartesian system. (unit: kg)

Cable track cross section

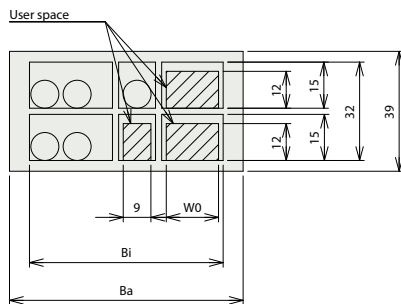

X-Z cable track cross section

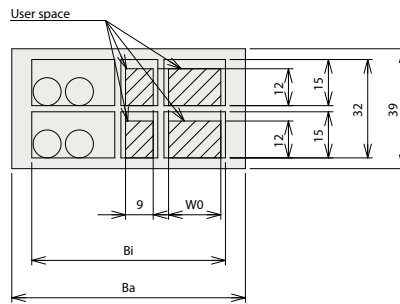

Z-Y cable track cross section
Y-R cable track cross section

Cable track size	CT	CTM	CTL	CTXL
Cable track model number	B17.4.075.0	B17.5.075.0	B17.6.075.0	B17.7.075.0
Ba	60.5	76	93	113
Bi	50	63	80	100
W0	9	17	34	54

Applicable controller

The actuators on this page are operable by the following controller. Select a type suitable for your use.

Name	Ext. appearance	Max. connectable axes	Voltage	Control method														Max. positioning points	Reference page	
				Positioner	Pulse-train	Program	Network *Select													
RSEL-SXZDY (for CRS)		8	DC24V	-	-	●	●	●	●	●	-	-	-	●	●	●	-	-	36000	57

(Note) See P58 for the network codes, such as DV and CC.

CRS-XZDZ

Battery-less absolute
24V stepper motor

Model specification items

Series		Type	Configuration direction	Encoder type		1st axis (X-axis)		2nd axis (Z-axis)		3rd axis (Y-axis)		Controller		Cable length			Cable management			Options	
CRS		XZDZ1	1	WA Battery-less absolute		Stroke 15 ↓ 80 800mm (every 50mm)		Stroke 5 ↓ 30 50mm 300mm (every 50mm)		Stroke 25 ↓ 500 250mm 500mm (every 50mm)		R1 RSEL		1L 1m 3L 3m 5L 5m L m			1st wiring 2nd wiring 3rd wiring See cable management table below			4B 5VC 5WCS See options table below	
			See configuration direction			Options See options table below		Option B Brake													

Maximum work envelope	X-axis 800 mm	Z-axis 300 mm	Y-axis 500 mm
Max. payload	1 kg		
Standard cycle time	2.28 seconds		
Positioning repeatability	± 0.03 mm		

The standard cycle time is based on a reciprocating operation at the highest speed on the following condition.

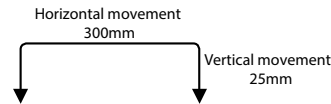

POINT Selection Notes	(1) The cycle time is just a reference value. It may be higher depending on stroke and operating conditions.
	(2) Use RSEL driver modules with the high output setting enabled.
	(3) Positional repeatability conforms to "JIS B 8432 Manipulating industrial robots - Performance criteria and related test methods."



RoHS

(Note) The above picture shows combination direction [1] and all axes with cable track.

Configuration direction

Direction 1

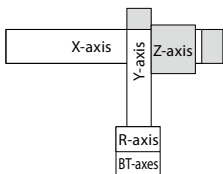

Operating directions of the rotation axis (R-axis) / Wrist axes (B-axis and T-axis)

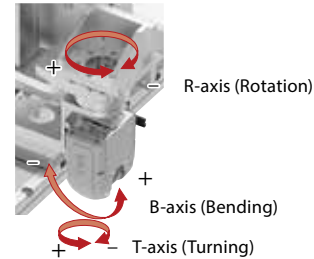

Stroke

X-axis stroke (mm)	150~350	400~600	650~800
Z-axis stroke (mm)			
50~150	○	○	○
200~300	○	○	○

Cable Length

Type	Cable code	Length	R1
Standard type	1L	1m	○
	3L	3m	○
	5L	5m	○
	6L ~ 10L	6m ~ 10m	○
	11L ~ 15L	11m ~ 15m	○

(Note) Standard cables for all the axes.

(Note) The length of cables for 2nd and 3rd axes is from the cable track exit.

A robot cable is attached separately for wiring inside the cable track.

(Note) Standard is 1m, 3m, and 5m. The length can be extended up to 15m in 1m increments.

Option

* Please check the Options reference pages to confirm each option.

Name	Option code	Ref. page	
Direction of cable exit (standard)	Not specified	8	○
Direction of cable exit (top)	CJT	8	○
Direction of cable exit (right)	CJR	8	○
Direction of cable exit (left)	CJL	8	○
Direction of cable exit (bottom)	CJB	8	○
Brake (Note 3)	B	8	standard
R-axis Brake	4B	8	○
with air joint (Note 4)	5VC	8	○
with wiring collar	5WCS	8	○

(Note 3) Make sure to specify one of codes in the option column of the model number.

(Note 4) Applicable tube outer diameter: φ6mm air joint.

Cable Management List

Name	Type	1st wiring (X-axis)	2nd wiring (Z-axis)	3rd wiring (Y-axis)
No cable track (only cable)	N	—	—	—
Cable track S size (inside width 50mm) (Note 1)	CT	N/A	○	○
Cable track M size (inside width 63mm)	CTM	○	○	○
Cable track L size (inside width 80mm)	CTL	○	○	○
Cable track XL size (inside width 100mm) (Note 2)	CTXL	○	N/A	

(Note 1) Only 2nd and 3rd wiring can be selected.

(Note 2) Only 1st wiring can be selected.

Main Specifications

Item	Description
Max. payload	1kg
Positioning repeatability	±0.03mm

Item	Description
Ambient operation temperature/humidity	0-40°C, less than 85% (non-condensing)
Degree of protection	—
Vibration resistance/shock resistance	4.9m/s ²
Overseas standard	RoHS
Encoder type	Battery-less absolute
Number of encoder pulses	XYZ axes
	RBT axes

Specifications of configured axes

The PTP operation enables operations at the maximum speed and maximum acceleration/deceleration. For CP operations, refer to the reference numbers for maximum speed and acceleration/deceleration on P56.

X-axis

Item		Description																								
Axis model number		RCP6-WSA14C-WA-56P-8-□-W (double slider spec.)																								
Max. speed by accel/decel and stroke	Accel/decel (G)	0.1												0.2						0.3						
	Stroke (mm)		150~350	400	450	500	550	600	650	700	750	800	150~450	500	550	600	650	700	750	800	150~500	550	600	650	700	750
Max. speed (mm/s)		370	350	305	270	240	215	195	175	160	145	300	270	240	215	195	175	160	145	250	240	215	195	175	160	145
Stroke	Minimum stroke (mm)	150																								
	Maximum stroke (mm)	800																								
	Stroke pitch (mm)	50																								
Motor type		Stepper motor 56□size																								

Z-axis

Item		Description	
Axis model number		RCP6-WSA14R-WA-56P-4-□-B-W (double slider spec.)	
Speed/ accel/decel	Accel/decel (G)	0.1	0.2
	Max. speed (mm/s)	105	100
Stroke	Minimum stroke (mm)	50	
	Maximum stroke (mm)	300	
	Stroke pitch (mm)	50	
Motor type		Stepper motor 56□size	

Y-axis

Item		Description	
Axis model number		RCP6-WSA12LR-WA-42P-12 (long slider spec.)	
Speed/ accel/decel	Accel/decel (G)	0.2	
	Max. speed (mm/s)	400	
Stroke	Minimum stroke (mm)	250	
	Maximum stroke (mm)	500	
	Stroke pitch (mm)	50	
Motor type		Stepper motor 42□size	

R-axis

Item		Description	
Axis model number		RCP6-RTFML-WA-42P-30-360	
Speed/accel/decel	Accel/decel (G) (Note 5)	0.3	
	Max. speed (degree/s)	800	
Operation range (degree)		±180	
Maximum torque (N · m) (Note 6)		5.2	
Maximum allowable moment of inertia (kg · m ²) (Note 6)		0.08	
Motor type		Stepper motor 42□size	

(Note 6) 1G ≙ 9807 degrees/s²

(Note 7) Varies depending on speed and accel/decel. See P55 for details.

BT-axis

Item		Description	
Axis configuration		B-axis (wrist bending)	T-axis (wrist turning)
Axis model number		WU-S-WA	
Speed/accel/ decel	Accel/decel (G) (Note 7)	0.3	0.3
	Max. speed (degree/s)	Single operation	1200
		B&T axes simultaneous ope.	600
Operation range (degree)		±100	±360
Motor type		Stepper motor 28□size	
Maximum torque (N · m) (Note 8)		0.65	0.65
Maximum allowable moment of inertia (kg · m ²) (Note 8)		0.0085	0.0075

(Note 7) 1G ≙ 9807 degrees/s²

(Note 8) Varies depending on speed and accel/decel. See P55 for details.

(Note) B&T axes are equipped standard with a brake.

Dimensions

*1 The cable track can swell and may become slightly larger than the size in the drawing.
 (Note) The drawing below shows all actuators in the home position.
 (Note) The drawing below shows the combination direction [1] with cable tracks for the 1st, 2nd, and 3rd axis wiring.

CAD drawings can be downloaded from our website.
www.intelligentactuator.com

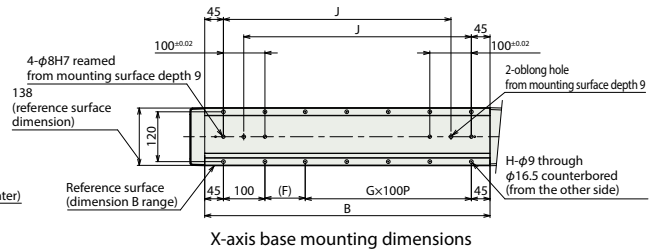
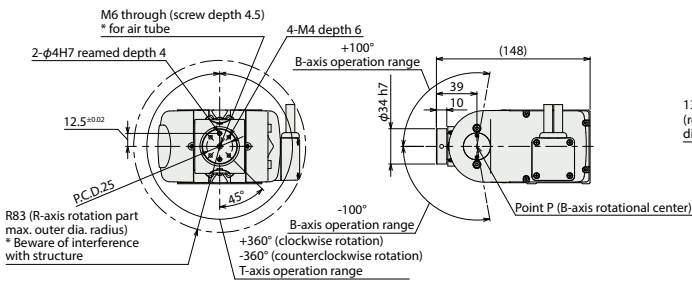
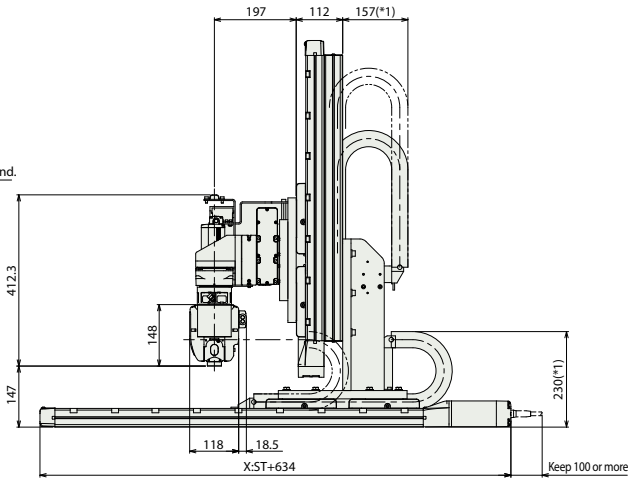
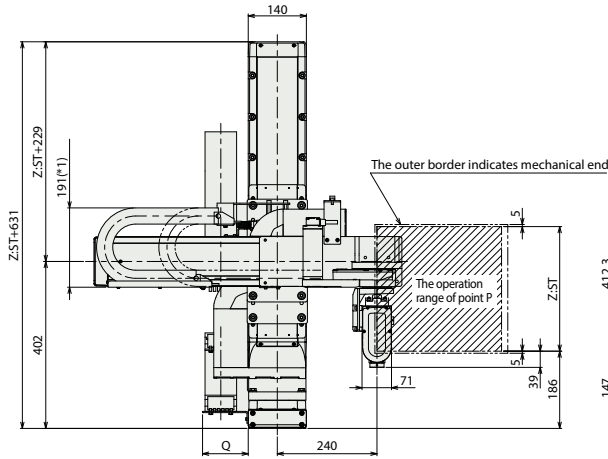
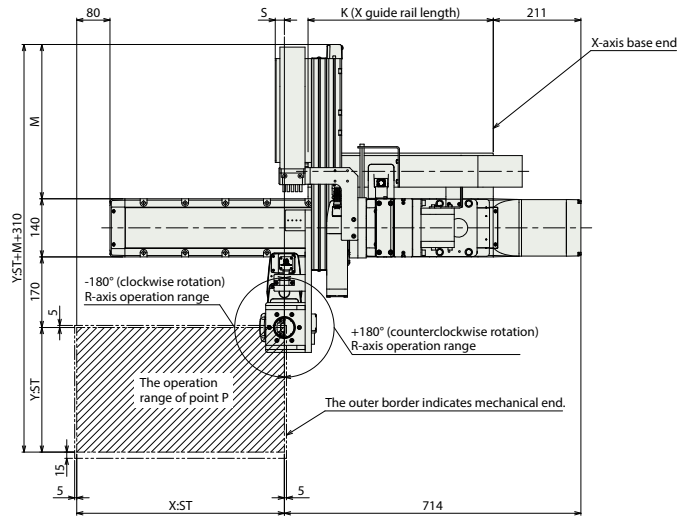

WU-S detail dimensions

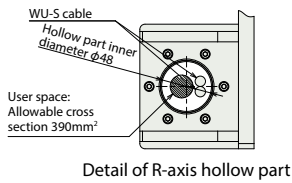

Detail of R-axis hollow part

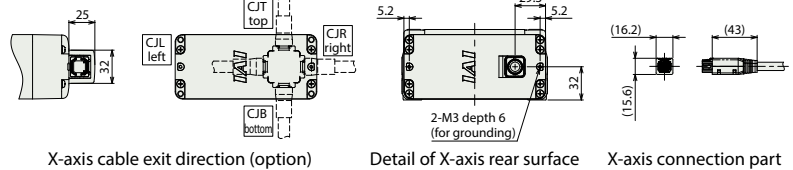
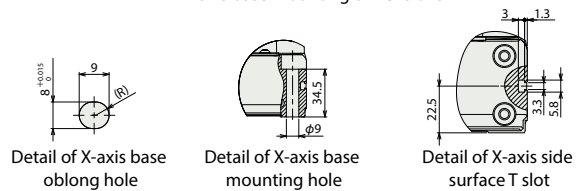

X-axis cable exit direction (option)

Detail of X-axis rear surface

X-axis connection part

■ Dimensions by stroke

X-axis stroke	150	200	250	300	350	400	450	500	550	600	650	700	750	800
B	537	587	637	687	737	787	837	887	937	987	1037	1087	1137	1187
F	47	97	47	97	47	97	47	97	47	97	47	97	47	97
G	3	3	4	4	5	5	6	6	7	7	8	8	9	9
H	12	12	14	14	16	16	18	18	20	20	22	22	24	24
J	398	448	498	548	598	648	698	748	798	848	898	948	998	1048
K	271	296	321	346	371	396	421	446	471	496	521	546	571	596

Y-axis stroke	250	300	350	400	450	500
M	321.5	371.5	421.5	471.5	521.5	571.5

Cable track size	CT	CTM	CTL	CTXL
Q	-	110	127	147
S	22	33	50	-

(Note) Dimensions of Q and S vary depending on the cable track size.

■ Cartesian system mass by stroke

X-axis stroke (mm)	150~300	350~600	650~800
Z-axis stroke (mm)	50~150	57~64	60~66
200~300	57~63	60~67	63~69

(Note) Refer to the installation manual for how to calculate the mass of the Cartesian system. (unit: kg)

Cable track cross section

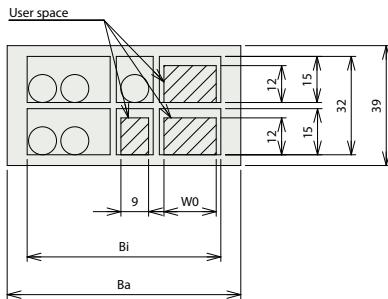

X-Z cable track cross section

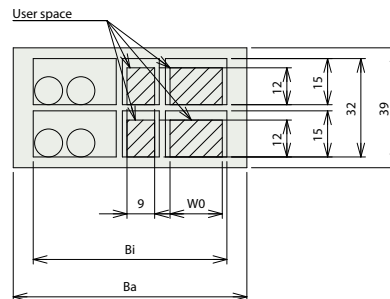

Z-Y cable track cross section
Y-R cable track cross section

Cable track size	CT	CTM	CTL	CTXL
Cable track model number	B17.4.075.0	B17.5.075.0	B17.6.075.0	B17.7.075.0
Ba	60.5	76	93	113
Bi	50	63	80	100
W0	9	17	34	54

Applicable controller

The actuators on this page are operable by the following controller. Select a type suitable for your use.

Name	Ext. appearance	Max. connectable axes	Voltage	Control method														Max. positioning points	Reference page	
				Positioner	Pulse-train	Program	Network *Select													
RSEL-SXZDZ (for CRS)		8	DC24V	—	—	●	●	●	●	●	—	—	—	●	●	●	—	—	36000	57

(Note) See P58 for the network codes, such as DV and CC.

CRS-XZEY

Battery-less absolute
24V stepper motor
200V AC servo motor

Model specification items

CRS - XZEY1 - WA		B		R1										
Series	Type	Configuration direction	Encoder type	1st axis (X-axis)		2nd axis (Z-axis)		3rd axis (Y-axis)		Controller	Cable length	Cable management		Options
		1 See configuration direction	WA Battery-less absolute	Stroke	Options	Stroke	Option	Stroke		R1 RSEL	1L 1m 3L 3m 5L 5m L Lm	1st wiring 2nd wiring 3rd wiring	4B 5VC 5WCS	See options table below
				15 150mm ↓ 80 800mm (every 50mm)	CJT CJR CJL CJB See options table below	5 50mm ↓ 30 300mm (every 50mm)	B Brake	25 250mm ↓ 500 500mm (every 50mm)				See cable management table below		

Maximum work envelope	X-axis 800 mm	Z-axis 300 mm	Y-axis 500 mm
Max. payload	1 kg		
Standard cycle time	1.69 seconds		
Positioning repeatability	± 0.03 mm		

The standard cycle time is based on a reciprocating operation at the highest speed on the following condition.

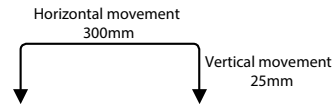

POINT Selection Notes	(1) The cycle time is just a reference value. It may be higher depending on stroke and operating conditions.
	(2) The duty guide value varies depending on operating conditions (payload, acceleration/deceleration, etc.). See P13 for details.
	(3) Use RSEL drive unit of the R-axis and BT axes with the high output setting "Enable".
	(4) Positional repeatability conforms to "JIS B 8432 Manipulating industrial robots - Performance criteria and related test methods."

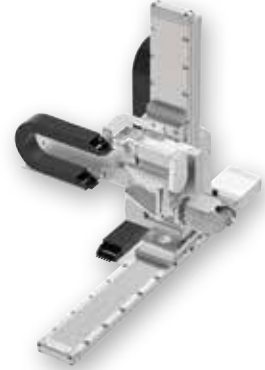

RoHS

(Note) The above picture shows combination direction [1] and all axes with cable track.

Operating directions of the rotation axis (R-axis) / Wrist axes (B-axis and T-axis)

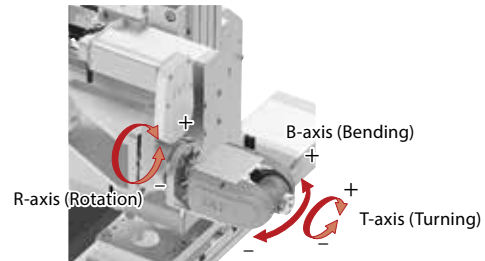

Configuration direction

Direction 1

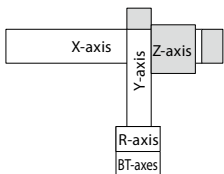

Stroke

X-axis stroke (mm)	150~350	400~600	650~800
Z-axis stroke (mm)			
50~150	<input type="radio"/>	<input type="radio"/>	<input type="radio"/>
200~300	<input type="radio"/>	<input type="radio"/>	<input type="radio"/>

Cable Length

Type	Cable code	Length	R1
Standard type	1L	1m	<input type="radio"/>
	3L	3m	<input type="radio"/>
	5L	5m	<input type="radio"/>
	6L ~ 10L	6m ~ 10m	<input type="radio"/>
	11L ~ 15L	11m ~ 15m	<input type="radio"/>

(Note) Standard cables for all the axes.
(Note) The length of cables for 2nd and 3rd axes is from the cable track exit.
A robot cable is attached separately for wiring inside the cable track.
(Note) Standard is 1m, 3m, and 5m. The length can be extended up to 15m in 1m increments.

Cable Management List

Name	Type	1st wiring (X-axis)	2nd wiring (Z-axis)	3rd wiring (Y-axis)
No cable track (only cable)	N	—	—	—
Cable track S size (inside width 50mm) (Note 1)	CT	N/A	<input type="radio"/>	<input type="radio"/>
Cable track M size (inside width 63mm)	CTM	<input type="radio"/>	<input type="radio"/>	<input type="radio"/>
Cable track L size (inside width 80mm)	CTL	<input type="radio"/>	<input type="radio"/>	<input type="radio"/>
Cable track XL size (inside width 100mm) (Note 2)	CTXL	<input type="radio"/>	N/A	

(Note 1) Only 2nd and 3rd wiring can be selected.
(Note 2) Only 1st wiring can be selected.

Option * Please check the Options reference pages to confirm each option.

Name	Option code	Ref. page	
X-axis	Direction of cable exit (top) (Note 3)	CJT	8 <input type="radio"/>
	Direction of cable exit (right) (Note 3)	CJR	8 <input type="radio"/>
	Direction of cable exit (left) (Note 3)	CJL	8 <input type="radio"/>
	Direction of cable exit (bottom) (Note 3)	CJB	8 <input type="radio"/>
Z-axis	Brake (Note 4)	B	8 standard <input type="radio"/>
R-axis	Brake	4B	8 <input type="radio"/>
B/T axes	with air joint (Note 5)	5VC	8 <input type="radio"/>
	with wiring collar	5WCS	8 <input type="radio"/>

(Note 3) Make sure to specify one of codes at the option column of the model specification item.
(Note 4) Z-axis is equipped standard with brake. Make sure to specify it in the Z-axis option column of the model number.
(Note 5) Applicable tube outer diameter: φ6mm air joint.

Main Specifications

Item	Description
Max. payload	1kg
Positioning repeatability	±0.03mm

Item	Description	
Ambient operation temperature/humidity	0-40°C, less than 85% (non-condensing)	
Degree of protection	—	
Vibration resistance/shock resistance	4.9m/s ²	
Overseas standard	RoHS	
Encoder type	Battery-less absolute	
Number of encoder pulses	XYZ axes	16384pulse/rev
	RBT axes	8192pulse/rev

Specifications of configured axes

The PTP operation enables operations at the maximum speed and maximum acceleration/deceleration.

For CP operations, refer to the reference numbers for maximum speed and acceleration/deceleration on P56.

X-axis

Item	Description	
Axis model number	RCS4-WSA14C-WA-200-8-□-W (double slider spec.)	
Max. speed by accel/decel and stroke	Accel/decel (G) 0.5	
Stroke	Stroke (mm)	150-250 300 350 400 450 500 550 600 650 700 750 800
	Max. speed (mm/s)	480 460 400 350 305 270 240 215 195 175 160 145
Stroke	Minimum stroke (mm)	150
	Maximum stroke (mm)	800
	Stroke pitch (mm)	50
Motor type	AC servo motor 200W	

Z-axis

Item	Description	
Axis model number	RCS4-WSA14R-WA-200-4-□-B-W (double slider spec.)	
Max. speed by accel/decel and stroke	Accel/decel (G) 0.2	
Stroke	Stroke (mm)	50~250 300
	Max. speed (mm/s)	240 230
Stroke	Minimum stroke (mm)	50
	Maximum stroke (mm)	300
	Stroke pitch (mm)	50
Motor type	AC servo motor 200W	

Y-axis

Item	Description	
Axis model number	RCS4-WSA12LR-WA-100-12 (long slider spec.)	
Max. speed by accel/decel and stroke	Accel/decel (G) 0.5	
Stroke	Stroke (mm)	250~400 450 500
	Max. speed (mm/s)	720 610 535
Stroke	Minimum stroke (mm)	250
	Maximum stroke (mm)	500
	Stroke pitch (mm)	50
Motor type	AC servo motor 100W	

R-axis

Item	Description	
Axis model number	RCP6-RTFML-WA-42P-30-360	
Speed/accel/decel	Accel/decel (G) (Note 6)	0.3
	Max. speed (degree/s)	800
Operation range (degree)	±180	
Maximum torque (N · m) (Note 7)	5.2	
Maximum allowable moment of inertia (kg · m ²) (Note 7)	0.08	
Motor type	Stepper motor 42□size	

(Note 6) 1G ≙ 9807 degrees/s²

(Note 7) Varies depending on speed and accel/decel. See P55 for details.

BT-axis

Item	Description	
Axis configuration	B-axis (wrist bending)	T-axis (wrist turning)
Axis model number	WU-S-WA	
Speed/accel/decel	Accel/decel (G) (Note 8)	0.3 0.3
	Max. speed (degree/s)	Single operation 750 1200 B&T axes simultaneous ope. 600 600
Operation range (degree)	±100	±360
Motor type	Stepper motor 28□size	
Maximum torque (N · m) (Note 9)	0.65	0.65
Maximum allowable moment of inertia (kg · m ²) (Note 9)	0.0085	0.0075

(Note 8) 1G ≙ 9807 degrees/s²

(Note 9) Varies depending on speed and accel/decel. See P55 for details.

(Note) B&T axes are equipped standard with a brake.

Dimensions

*1 The cable track can swell and may become slightly larger than the size in the drawing.
 (Note) The drawing below shows all actuators in the home position.
 (Note) The drawing below shows the combination direction [1] with cable tracks for the 1st, 2nd, and 3rd axis wiring.

CAD drawings can be downloaded from our website.
www.intelligentactuator.com

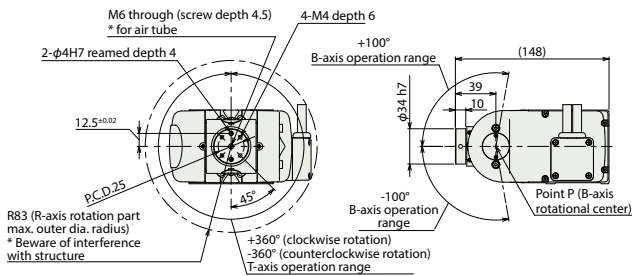
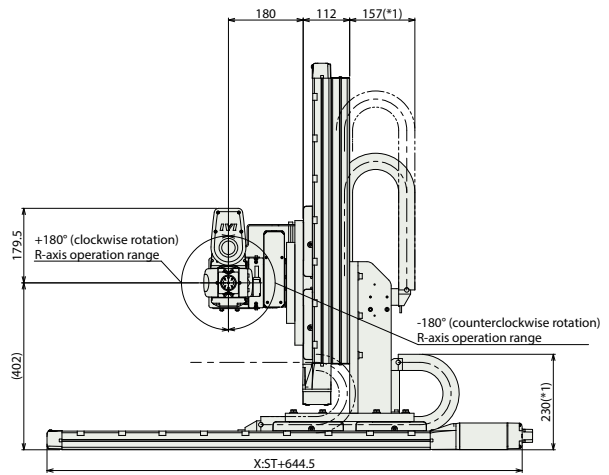
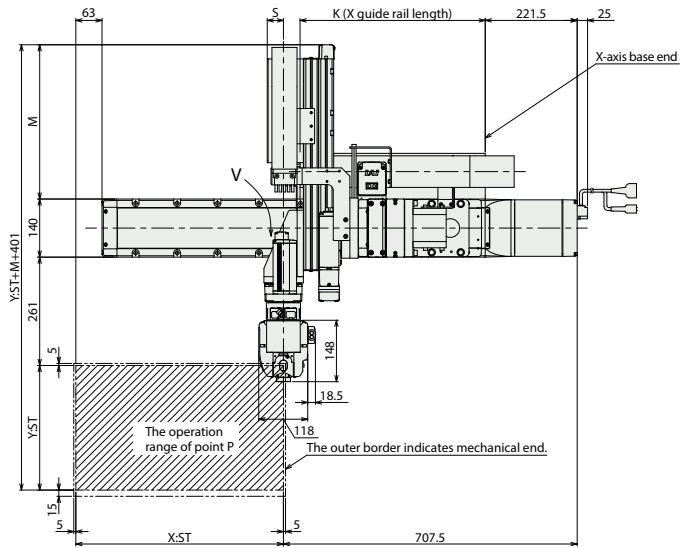
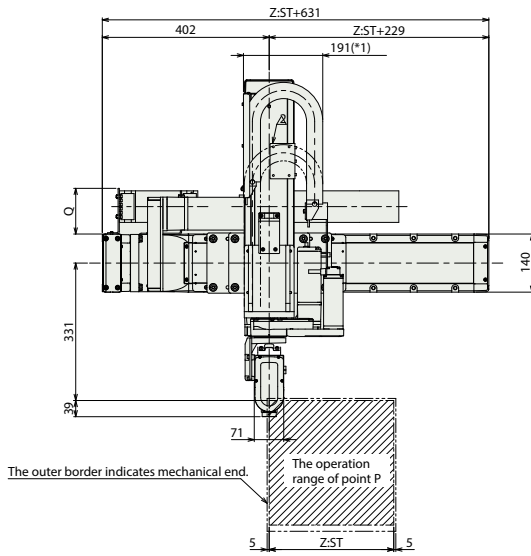

WU-S detail dimensions

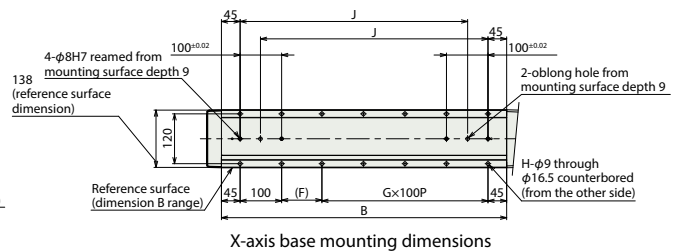

X-axis base mounting dimensions

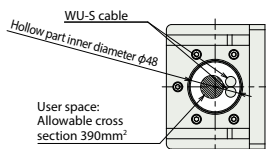

Arrow V
Detail of R-axis hollow part

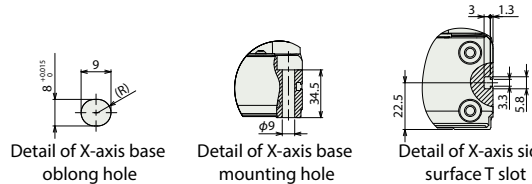

Detail of X-axis base oblong hole Detail of X-axis base mounting hole Detail of X-axis side surface T slot

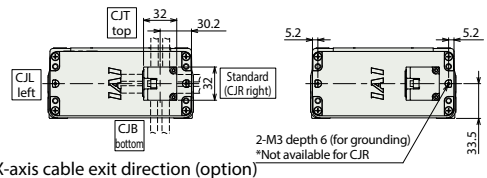

X-axis cable exit direction (option)
 * Standard cable exit direction is right (CJR). Detail of X-axis rear surface

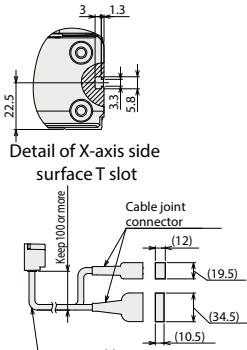

X-axis cable connection part

■ Dimensions by stroke

X-axis stroke	150	200	250	300	350	400	450	500	550	600	650	700	750	800
B	537	587	637	687	737	787	837	887	937	987	1037	1087	1137	1187
F	47	97	47	97	47	97	47	97	47	97	47	97	47	97
G	3	3	4	4	5	5	6	6	7	7	8	8	9	9
H	12	12	14	14	16	16	18	18	20	20	22	22	24	24
J	398	448	498	548	598	648	698	748	798	848	898	948	998	1048
K	271	296	321	346	371	396	421	446	471	496	521	546	571	596

Y-axis stroke	250	300	350	400	450	500
M	321.5	371.5	421.5	471.5	521.5	571.5

Cable track size	CT	CTM	CTL	CTXL
Q	—	110	127	147
S	39	50	67	—

(Note) Dimensions of Q and S vary depending on the cable track size.

■ Cartesian system mass by stroke

X-axis stroke (mm)	150~300	350~600	650~800
Z-axis stroke (mm)			
50~150	54~60	57~64	60~67
200~300	57~63	60~67	63~69

(Note) Refer to the installation manual for how to calculate the mass of the Cartesian system. (unit: kg)

Cable track cross section

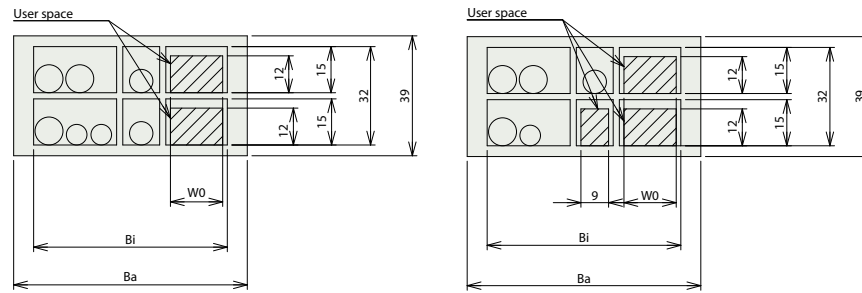

X-Z cable track cross section

Z-Y cable track cross section
Y-R cable track cross section

Cable track size	CT	CTM	CTL	CTXL
Cable track model number	B17.4.075.0	B17.5.075.0	B17.6.075.0	B17.7.075.0
Ba	60.5	76	93	113
Bi	50	63	80	100
W0	9	17	34	54

Applicable controller

The actuators on this page are operable by the following controller. Select a type suitable for your use.

Name	Ext. appearance	Max. connectable axes	Voltage	Control method													Max. positioning points	Reference page	
				Positioner	Pulse-train	Program	Network *Select												
				DV	CC	CIE	PR	CN	ML	ML3	EC	EP	PRT	SSN	ECM				
RSEL-SXZEY (for CRS)		8	DC24V single-phase 200VAC three-phase 200VAC	—	—	●	●	●	●	—	—	—	●	●	●	—	—	36000	57

(Note) See P58 for the network codes, such as DV and CC.

CRS-XZEZ

Battery-less absolute
24V stepper motor
200V AC servo motor

Model specification items

CRS - XZEZ1 - WA		B		R1		Cable management			Options					
Series	Type	Configuration direction	Encoder type	1st axis (X-axis)		2nd axis (Z-axis)		3rd axis (Y-axis)	Controller	Cable length	1st wiring	2nd wiring	3rd wiring	Options
		1 See configuration direction	WA Battery-less absolute	Stroke	Options	Stroke	Option	Stroke	R1 RSEL	1L 1m 3L 3m 5L 5m L Lm	See cable management table below			4B See options table below 5VC 5WCS
				15 150mm ↓ 80 800mm (every 50mm)	CJT CJR CJL CJB See options table below	5 50mm ↓ 30 300mm (every 50mm)	B Brake	25 250mm ↓ 500 500mm (every 50mm)						

Maximum work envelope	X-axis 800 mm	Z-axis 300 mm	Y-axis 500 mm
Max. payload	1 kg		
Standard cycle time	1.69 seconds		
Positioning repeatability	± 0.03 mm		

The standard cycle time is based on a reciprocating operation at the highest speed on the following condition.

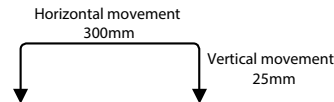

POINT Selection Notes	(1) The cycle time is just a reference value. It may be higher depending on stroke and operating conditions.
	(2) The duty guide value varies depending on operating conditions (payload, acceleration/deceleration, etc.). See P13 for details.
	(3) Use RSEL drive unit of the R-axis and BT axes with the high output setting "Enable."
	(4) Positional repeatability conforms to "JIS B 8432 Manipulating industrial robots - Performance criteria and related test methods."

Configuration direction

Direction 1

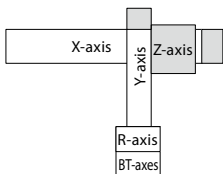

RoHS

(Note) The above picture shows combination direction [1] and all axes with cable track.

Operating directions of the rotation axis (R-axis) / Wrist axes (B-axis and T-axis)

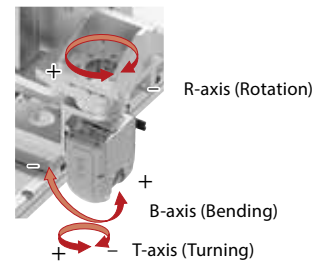

Stroke

X-axis stroke (mm)	150~350	400~600	650~800
Z-axis stroke (mm)			
50~150	<input type="radio"/>	<input type="radio"/>	<input type="radio"/>
200~300	<input type="radio"/>	<input type="radio"/>	<input type="radio"/>

Cable Length

Type	Cable code	Length	R1
Standard type	1L	1m	<input type="radio"/>
	3L	3m	<input type="radio"/>
	5L	5m	<input type="radio"/>
	6L ~ 10L	6m ~ 10m	<input type="radio"/>
	11L ~ 15L	11m ~ 15m	<input type="radio"/>

(Note) Standard cables for all the axes.
 (Note) The length of cables for 2nd and 3rd axes is from the cable track exit.
 A robot cable is attached separately for wiring inside the cable track.
 (Note) Standard is 1m, 3m, and 5m. The length can be extended up to 15m in 1m increments.

Option * Please check the Options reference pages to confirm each option.

	Name	Option code	Ref. page	
X-axis	Direction of cable exit (top) (Note 3)	CJT	8	<input type="radio"/>
	Direction of cable exit (right) (Note 3)	CJR	8	<input type="radio"/>
	Direction of cable exit (left) (Note 3)	CJL	8	<input type="radio"/>
	Direction of cable exit (bottom) (Note 3)	CJB	8	<input type="radio"/>
Z-axis	Brake (Note 4)	B	8	standard
R-axis	Brake	4B	8	<input type="radio"/>
B/T axes	with air joint (Note 5)	5VC	8	<input type="radio"/>
	with wiring collar	5WCS	8	<input type="radio"/>

(Note 3) Make sure to specify one of codes at the option column of the model specification item.
 (Note 4) Z-axis is equipped standard with brake. Make sure to specify it in the Z-axis option column of the model number.
 (Note 5) Applicable tube outer diameter: φ6mm air joint.

Cable Management List

Name	Type	1st wiring (X-axis)	2nd wiring (Z-axis)	3rd wiring (Y-axis)
No cable track (only cable)	N	—	—	—
Cable track S size (inside width 50mm) (Note 1)	CT	N/A	<input type="radio"/>	<input type="radio"/>
Cable track M size (inside width 63mm)	CTM	<input type="radio"/>	<input type="radio"/>	<input type="radio"/>
Cable track L size (inside width 80mm)	CTL	<input type="radio"/>	<input type="radio"/>	<input type="radio"/>
Cable track XL size (inside width 100mm) (Note 2)	CTXL	<input type="radio"/>	N/A	

(Note 1) Only 2nd and 3rd wiring can be selected.
 (Note 2) Only 1st wiring can be selected.

Main Specifications

Item	Description
Max. payload	1kg
Positioning repeatability	±0.03mm

Item	Description	
Ambient operation temperature/humidity	0-40°C, less than 85% (non-condensing)	
Degree of protection	—	
Vibration resistance/shock resistance	4.9m/s ²	
Overseas standard	RoHS	
Encoder type	Battery-less absolute	
Number of encoder pulses	XYZ axes	16384pulse/rev
	RBT axes	8192pulse/rev

Specifications of configured axes

The PTP operation enables operations at the maximum speed and maximum acceleration/deceleration.

For CP operations, refer to the reference numbers for maximum speed and acceleration/deceleration on P56.

X-axis

Item	Description	
Axis model number	RCS4-WSA14C-WA-200-8-□-W (double slider spec.)	
Max. speed by accel/decel and stroke	Accel/decel (G)	0.5
	Stroke (mm)	150-250 300 350 400 450 500 550 600 650 700 750 800
Stroke	Max. speed (mm/s)	480 460 400 350 305 270 240 215 195 175 160 145
	Minimum stroke (mm)	150
	Maximum stroke (mm)	800
	Stroke pitch (mm)	50
Motor type	AC servo motor 200W	

Z-axis

Item	Description	
Axis model number	RCS4-WSA14R-WA-200-4-□-B-W (double slider spec.)	
Max. speed by accel/decel and stroke	Accel/decel (G)	0.2
	Stroke (mm)	50~250 300
	Max. speed (mm/s)	240 230
Stroke	Minimum stroke (mm)	50
	Maximum stroke (mm)	300
	Stroke pitch (mm)	50
Motor type	AC servo motor 200W	

Y-axis

Item	Description	
Axis model number	RCS4-WSA12LR-WA-100-12 (long slider spec.)	
Max. speed by accel/decel and stroke	Accel/decel (G)	0.5
	Stroke (mm)	250~400 450 500
	Max. speed (mm/s)	720 610 535
Stroke	Minimum stroke (mm)	250
	Maximum stroke (mm)	500
	Stroke pitch (mm)	50
Motor type	AC servo motor 100W	

R-axis

Item	Description	
Axis model number	RCP6-RTFML-WA-42P-30-360	
Speed/accel/decel	Accel/decel (G) (Note 6)	0.3
	Max. speed (degree/s)	800
Operation range (degree)	±180	
Maximum torque (N · m) (Note 7)	5.2	
Maximum allowable moment of inertia (kg · m ²) (Note 7)	0.08	
Motor type	Stepper motor 42□size	

(Note 6) 1G ≒ 9807 degrees/s²

(Note 7) Varies depending on speed and accel/decell. See P55 for details.

BT-axis

Item	Description	
Axis configuration	B-axis (wrist bending) T-axis (wrist turning)	
Axis model number	WU-S-WA	
Speed/accel/decel	Accel/decel (G) (Note 8)	0.3 0.3
	Max. speed (degree/s)	Single operation 750 1200 B&T axes simultaneous ope. 600 600
Operation range (degree)	±100 ±360	
Motor type	Stepper motor 28□size	
Maximum torque (N · m) (Note 9)	0.65 0.65	
Maximum allowable moment of inertia (kg · m ²) (Note 9)	0.0085 0.0075	

(Note 8) 1G ≒ 9807 degrees/s²

(Note 9) Varies depending on speed and accel/decel. See P55 for details.

(Note) B&T axes are equipped standard with a brake.

Dimensions

*1 The cable track can swell and may become slightly larger than the size in the drawing.
 (Note) The drawing below shows all actuators in the home position.
 (Note) The drawing below shows the combination direction [1] with cable tracks for the 1st, 2nd, and 3rd axis wiring.

CAD drawings can be downloaded from our website.
www.intelligentactuator.com

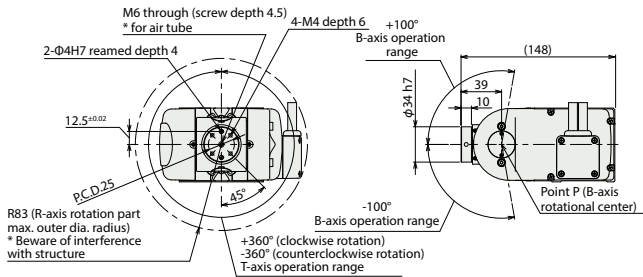
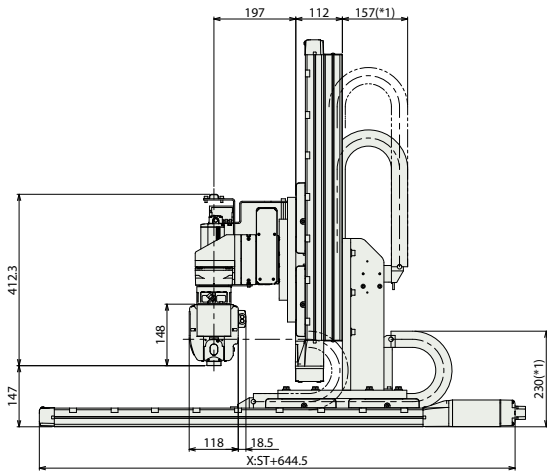
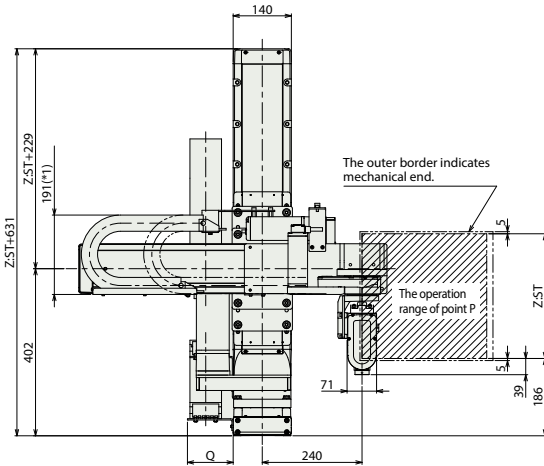
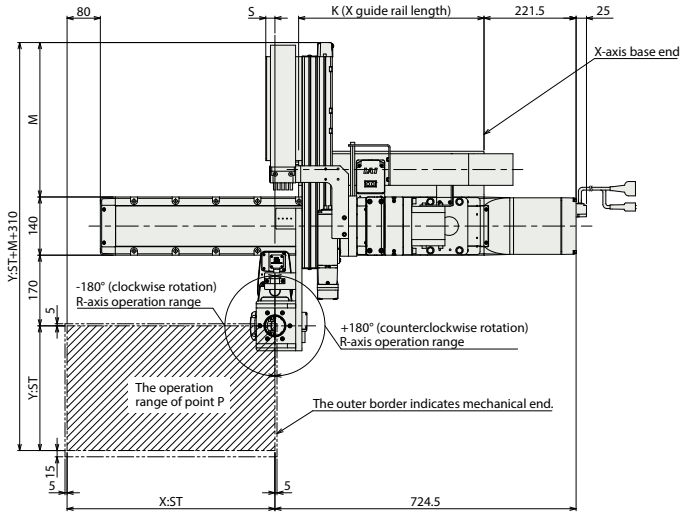

WU-S detail dimensions

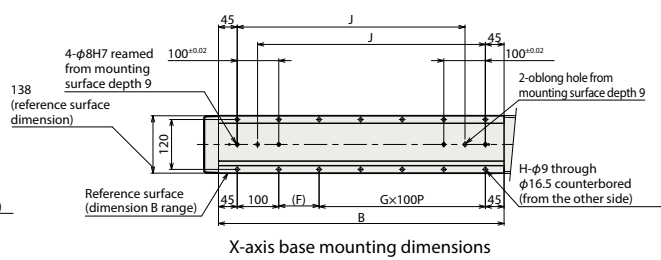

X-axis base mounting dimensions

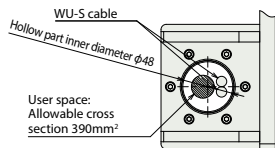

Detail of R-axis hollow part

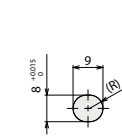

Detail of X-axis base oblong hole

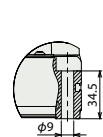

Detail of X-axis base mounting hole

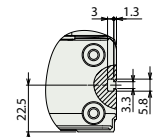

Detail of X-axis side surface T slot

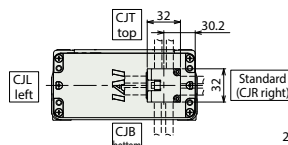

X-axis cable exit direction (option)

* Standard cable exit direction is right (CJR).

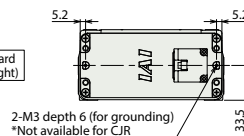

Detail of X-axis rear surface

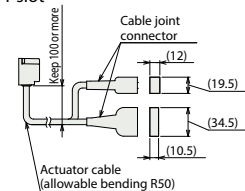

X-axis cable connection part

■ Dimensions by stroke

X-axis stroke	150	200	250	300	350	400	450	500	550	600	650	700	750	800
B	537	587	637	687	737	787	837	887	937	987	1037	1087	1137	1187
F	47	97	47	97	47	97	47	97	47	97	47	97	47	97
G	3	3	4	4	5	5	6	6	7	7	8	8	9	9
H	12	12	14	14	16	16	18	18	20	20	22	22	24	24
J	398	448	498	548	598	648	698	748	798	848	898	948	998	1048
K	271	296	321	346	371	396	421	446	471	496	521	546	571	596

Y-axis stroke	250	300	350	400	450	500
M	321.5	371.5	421.5	471.5	521.5	571.5

Cable track size	CT	CTM	CTL	CTXL
Q	—	110	127	147
S	22	33	50	—

(Note) Dimensions of Q and S vary depending on the cable track size.

■ Cartesian system mass by stroke

Z-axis stroke (mm)	X-axis stroke (mm)		
	150~300	350~600	650~800
50~150	55~59	58~63	61~65
200~300	58~62	60~66	64~68

(Note) Refer to the installation manual for how to calculate the mass of the Cartesian system. (unit: kg)

Cable track cross section

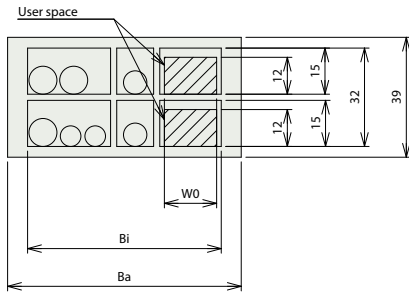

X-Z cable track cross section

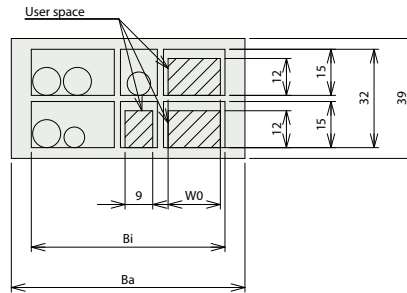

Z-Y cable track cross section
Y-R cable track cross section

Cable track size	CT	CTM	CTL	CTXL
Cable track model number	B17.4.075.0	B17.5.075.0	B17.6.075.0	B17.7.075.0
Ba	60.5	76	93	113
Bi	50	63	80	100
W0	9	17	34	54

Applicable controller

The actuators on this page are operable by the following controller. Select a type suitable for your use.

Name	Ext. appearance	Max. connectable axes	Voltage	Control method													Max. positioning points	Reference page	
				Positioner	Pulse-train	Program	Network *Select												
				DV	CC	CIE	PR	CN	ML	ML3	EC	EP	PRT	SSN	ECM				
RSEL-SXZEZ (for CRS)		8	DC24V single-phase 200VAC three-phase 200VAC	—	—	●	●	●	●	—	—	—	●	●	●	—	—	36000	57

(Note) See P58 for the network codes, such as DV and CC.

Output Torque of R-axis and BT-axes by Speed and Allowable Moment of Inertia by Speed and Acceleration.

R-axis RCP6-RTFML

Output torque by speed

Speed (degree/s)	Output torque
0	5.2
100	5.2
200	4.3
300	3.7
400	3.0
500	2.6
600	2.1
700	1.7
800	1.4

(Unit: N · m)

Allowable moment of inertia by speed and acceleration.

Speed (degree/s)	Accel./decel.	
	0.3G	0.7G
0	0.080	0.054
100	0.080	0.054
200	0.072	0.036
300	0.063	0.032
400	0.059	0.032
500	0.050	0.027
600	0.041	0.018
700	0.018	0.009
800	0.014	0.005

(Unit: kg · m²)

BT axes WU-S

Output torque by speed

Operation at the blank spaces is not possible.

Speed (degree/s)	B-axis	T-axis
0	0.65	0.65
150	0.65	0.65
300	0.62	0.62
450	0.6	0.6
600	0.58	0.58
750	0.52	0.52
900		0.45
1050		0.45
1200		0.45

(Unit: N · m)

Allowable moment of inertia by speed and acceleration.

■ **Without load torque** Operation at the blank spaces is not possible.

Speed (degree/s)	B-axis		T-axis	
	Accel./decel.		0.3G	0.7G
0	0.0085	0.0065	0.0075	0.0035
150	0.0085	0.0065	0.0075	0.0035
300	0.0085	0.005	0.0065	0.0035
450	0.0085	0.005	0.0065	0.0025
600	0.0085	0.005	0.0065	0.0025
750		0.005	0.0065	0.0025
900			0.0065	0.0025
1050			0.0065	0.0025
1200			0.0065	0.0025

(Unit: kg · m²)

■ **With load torque** Operation at the blank spots is not possible.

Speed (degree/s)	B-axis		T-axis
	Accel./decel.		0.3G
0	0.008		0.0035
150	0.008		0.0035
300	0.008		0.0035
450	0.008		0.0035
600	0.008		0.0035
750			0.0035
900			0.0035
1050			0.0035
1200			0.0025

(Unit: kg · m²)

BT axes WU-M

Output torque by speed

Operation at the blank spaces is not possible.

Speed (degree/s)	B-axis	T-axis
0	1.65	1.65
150	1.65	1.65
300	1.65	1.65
450	1.65	1.65
600	1.58	1.58
750	1.36	1.36
900	1.14	1.14
1050		0.96
1200		0.79

(Unit: N · m)

Allowable moment of inertia by speed and acceleration.

■ **Without load torque** Operation at the blank spaces is not possible.

Speed (degree/s)	B-axis		T-axis	
	Accel./decel.		0.3G	0.7G
0	0.015	0.0145	0.0165	0.0126
150	0.015	0.0145	0.0165	0.0126
300	0.015	0.0127	0.0165	0.009
450	0.0099	0.0045	0.0126	0.0063
600	0.009	0.0036	0.0108	0.0054
750		0.0036	0.0099	0.0054
900		0.0036	0.0099	0.0045
1050			0.0081	0.0045
1200			0.0081	0.0045

(Unit: kg · m²)

■ **With load torque** Operations at the blank spaces is not possible.

Speed (degree/s)	B-axis		T-axis
	Accel./decel.		0.3G
0	0.015		0.0126
150	0.015		0.0126
300	0.0118		0.0072
450	0.0055		0.0054
600	0.0055		0.0054
750			0.0054
900			0.0036
1050			0.0036
1200			0.0036

(Unit: kg · m²)

Maximum Speed and Maximum Acceleration/Deceleration

The PTP operation enables operations at the maximum speed and maximum acceleration/deceleration specified in the "specification of the configured axes" of the product page.

For the CP operation, refer to the guide number of maximum speed and acceleration/deceleration shown below.

Guide number of maximum combined speed and maximum acceleration/deceleration of the CP operations.							
	XBA	XGA	XBB	XGB	XZCY XZCZ	XZDY XZDZ	XZEY XZDZ
Maximum combined speed (mm/s)	250	250	700	700	150	150	300
Maximum acceleration/deceleration (G)	0.3	0.3	0.4	0.4	0.2	0.2	0.2

RSEL

Unit-linkage controller



(*1) Conformity with standards depends on models. See P59 for details.

Features

RSEL Controllers that link units required for the CRS Series.

The combination-free RSEL controllers are now joined by unit-linkage controllers that combine units necessary for the Cartesian Type 6-Axis Robot, the CRS Series. See P60 for the detail of unit configuration.

RSEL for CRS
(Cartesian axis stepper motor type)

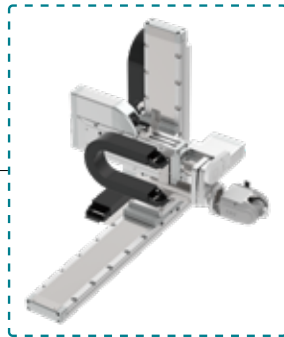

RSEL for CRS
(Cartesian axis AC servo motor type)

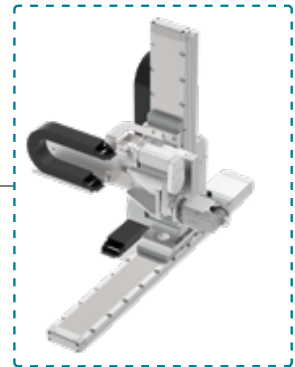

Two axes of driver units can be added

Up to 8 axes can be connected to the RSEL controller.

Two axes of driver units can be added (*) to the 6 axes of the CRS Series.

(*) Purchase driver units separately. See R-unit catalog (CJ0272-1A) for details

(Example)

RSEL **6 axes** for CRS



Up to **2 axes** for driver unit





CRS **6 axes**



Up to **2 axes**



Full line up

Controller type	SXBA	SXGA	SXZCY	SXZCZ	SXZDY	SXZDZ	SXBB	SXGB	SXZEY	SXZEZ
Connected axis (*1)	CRS-XBA	CRS-XGA	CRS-XZCY	CRS-XZCZ	CRS-XZDY	CRS-XZDZ	CRS-XBB	CRS-XGB	CRS-XZEY	CRS-XZEZ
External appearance	 <p>* without additional axes</p>						 <p>* without additional axes</p>			

(*1) Two additional axes can be connected by adding optional driver units.

Model specification items

RSEL - [] - [] - [] - []

Series Type I/O type I/O cable length Option

SXBA	for CRS-XBA
SXBB	for CRS-XBB
SXGA	for CRS-XGA
SXGB	for CRS-XGB
SXZCY	for CRS-XZCY
SXZCZ	for CRS-XZCZ
SXZDY	for CRS-XZDY
SXZDZ	for CRS-XZDZ
SXZEY	for CRS-XZEY
SXZEZ	for CRS-XZEZ

E	Not used
NP	PIO (NPN)
PN	PIO (PNP)
DV	DeviceNet
DV2	DeviceNet (with 2-way connector)
CC	CC-Link
CC2	CC-Link (with 2-way connector)
CIE	CC-Link IE Field
PR	PROFIBUS-DP
EC	EtherCAT
EP	EtherNet/IP
PRT	PROFINET IO

0	Without cable
2	2m (standard)
3	3m
5	5m

(*) When I/O type is other than PIO specification, choose "0 (no cable)."

FN	Fan unit
-----------	----------

(*) When this option is selected, the RSEL-G and RCON-PC come with a fan unit. (RCON-SC is equipped standard with a fan unit.)

The operating temperature of the SEL unit and Driver unit is 0 - 55°C .
 However, a fan unit is needed for the SEL unit when operating at 40°C or higher.
 The driver unit has temperature derating if the fan unit is not used.
 Operations without a fan unit at 0 - 40°C are possible without derating. However, when operating at 0 - 55°C , the operation duty ratio should be lowered by 20% for every 5°C .

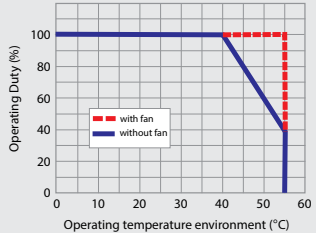

Basic specifications

Item		Specification							
Input power voltage		24VDC ±10% 200VAC - 230VAC±10% (200V power unit)							
Input power current		Depends on system configuration							
Number of controlled axes		1 to 8 axes							
Compatible encoder	24V system	Incremental (including ABZ parallel) Battery-less absolute							
	200V system	Incremental (including ABZ parallel), Battery-less absolute, Quasi absolute, Index absolute, (SCON connection spec.) absolute, Multi-rotation absolute.							
Compatible field network		CC-Link, CCinkIE Field, DeviceNet, EtherCAT, EtherNet/IP, PROFIBUS-DP, PROFINET IO							
Configured unit		SEL unit, Driver unit, Expansion unit, Power unit, Fan unit, Terminal unit, Simple absolute unit							
Serial communication function	Teaching port	Communication system	RS232C						
		Communication speed	Max. 115.2kbps						
	USB port	Communication system	USB						
		Communication speed	12Mbps full speed						
		Ethernet (RJ-45), PSA-24 communication							
Emergency stop/ Enable operation		Collective system control by stop signal of SEL unit							
Data storage device		FlashROM + involatile RAM (FRAM) * battery not needed							
Safety category		B (up to 4 by external circuit)							
Safety circuit		Duplex circuit possible							
Emergency stop input		B-contact input (possible to select from external power supply, duplex circuit or internal power supply)							
Enable input		B-contact input (possible to select from external power supply, duplex circuit or internal power supply)							
Speed setting		1 mm/s and up. Upper limit depends on actuator spec.							
Acceleration/deceleration setting		0.01G and up. Upper limit depends on actuator spec.							
Number of axis groups		2 (up to 8 axes per group)							
Programing language		Super SEL language							
Number of programs		512 (99 input signals in BCD and 255 input signals in binary)							
Number of program steps		20,000 steps							
Multi-task program		16 programs							
Number of positions		36,000 positions (varies depending on the number of axis groups)							
Data input method	Teaching port	Touch panel teaching pendant, PC-dedicated teaching software							
	USB	PC-dedicated teaching software							
	Ethernet								
Standard input/output		(I/O slot selection) input 16 / output 16							
Extended input/output		PIO units can be connected up to 8 units.							
Ethernet		10/100BASE-T (RJ-45 connector)							
		XSEL serial communication protocol (format B) *1							
USB		USB2.0 (Mini-B), XSEL serial communication protocol (format B) *1							
Clock function	Retaining time	Approx. 10 days							
	Recharging time	Approx. 100 hours							
SD card		SD/SDHC (only update function is used)							
Protection function		Over current, abnormal temperature, encoder disconnection, over load							
Preventative & predictive maintenance functions		Low electrolytic condenser capacity, low fan revolution							
Ambient operation temperature		(without fan) 0-40°C , (with fan) 0-55°C *0-40°C for simple absolute unit							
Operation humidity		less than 85%RH (non-condensing)							
Operation atmosphere		Not exposed to corrosive gas, nor dusts							
Vibration resistance		Frequency 10-57Hz/amplitude: 0.075mm, Frequency 57-150Hz/acceleration 9.8m/s ² , XYZ directions Sweepage time: 10 minutes Number of sweepages: 10 times							
Impact resistance		Drop height 800mm, 1 corner, 3 edges, 6 surfaces							
Electric shock protection mechanism	24V	Class III							
	200V	Class I							
Degree of protection		IP20							
Dielectric strength voltage		500VDC, 10MΩ							
Cooling method		Natural cooling, (optional) forced cooling by fan unit							
Connection between each units		Unit-linkage method							
Mounting method		Installed by DIN rail (35mm)							
Regulations and Standards	Unit name	SEL unit	24V driver unit	200V driver unit	200V power unit	Simple absolute unit	SCON extension unit	PIO/SIO/SCON extension unit	PIO unit
	CE marking	○	○	— (To be acquired)	— (To be acquired)	○	○	○	○
	UL	○	○	— (To be acquired)	— (To be acquired)	○	○	○	○

*1 Only one port is available for communication of XSEL serial communication protocol (format B).
Priority for communication is the teaching port (highest priority), USB and Ethernet (lowest priority).
Lower priority does not respond.

Unit Configuration and External Dimensions

RSEL-SXBA
RSEL-SXGA

24V driver unit
RCON-PC-2, 3 units

SEL unit
RSEL-G

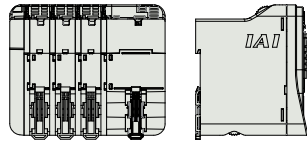
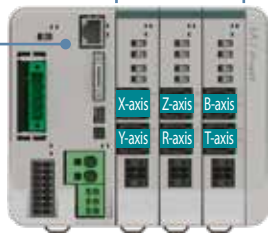

RSEL-SXZCY
RSEL-SXZCZ
RSEL-SXZDY
RSEL-SXZDZ

24V driver unit
RCON-PC-2, 3 units

SEL unit
RSEL-G

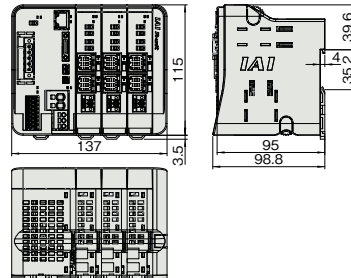
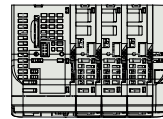
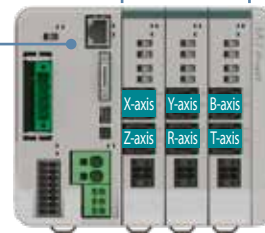

CAD drawings can be downloaded from our website.
www.intelligentactuator.com



RSEL-SXBB
RSEL-SXGB

24V driver unit
RCON-PC-1, 1 unit
RCON-PC-2, 1 unit

200V power unit
RCON-PS2-3, 1 unit

200V driver unit
RCON-SC-1, 1 unit

SEL unit
RSEL-G

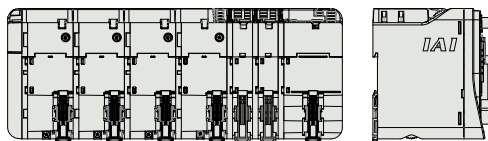
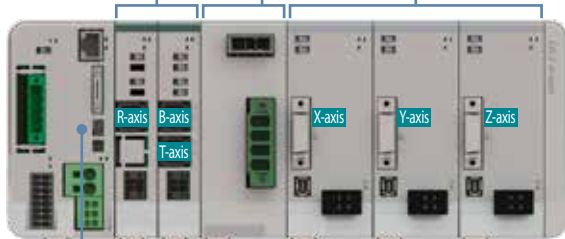

RSEL-SXZEY
RSEL-SXZEZ

24V driver unit
RCON-PC-1, 1 unit
RCON-PC-2, 1 unit

200V power unit
RCON-PS2-3, 1 unit

200V driver unit
RCON-SC-1, 1 unit

SEL unit
RSEL-G

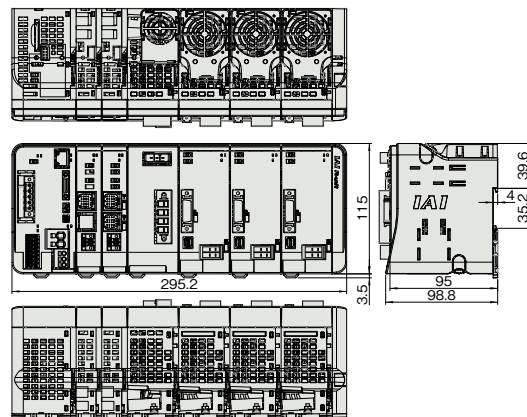

System configuration

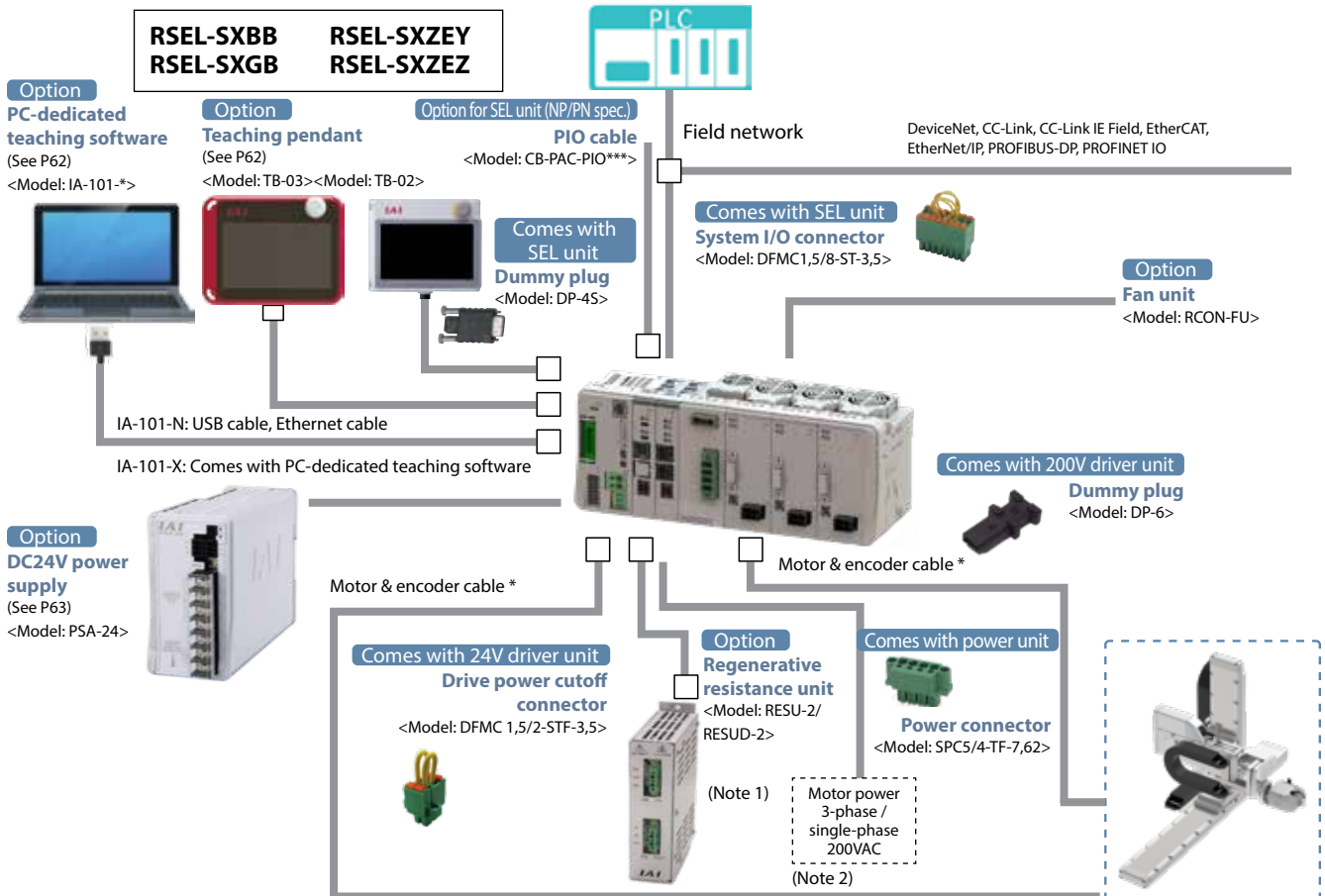
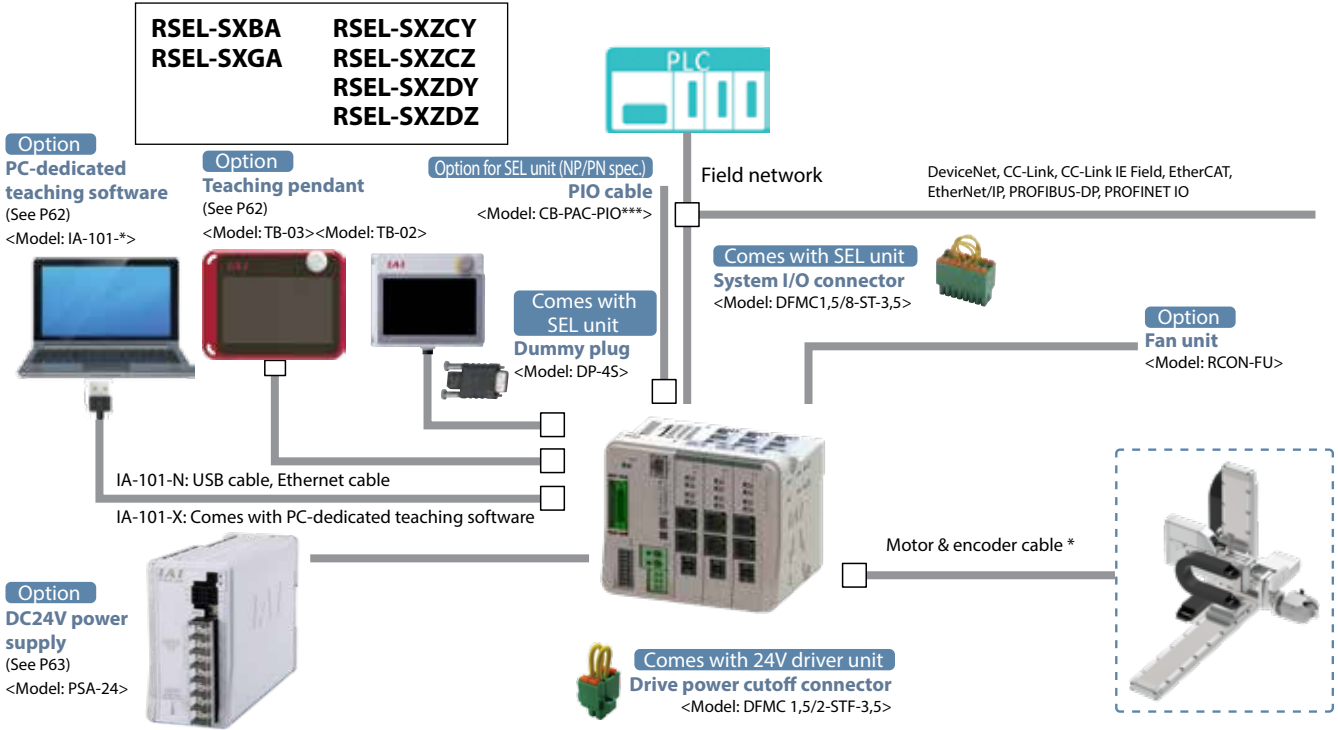

Note 1: The RCON-SC and RCON-PS2 are equipped with a 60W regenerative resistance unit respectively. Basically, a regenerative resistance unit is not needed, but if it is not enough, use external resistance unit(s).

Note 2: RCON-PS2 is equipped with an internal nose filter. Install another nose filter in order to comply with CE marking or equivalent. The recommendable noise filter: for 3-phase: TAC-20-683 (manufacturer COSEL) for single-phase: NBH-20-432 (manufacturer COSEL)

* Motor & encoder cable comes with the actuator. The cable varies depending on the actuator type to be used. When ordering a replacement cable, see P65.

Option

Touch panel teaching pendant

Feature A teaching device for position inputs, trial runs and monitoring, etc.

Model **TB-03-** See IAI website for supported versions.

Configuration

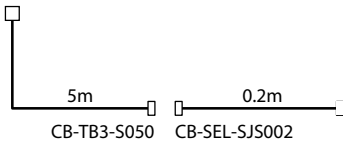

External dimensions

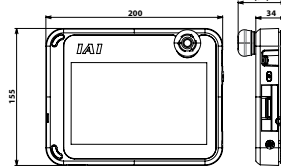

Specifications

Rated voltage	24VDC
Power consumption	3.6W or less (150mA or less)
Ambient operation temp.	0-40°C
Ambient operation humidity	20-85%RH (non-condensing)
Degree of protection	IPX0
Mass	670g (TB-03 unit only)
Recharging method	Dedicated AC adaptor/ Wired connection with controller

Model **TB-02(D)-** See IAI website for supported versions.

Configuration

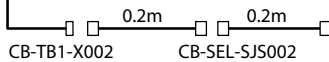

External dimensions

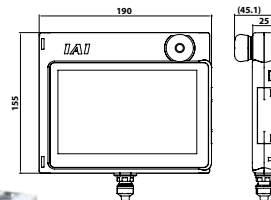

Specifications

Rated voltage	24VDC
Power consumption	3.6W or less (150mA or less)
Ambient operation temp.	0-40°C
Ambient operation humidity	20-85%RH (non-condensing)
Degree of protection	IP20
Mass	470g (TB-02 unit only)

PC-dedicated teaching software (Windows only)

for RSEL

Model **XSEL PC Software**

Features PC teaching software (DVD) only.
If you want to connect both the controller and PC side with a USB cable or Ethernet cable, only the software needs to be purchased. A cable that meet the following specifications is to be prepared by the customer.

Configuration See IAI website for supported versions.

	Controller side connector	Max. cable length
USB cable specification	USB Mini-B	5m
Ethernet cable specification*	10/100/1000BASE-T (RJ-45)	100m

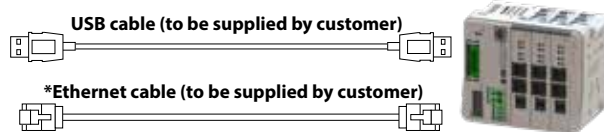

* In order to use EtherNet cable, parameters need to be set by other cables of IA-101-X-MW-JS or USB mini-B.

Warning

Make sure to connect a stop switch on the system I/O connector when operating an actuator with USB connection.
If an emergency switch is not used, use "IA-101-X-USBMW" that has an emergency stop switch.

Supported Windows: 8.1/10



or PC Software downloaded link

Supported Windows: 8.1/10



Model **IA-101-X-MW-JS** (with RS232C cable + connector conversion cable)

Configuration

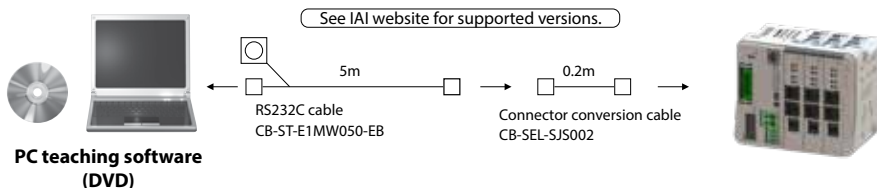

The CB-ST-E1MW050-EB cannot be used when "building an enable system that uses system I/O connector with external power supply" or when "building a duplex safety circuit."

24V power supply

Description Recommended power supply for the RSEL controller. It can easily be installed thanks to the same height as that of the RSEL controller. It can also be connected to the RSEL controller to monitor the condition of power supply.

Model **PSA-24 (without fan)**

Model **PSA-24L (with fan)**



Specifications

Item	Specification	
	100VAC	200VAC
Input power voltage	100VAC-230VAC ±10%	
Input current	3.9A or less	1.9A or less
Power capacity	without fan: 250VA with fan: 390VA	without fan: 280VA with fan: 380VA
Inrush current ^{*1}	without fan: 17A (typ) with fan: 27.4A (typ)	without fan: 34A (typ) with fan: 54.8A (typ)
Heat quantity	28.6W	20.4W
Output voltage ^{*2}	24V±10%	
Continuous rated output	without fan: 8.5A (204W)	with fan: 13.8A (330W)
Peak output	17A (408W)	
Efficiency	86% or more	90% or more
Parallel connection ^{*3}	Up to 5 units	

*1 The pulse width of the inrush current is 5ms or less.

*2 For parallel operation, this power supply unit changes output voltage according to load. Therefore, this power supply unit is for an exclusive use for IAI controllers.

*3 Parallel connection is impossible on the following conditions:

* Parallel connection of PSA-24 (without fan) and PSA-24L (with fan).

* Parallel connection with power unit other than this power supply unit.

* Parallel connection with PS-24.

External dimensions

PSA-24

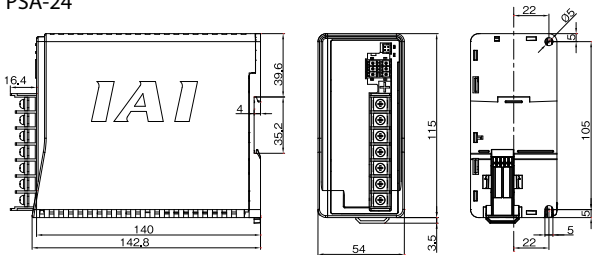

PSA-24L

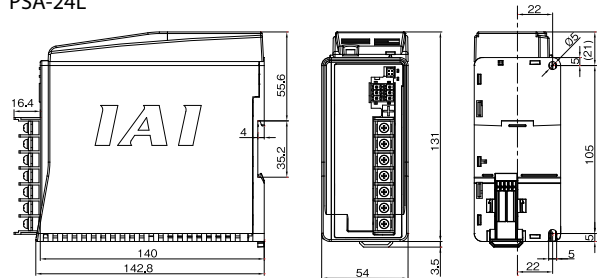

Maintenance parts

Fan unit

■ Description Option for forced cooling of the driver unit.

■ Model **RCON-FU**



for 200V driver

■ Model **RCON-FUH**



Dummy plug

for RSEL

■ Model **DP-4S**



for 200 driver

■ Model **DP-6**



Connector conversion cable

■ Feature It converts touch panel teaching pendant and RS232C cable Dsub25 pin connector to RSEL teaching connector. (The cable comes with TB-02/TB-03-SJ, IA-101-X-MW-JS).

■ Model **CB-SEL-SJS002**



System I/O connector

■ Description Connector for emergency stop signal input and external signal to switch operation mode.

For RSEL

■ Model **DFMC1,5/8-ST-3,5(RSEL)**

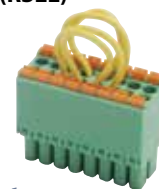

Drive power cutoff connector

■ Description A connector for drive power cutoff.

For 24V driver

■ Model **DFMC1,5/2-STF-3,5**



200V power supply connector

for 200V power supply

■ Model **SPC5/4-STF-7,62**



Regenerative resistance unit

■ Description This unit converts the regenerative current that generates when motor slows down into heat. The 200V driver unit and 200V power unit are equipped with internal regenerative resistor. However, when energy by speed reduction generates at the same timing, external regenerative resistance unit(s) is/are needed.

■ Model **RESU-s** (standard) / **RESUD-2** (DIN rail mount spec.)

* When two regenerative resistance units are needed, use one each of RESU-2 and RESU-1. (See the general catalog).

Specifications

Model	RESU-2	RESUD-2
Mass	approx. 0.4 kg	
Internal regenerative resistor	235Ω 80W	
Mounting method	Screw mount	DIN rail mount
Accessory cable	CB-SC-REU010	

External dimensions

<RESU-2>

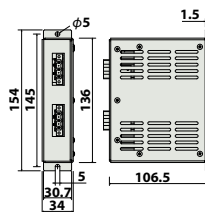

<RESUD-2>

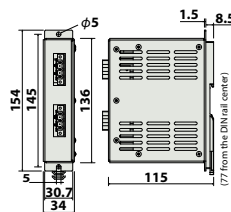

Maintenance parts (cable)

When ordering a replacement cable, etc. after purchase of the robot, specify the model number from the tables below.

Actuator		Connecting cable
Type	Configured axis	Motor & encoder cable (-RB: Robot cable)
CRS-XBA CRS-XGA CRS-XZCY CRS-XZCZ CRS-XZDY CRS-XZDZ	All axes	CB-ADPC-MA□□□(-RB)
CRS-XBB CRS-XGB CRS-XZEY CRS-XZEZ	R, B and T axes	

Actuator		Connecting cable		
Type	Configured axis	Motor cable	Motor robot cable	Encoder robot cable
CRS-XBB CRS-XGB CRS-XZEY CRS-XZEZ	X, Y and Z axes	CB-RCC1-MA □□□	CB-X2-MA □□□	CB-X1-PA □□□

Model **CB-ADPC-MPA□□□/CB-ADPC-MPA□□□-RB**

* Specify cable length (L) in □□□.
Up to 15m is available for CRS. (Ex.) 030=3m

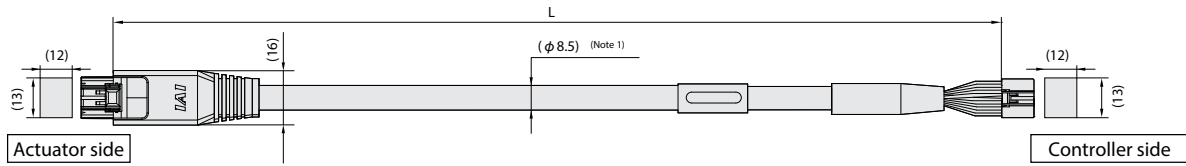

Minimum bending R 5m or less r=68mm or more (dynamic bending condition)
5m or more R=73mm or more (dynamic bending condition)

* Robot cables are of flex resistance specification. Use a robot cable when used inside the cable track.

(Note 1) When cable length is 5m or longer, it is φ 9.1.

DF62DL-24S-2.2C (Hirose)					DF62DL-24S-2.2C (Hirose)				
Color	Signal name			Pin No.	Pin No.	Signal name			Color
	DC	AC	PC			PC	AC	DC	
Blue(AWG22/19)	U	U	ΦA	3	3	ΦA	U	U	Blue(AWG22/19)
Orange(AWG22/19)	V	V	VMM	5	5	VMM	V	V	Orange(AWG22/19)
Brown(AWG22/19)	-	-	ΦB	10	10	ΦB	-	-	Brown(AWG22/19)
Gray(AWG22/19)	-	-	VMM	9	9	VMM	-	-	Gray(AWG22/19)
Green(AWG22/19)	W	W	Φ A	4	4	Φ A	W	W	Green(AWG22/19)
Red(AWG22/19)	-	-	Φ B	15	15	Φ B	-	-	Red(AWG22/19)
Blue(AWG26)	A+	A+	SA(mABS)	12	12	SA(mABS)	A+	A+	Blue(AWG26)
Orange(AWG26)	A-	A-	SB(mABS)	17	17	SB(mABS)	A-	A-	Orange(AWG26)
Green(AWG26)	B+	B+	A+	1	1	A+	B+	B+	Green(AWG26)
Brown(AWG26)	B-	B-	A-	6	6	A-	B-	B-	Brown(AWG26)
Gray(AWG26)	HS1_IN	Z+/SA(mABS)	B+	11	11	B+	Z+/SA(mABS)	HS1_IN	Gray(AWG26)
Red(AWG26)	HS2_IN	Z-/SB(mABS)	B-	16	16	B-	Z-/SB(mABS)	HS2_IN	Red(AWG26)
Black(AWG26)	-	VPS/BAT-	VPS	18	18	VPS	VPS/BAT-	-	Black(AWG26)
Yellow(AWG26)	-	BK+	LS+	8	8	LS+	BK+	-	Yellow(AWG26)
Blue(AWG26)	-	LS+	BK+	20	20	BK+	LS+	-	Blue(AWG26)
Orange(AWG26)	-	LS-	BK-	2	2	BK-	LS-	-	Orange(AWG26)
Gray(AWG26)	VCC	VCC	VCC	21	21	VCC	VCC	VCC	Gray(AWG26)
Red(AWG26)	GND	GND	GND	7	7	GND	GND	GND	Red(AWG26)
Brown(AWG26)	-	BK-	LS-	14	14	LS-	BK-	-	Brown(AWG26)
Green(AWG26)	HS3_IN	LS_GND	LS_GND	13	13	LS_GND	LS_GND	HS3_IN	Green(AWG26)
-	-	-	-	19	19	-	-	-	-
Pink(AWG26)	-	BAT+	CF_VCC	22	22	CF_VCC	BAT+	-	Pink(AWG26)
-	-	-	-	23	23	-	-	-	-
Black(AWG26)	FG	FG	FG	24	24	FG	FG	FG	Black(AWG26)

Model **CB-RCC1-MA**□□□□/ **CB-X2-MA**□□□□

* Indicate the cable length (L) in □□□□, maximum 15m for CRS. (Ex.) 080=8m

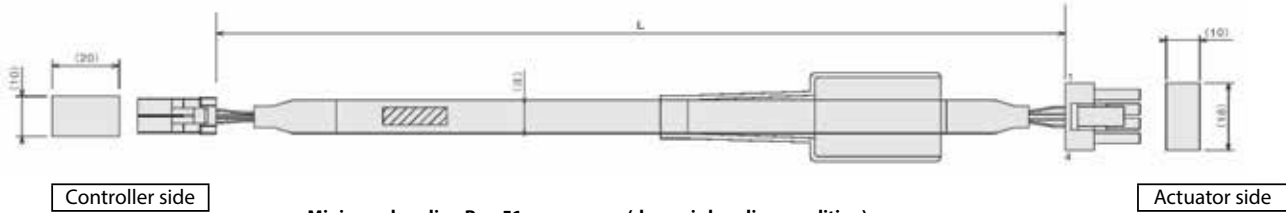

Minimum bending R r=51mm or more (dynamic bending condition)
 * Only robot cables can be used in the cable track.
 Non-robot cables are $\Phi 7.6$ and robot cables are $\Phi 8.5$.

F35FDC-04V-K (JST)

Wiring	Color	Signal	No.
0.75sq (crimped)	Red	U	B1
	White	V	B2
	Black	W	A1
	Green	PE	A2

SLP-04V (JST)

No.	Signal	Color	Wiring
1	U	Red	0.75sq (crimped)
2	V	White	
3	W	Black	
4	PE	Green	

Model **CB-X1-PA**□□□□

* Indicate the cable length (L) in □□□□, maximum 15m for CRS. (Ex.) 080=8m

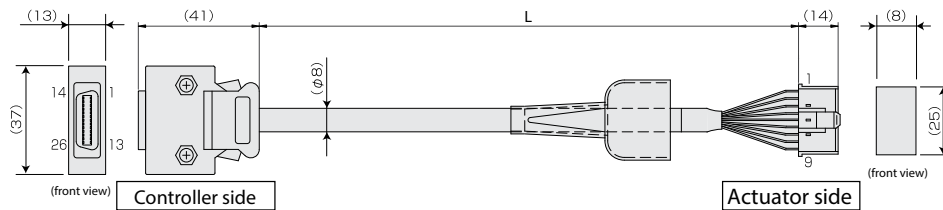

Minimum bending R r=44mm or more (dynamic bending condition)
 * The robot cable is used as standard.

Wiring	Color	Signal	No.
-	-	-	10
-	-	-	11
-	-	E24V	12
-	-	0V	13
-	-	LS	26
-	-	CREEP	25
-	-	OT	24
-	-	RSV	23
-	-	-	9
-	-	-	18
-	-	-	19
-	-	A+	1
-	-	A-	2
-	-	B+	3
-	-	B-	4
-	-	Z+	5
-	-	Z-	6
Orange		SRD+	7
Green		SRD-	8
Purple		BAT+	14
Gray		BAT-	15
Red		VCC	16
Black		GND	17
Blue		BKR-	20
Yellow		BKR+	21
-	-	-	22

Shield is clamp-connected to the hood.

Drain wire and shield braided

No.	Signal	Color	Wiring
1	BAT+	Purple	AWG26 (crimped)
2	BAT-	Gray	
3	SD	Orange	
4	SD	Green	
5	VCC	Red	
6	GND	Black	
7	FG	Drain	
8	BK-	Blue	
9	BK+	Yellow	

IAI America, Inc.

USA Headquarters & Western Region (Los Angeles): 2690 W. 237th Street, Torrance, CA 90505 (800) 736-1712

Midwest Branch Office (Chicago) : 110 E. State Pkwy, Schaumburg, IL 60173 (800) 944-0333

Southeast Branch Office (Atlanta): 1220 Kennestone Circle, Suite 108, Marietta, GA 30066 (678) 354-9470

www.intelligentactuator.com

JAPAN Headquarters: 577-1 Obane, Shimizu-ku, Shizuoka-shi, Shizuoka, 424-0103, JAPAN

The information contained in this product brochure may change without prior notice due to product improvements.

IAI Industrieroboter GmbH

Ober der Röth 4, D-65824 Schwalbach am Taunus, Germany

IAI (Shanghai) Co., Ltd.

Shanghai Jiahua Business Center A8-303, 808,
Hongqiao Rd., Shanghai 200030, China

IAI Robot (Thailand) Co., Ltd.

825 Phairokijja Tower 7th Floor, Debaratana Rd.,
Bangna Nuea, Bangna, Bangkok 10260, Thailand