

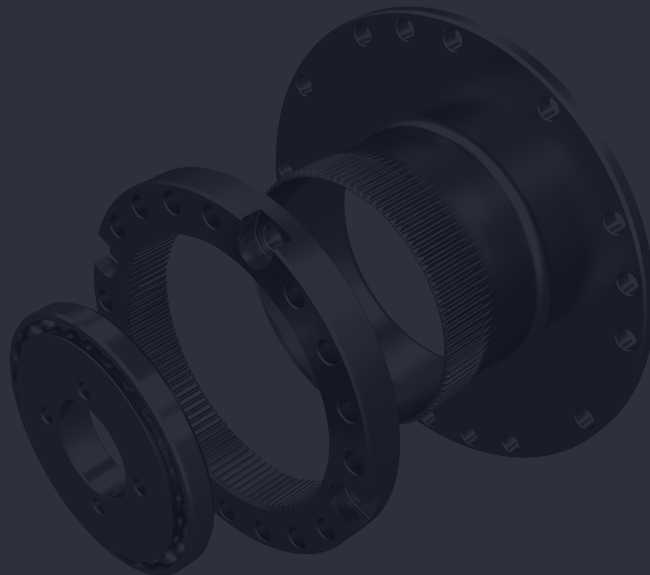

HARMONIC

SOLUTIONS



Precision. Motion Control. Technology.



Cone Drive is a world leader in precision motion control technology. We work with our customers every step of the way – from design specs to the final solution – to create highly precise, highly specific products that keep our customers' technology at the forefront of their industry. Cone Drive offers engineering support, unique solutions, and innovative technology across a breadth of markets and products to drive your company forward.



TABLE OF CONTENTS

CONE DRIVE HARMONIC SOLUTIONS®

PRODUCT RANGE	4
ONLINE CONFIGURATOR	8
SPECIFICATIONS	10
APPLICATIONS	11
OPERATING PRINCIPLES	12
ROTATIONAL DIRECTION & REDUCTION RATIO	13
UNIT DESIGNATION	16
PRODUCT HIERARCHY	17
CUP DIMENSIONAL DRAWINGS	18
HAT DIMENSIONAL DRAWINGS	20
RING DIMENSIONAL DRAWINGS	22
DEFINITIONS FOR RATINGS & SPECIFICATIONS	24
TORSIONAL STIFFNESS CURVE	26
POSITIONAL ACCURACY & VIBRATIONS	27
RATINGS	28
PRODUCT SELECTION PROCESS	34
GEARHEAD INSTALLATION	42
COMPONENT SET INSTALLATION	44
OLDHAM INPUT ASSEMBLY	46
HIGH PERFORMANCE L1 GREASE	47
INSTALLATION, OPERATION, & MAINTENANCE INSTRUCTIONS	48

Serving an entire spectrum of mechanical drive applications from food, energy, mining and metal; to automotive, aerospace and marine propulsion, we are your source for drive solutions.

INDUSTRIAL SOLUTIONS

SERIES HP

Worm gearbox with double-enveloping worm gearing. Available in single, double and triple reductions



SERIES HP-A

Universal metric housing featuring double-enveloping gearing & drywell feature



SERIES B

Industrial duty worm gearbox featuring Conex® gearing

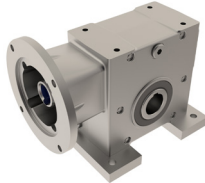

DUO DRIVE

Dual gears on parallel output shafts



SLEWING SOLUTIONS

Versatile slew bearings and slew drives featuring external, internal and without teeth options in a low profile, ready-to-install package



STAINLESS NEMA

Smooth, contoured stainless steel housing (316), IP69K rated, right angle gearbox



DOUBLE-ENVELOPING WORM GEAR SET

Available in standard sizes, ratios and backlash options along with custom worm gear sets



PRECISION MOTION SOLUTIONS

SERIES W

Precision right angle servo gearbox

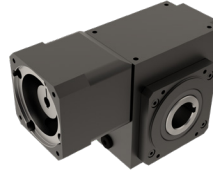

SERIES RC

Moderate precision right angle servo gearbox

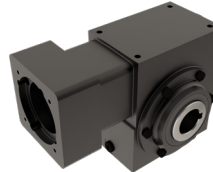

SERIES S

Value engineered right angle servo gearbox

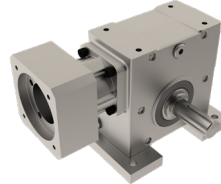

SERIES LE / P

In-line helical geared motors & reducers and precision planetary servo gearbox



HARMONIC

Cone Drive Harmonic Solutions® offer the ultimate in precision motion control technology

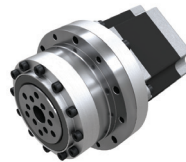

STAINLESS SERVO

Smooth, contoured stainless steel housing (316), IP69K rated right angle gearbox



HP SERVO

This double-enveloping worm gearing, high torque gearbox meets the most demanding needs as servo motor capacities increase



We can create custom engineered transmission solutions of any size and configuration.

Cone Drive **HARMONIC SOLUTIONS®**

CBC

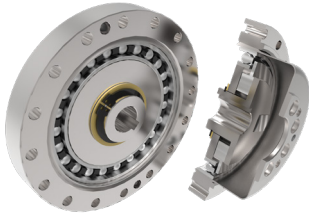

- Space efficient, simple design
- Design conducive to machinery integration requirements
- Complete customization available
- Dimensionally interchangeable with competitive products
- Compare to 'High Torque' version from competitors'

CBCF-

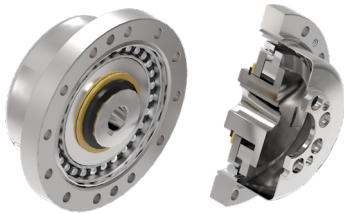

- Space efficient, simple design
- Design conducive to machinery integration requirements
- Complete customization available
- Same internal components as standard CBC component gearset
- Bolt patterns to match competitors' lower torque 'F' style

CBC-L



- Simplified design reduces mass up to 45%
- Large bore allows cable / equipment to pass through gearing
- Design conducive to machinery integration requirements
- Complete customization available

CBG

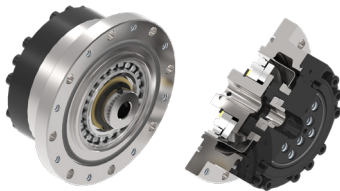

- Housed output with cross roller bearing included
- Complete customization available
- Dimensionally interchangeable with competitive products
- Compare to 'High Torque' version from competitors'

CBGF-

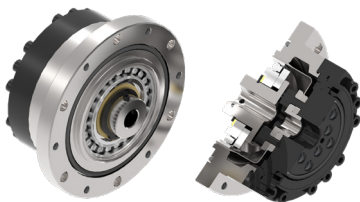

- Housed output with cross roller bearing included
- Same internal components as standard CBG gearhead
- Complete customization available
- Bolt patterns to match competitors' lower torque 'F' style

Cone Drive **HARMONIC SOLUTIONS®**



HBC

- Space efficient, simple design
- Design conducive to machinery integration requirements
- Complete customization available
- Dimensionally interchangeable with competitive products
- Compare to 'High Torque' version from competitors'

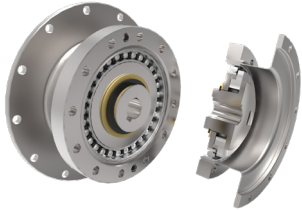

HBCF-

- Space efficient, simple design
- Design conducive to machinery integration requirements
- Complete customization available
- Same internal components as standard HBC component gearset
- Bolt patterns to match competitors' lower torque 'F' style



HBG

- Housed output with cross roller bearing included
- Complete customization available
- Dimensionally interchangeable with competitive products
- Compare to 'High Torque' version from competitors'



HBGT-

- Housed output with cross roller bearing included
- Large hollow shaft allows cable / equipment to pass through gearing
- Complete customization available
- Same internal components as standard HBG gearhead
- Compare to 'High Torque' version from competitors'

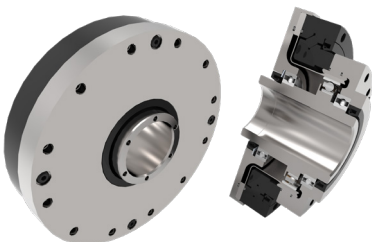

HBGHL

- Housed output with cross roller bearing included
- Large hollow shaft allows cable / equipment to pass through gearing
- Complete customization available
- Same internal components as standard HBG gearhead
- Fully supported and sealed gearhead

Cone Drive HARMONIC SOLUTIONS®

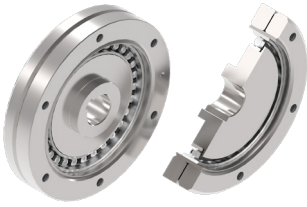

RLC

- Axially compact design for tight spaces - Low backlash < 3 arcmin
- Ratios up to 160:1 in a single stage
- Complete customization available

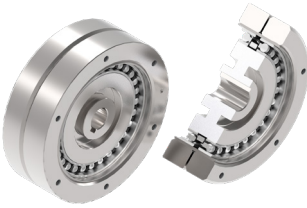

RBC

- Higher torque capacity than RLC
- Axially compact design for tight spaces - Low backlash < 3 arcmin
- Ratios up to 160:1 in a single stage
- Complete customization available

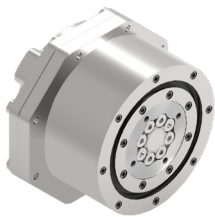

GMA-S (Solid)



GMA-H (Hollow)

Cone Drive GEARMOTOR ACTUATORS

- High power density with minimal axial length
- High motor efficiency
- Flexible form factor
- Complete customization available
- Complete gearmotor assembly for your project

Contact ae@conedrive.com for further information on our specialized solutions

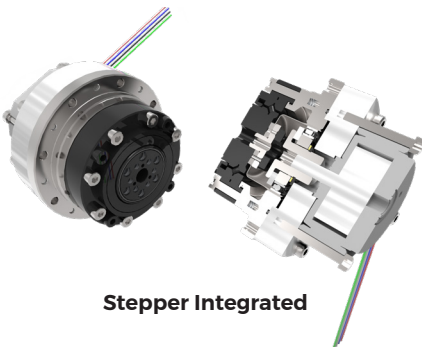

Stepper Integrated

Configure Your Harmonic Unit Online

www.ConeTools.com

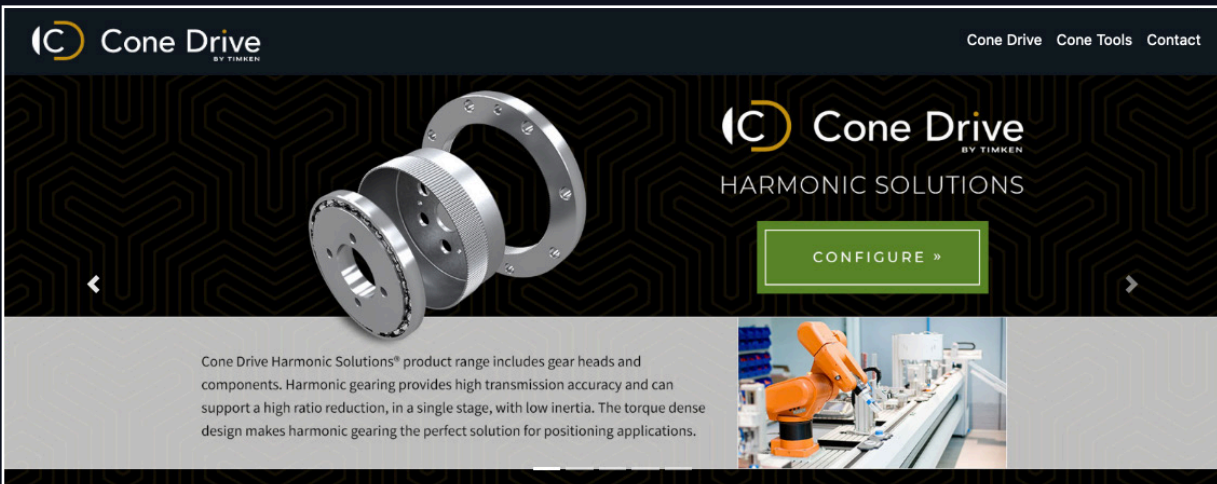

Cone Drive BY TIMKEN Cone Drive BY TIMKEN Cone Drive Cone Tools Contact

Cone Drive HARMONIC SOLUTIONS

CONFIGURE »

Cone Drive Harmonic Solutions® product range includes gear heads and components. Harmonic gearing provides high transmission accuracy and can support a high ratio reduction, in a single stage, with low inertia. The torque dense design makes harmonic gearing the perfect solution for positioning applications.

Servo Rated

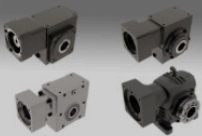

AccuMate Servo

CONFIGURE

Guided selection of AccuDrive products starting with Servo motor.

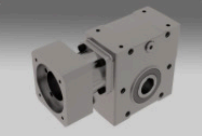

AccuDrive - Series S

CONFIGURE

A flexible and economical servo interfacing right angle gearbox solution.



AccuDrive - Series W

CONFIGURE

A high precision, high torque capacity right angle servo interfacing gearbox solution with a range of backlash options.

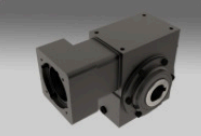

AccuDrive - RG Servo

CONFIGURE

A moderate precision, high torque capacity servo interfacing right angle gearbox solution.



Accudrive - In-line

CONFIGURE

In-line servo interfacing precision planetary gearboxes.



Model HP Servo

CONFIGURE

High torque and high shock load capacity servo interfacing right angle gearbox solution.

Visit ConeTools.com and Click "CONFIGURE" Harmonic

Precision Motion



Harmonic

CONFIGURE

In-line motion control solutions with the highest precision available in gearheads and component sets.

Guided Harmonic Selection

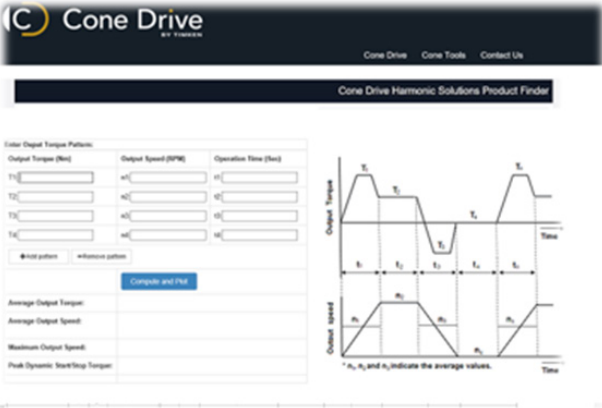

FOR GUIDED SELECTION CLICK HERE



GUIDED SELECTION:

Select criteria based on your application and need and let our configurator help determine which specific unit is a best fit.

Direct Harmonic Product Finder

DIRECT SELECTION:

Take a direct approach and build your harmonic unit based on the style that fits your needs.

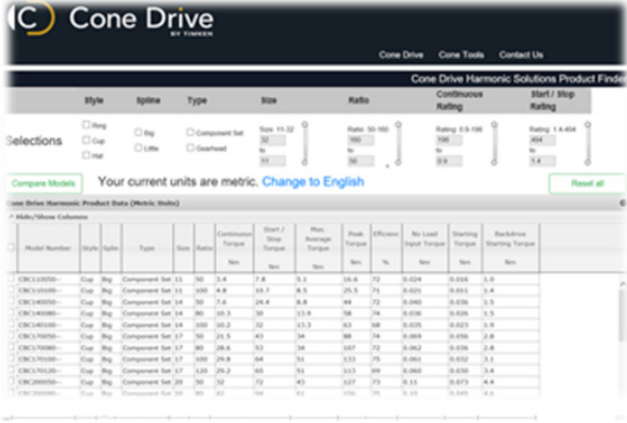

FOR DIRECT SELECTION CLICK HERE

ULTIMATE PRECISION. ULTIMATE CONTROL.

Harmonic gearing is low to zero backlash by design. It provides high transmission accuracy and can support a high ratio reduction in a single stage with lower inertia. The highly accurate, torque dense design makes harmonic gears a great solution for robotic and positioning applications.



Ring Component

PRODUCT SPECIFICATIONS

Sizes: 14, 17, 20, 25, 32

Flex Spine Sizes: Single & double input bearing

Configuration: Component set only. No gearhead option

Continuous Output Torque: Up to 136 Nm (1204 in. lb)

Peak Output Torque: Up to 330 Nm (2921 in. lb)

Gear Ratios: 50:1 to 160:1

Standard Input Options: Keyed or set screws

Custom Input Options: Through bore, Dowel Pins, Tapped Holes, Piloted, Stepper/Servo Motor Ready, Special Materials and Coatings

Hat Component & Gearhead

PRODUCT SPECIFICATIONS

Sizes: 14, 17, 20, 25, 32

Configuration: Component gearset or gearhead. Sealed, through bore, lightweight, and other options available

Continuous Output Torque: Up to 172 Nm (1522 in. lb)

Peak Output Torque: Up to 824 Nm (7293 in. lb)

Gear Ratios: 50:1 to 160:1; ratio offerings are size dependent

Standard Input Options: Keyed or set screws. Includes Oldham style coupling

Custom Input Options: Through bore, Solid Input, Dowel Pins, Tapped Holes, Piloted, Stepper/Servo Motor Ready, Special Materials and Coatings

Cup Component & Gearhead

PRODUCT SPECIFICATIONS

Sizes: 11, 14, 17, 20, 25, 32

Configurations: Component gearset or gearhead. Large bore (lightweight) and other options available

Continuous Output Torque: Up to 172 Nm (1522 in. lb)

Peak Output Torque: Up to 824 Nm (7293 Nm)

Gear Ratios: 50:1 to 160:1; ratio offerings are size dependent

Standard Input Options: Keyed or set screws. Includes Oldham style coupling

Custom Input Options: Solid Input, Dowel Pins, Tapped Holes, Piloted, Stepper/Servo Motor Ready, Special Materials and Coatings



AUTOMATION & ROBOTICS | MEDICAL | SATELLITE COMMUNICATION | MILITARY & DEFENSE



With each revolution of the wave generator, the OD spline moves two teeth in the opposite direction. One tooth for each 180 degrees of wave generator rotation. A high gear reduction is possible because many gear teeth can be formed into the OD spline and mating ID spline.

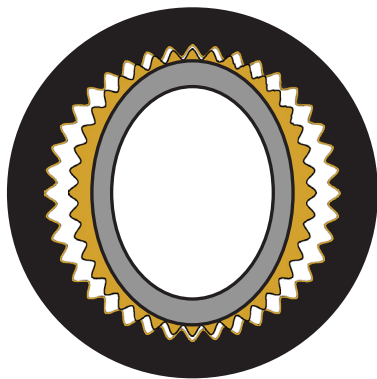

KEY

 **ID Spline (circular spline)**

Rigid, circular ring with gear teeth on the inner diameter

 **OD Spline (flex spline)**

Thin alloy steel designed for increased compliance in radial deflection

 **Wave Generator**

Elliptical disc with an outer ball bearing

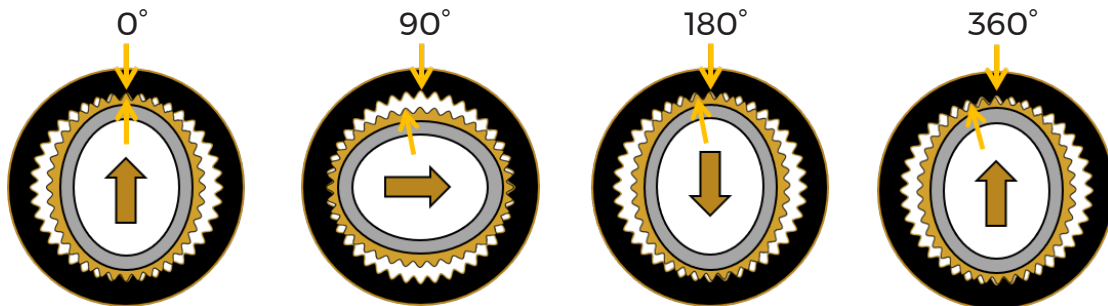

⚠ WARNING: Failure to observe the following warnings could lead to a risk of death or serious bodily harm.

Do not exceed catalog ratings and follow all catalog guidelines and precautions.

Do not use standard catalog products in explosive or corrosive environments.

Improper handling, installation, misuse and not adhering to the guidelines, procedures and lubrication applications outlined hereafter may result in damage to the product, cause physical injury or harm, and void the product warranty.

Please contact Cone Drive at ae@conedrive.com for applications involving human transport or contact, medical equipment, nuclear equipment, aircraft equipment, space or vacuum equipment, or other safety related applications

Reduction Ratio: Ring Style (RLC/RBC)

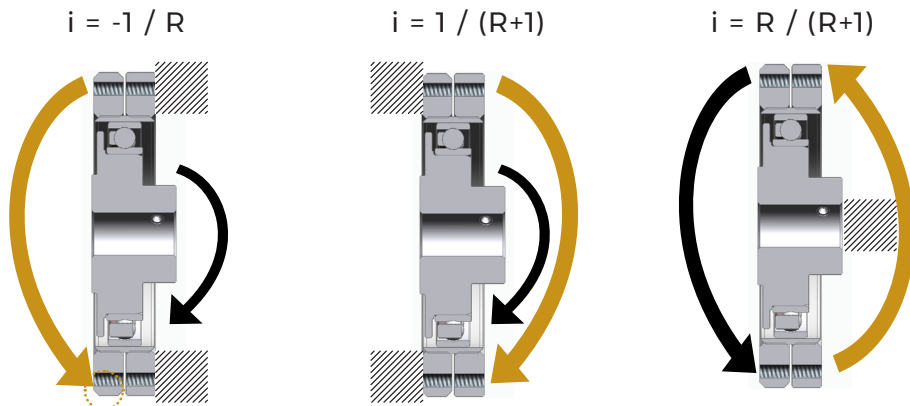

Larger chamfer indicates secondary ID spline

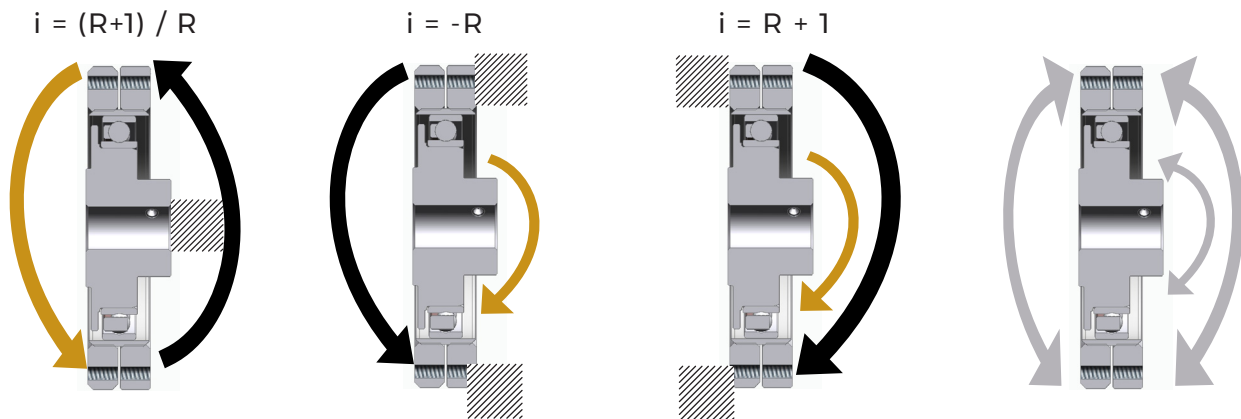



VARIABLE RATIO:

A combination of final drive ratios available with all components in motion

i = Final Drive Ratio
 R = Reducer Catalog Ratio

 Stationary

Input   Output

Reduction Ratio: Hat Style (HBC/HBG)

$i = -1 / R$

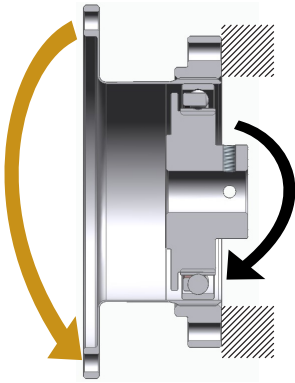

$i = 1 / (R+1)$

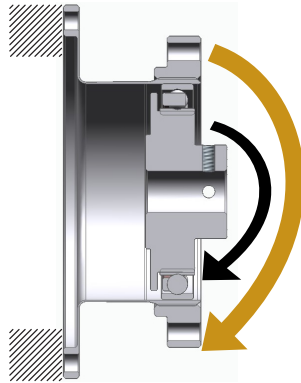

$i = R / (R+1)$

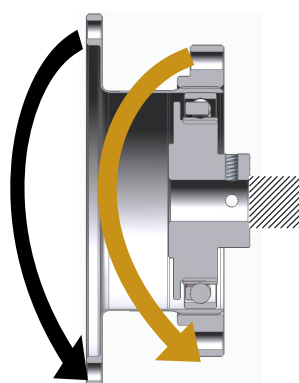

$i = (R+1) / R$

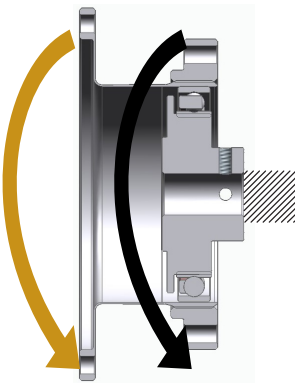

$i = -R$

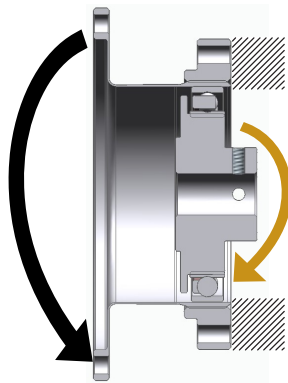

$i = R + 1$

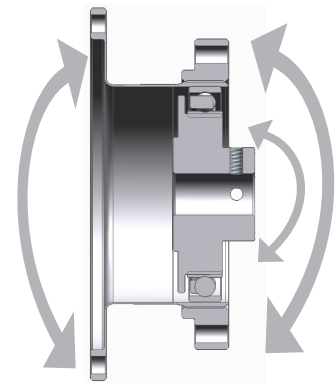
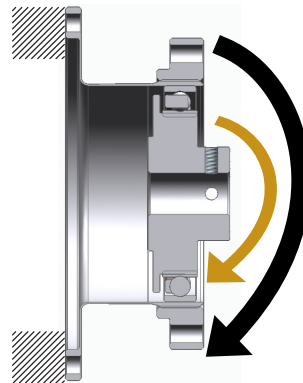

VARIABLE RATIO:

A combination of final drive ratios available with all components in motion

i = Final Drive Ratio
 R = Reducer Catalog Ratio

Stationary

Input Output

Reduction Ratio: Cup Style (CBC/CBG)

$$i = -1 / R$$

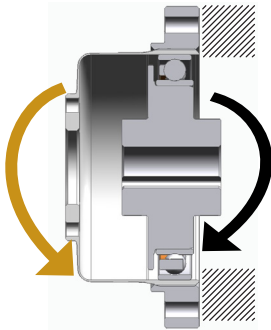

$$i = 1 / (R+1)$$

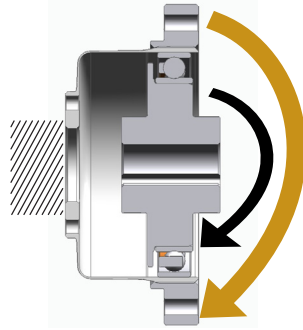

$$i = R / (R+1)$$

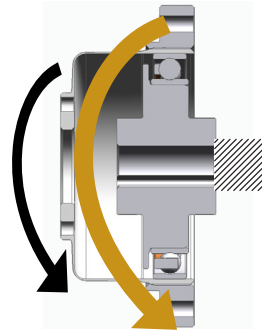

$$i = (R+1) / R$$

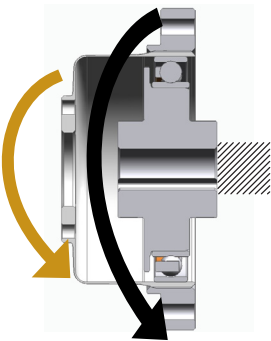

$$i = -R$$

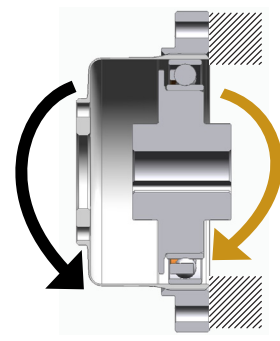

$$i = R + 1$$

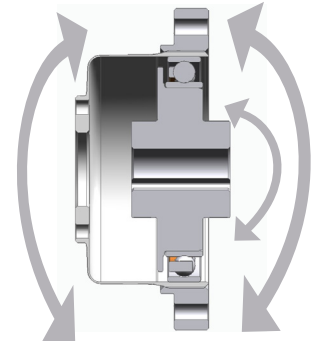
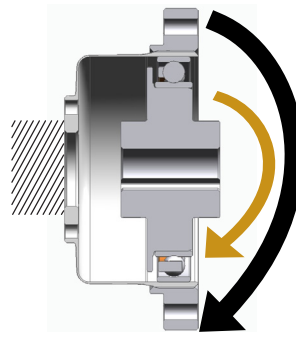

VARIABLE RATIO:

A combination of final drive ratios available with all components in motion

i = Final Drive Ratio
 R = Reducer Catalog Ratio

 Stationary

Input   Output

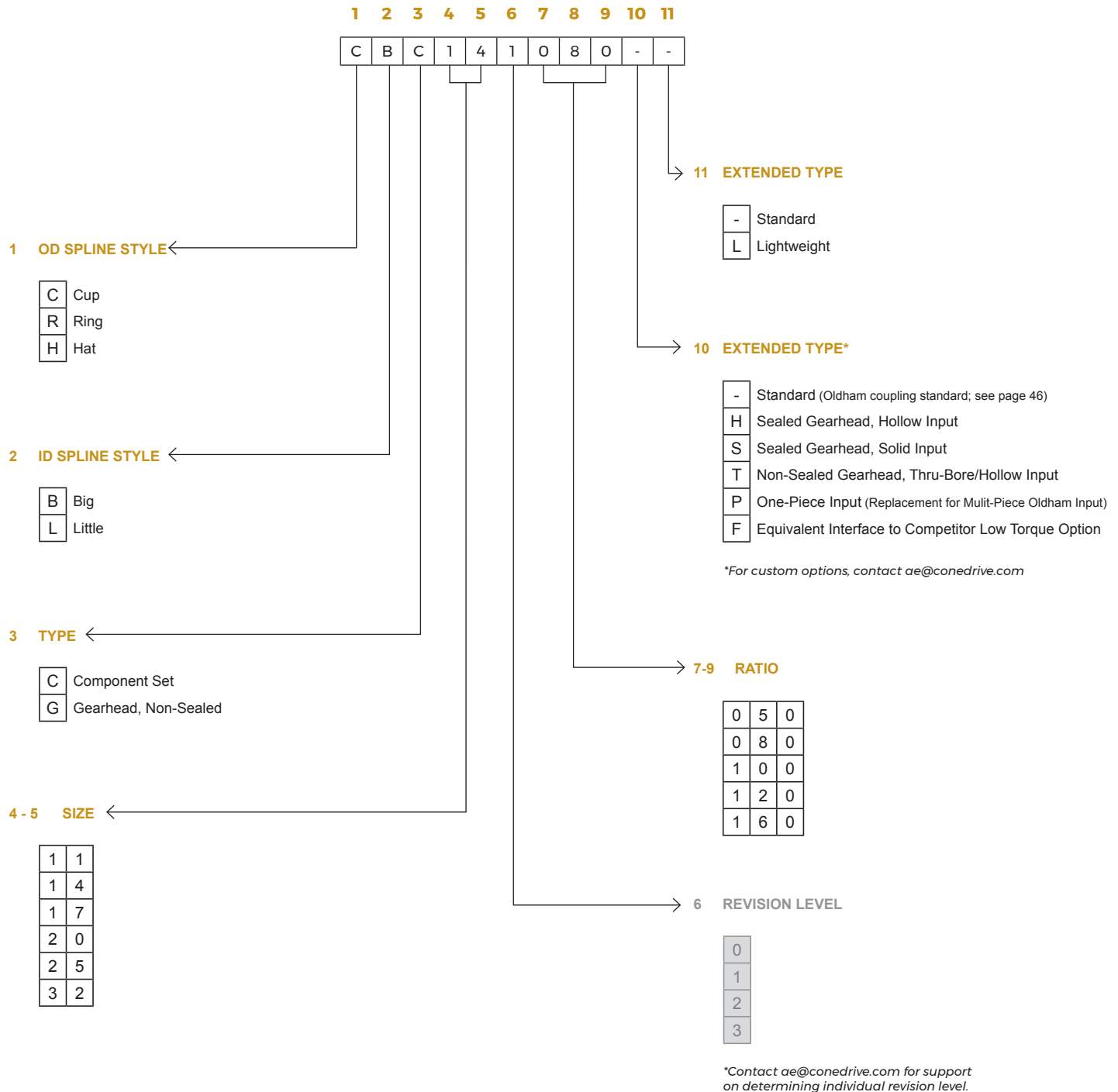

We reserve the right to improve or change product design and specifications without notice.

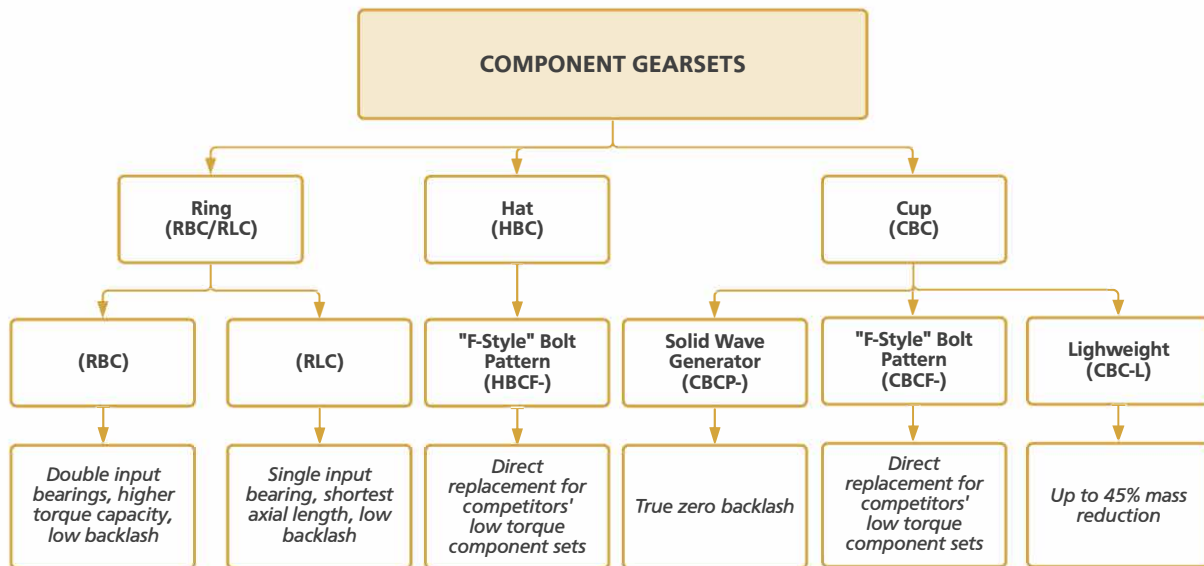
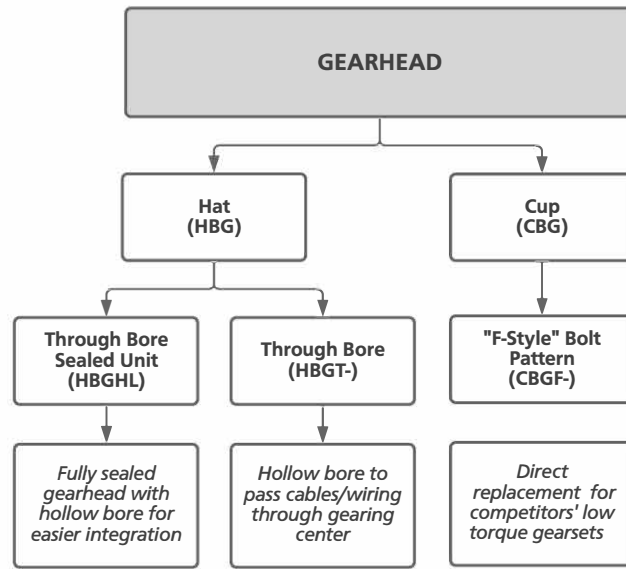

Style	Available Sizes	Through Bore	Backlash	Torsional Stiffness	Torque Capacity	Lifetime (L ₁₀)
			arcmin			hrs
CBC	11 - 32	Available (small)	Ultra Low to Zero	Highest	10,000	
HBC	14 - 32	Available (large)	Ultra Low to Zero	Highest	10,000	
RLC	14 - 32	Available (large)	< 3	Lowest	3,000	
RBC	14 - 32	Available (large)	< 3	Medium	3,000	
CBG	11 - 32	Available (small)	Ultra Low to Zero	Highest	10,000	
HBG	14 - 32	Available (large)	Ultra Low to Zero	Highest	10,000	

Harmonic Cup - Component Set Dimensional Drawings

NOTES

- 1 RECOMMENDED ASSEMBLY TOLERANCE FOR PROPER OPERATION
- 2 RECOMMENDED HOUSING /CASE DIMENSIONS FOR PROPER CLEARANCE AND LUBRICANT RETENTION
- 3 IF THE APPLICATION REQUIRES OPERATION SUCH THAT THE WAVE GENERATOR IS MOUNTED VERTICAL FACING UPWARD FOR EXTENDED PERIODS, INCREASE THE NOTED DIMENSION TO 2 x THE CURRENT VALUE.
- 4 RECOMMENDED MATING FEATURE TOLERANCE
- 5 REFER TO SOLID MODEL FOR FEATURES NOT DEFINED

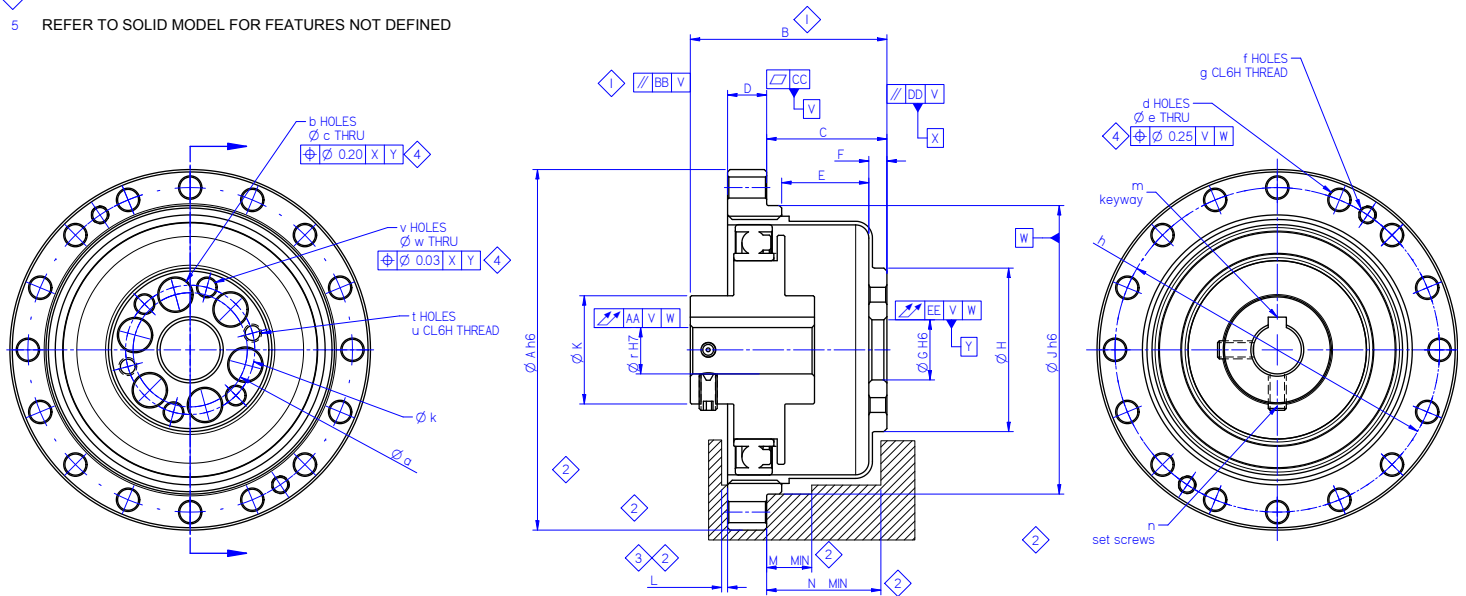

*Solid model available on configurator

Cross hatched pattern indicates housing and is the responsibility of the customer

Size	ØA	B	C	D	E	F	ØC	ØH	ØJ	ØK	Øa	b	Øc	Øk	t	u	v	Øw	
(all units in mm unless otherwise noted)																			
11	40	25.5 - 25.8	14.4 - 14.7	5	2	2	6	17.8	31	11	12	6	3.4 ↓ THRU	15.2	-	-	2	2 - 2.08	
14	50	28.6 - 29	17.5 - 17.9	6	2	2.4	11	23	38	14	17	6	4.5 ↓ THRU	18.5	2	M3 x 0.5 ↓ THRU	4	2.5 - 2.6	
17	60	32.5 - 32.9	20 - 20.5	6.5	2.5	3	10	27.2	48	18	19	6	5.5 ↓ THRU	21.5	2	M3 x 0.5 ↓ THRU	4	3 - 3.1	
20	70	33.5 - 33.9	21.5 - 22.1	7.5	3	3	16	32	54	21	24	8	5.5 ↓ THRU	27	2	M3 x 0.5 ↓ THRU	4	3 - 3.1	
25	85	37 - 37.5	24 - 24.6	10	3	3	20	40	67	26	30	8	6.6 ↓ THRU	34	2	M4 x 0.7 ↓ THRU	4	4 - 4.1	
32	110	44 - 44.6	28 - 28.6	14	3	3.2	26	52	90	26	40	8	9 ↓ THRU	45	2	M5 x 0.8 ↓ THRU	4	5 - 5.1	

Size	d	Øe	f	g	Øh	m	n	Ør	Ød	Øi	Øj	L	M	N	AA	BB	CC	DD	EE
(all units in mm unless otherwise noted)																			
11	8	2.9 ↓ THRU	2	M2 x 0.45 ↓ THRU □ Ø2.9 ↓ 2	35	-	2 x M3 x 0.5 x 4	5	20	30	30	0.5	7	14	0.03	0.04	0.015	0.015	0.01
14	8	3.5 ↓ THRU	2	M3 x 0.5 ↓ THRU	44	-	2 x M3 x 0.5 x 4	6	25	38	38	1	-	17.1	0.03	0.04	0.02	0.02	0.015
17	16	3.5 ↓ THRU	2	M3 x 0.5 ↓ THRU	54	-	2 x M3 x 0.5 x 6	8	30	45	45	1	7.5	19	0.035	0.05	0.025	0.025	0.02
20	16	3.5 ↓ THRU	2	M3 x 0.5 ↓ THRU □ Ø3.5 ↓ 3.5	62	3 x 1.4+0.1	-	9	36	53	53	1.5	8	20.5	0.045	0.055	0.025	0.025	0.02
25	16	4.5 ↓ THRU	2	M4 x 0.7 ↓ THRU □ Ø4.5 ↓ 4	75	4 x 1.8+0.1	-	11	48	66	66	1.5	8	23	0.045	0.07	0.03	0.03	0.02
32	16	5.5 ↓ THRU	2	M5 x 0.8 ↓ THRU □ Ø5.5 ↓ 7	100	5 x 2.3+0.1	-	14	60	86	86	1.5	8	26.8	0.05	0.075	0.04	0.04	0.02

NOTES

- 1 RECOMMENDED ASSEMBLY TOLERANCE FOR PROPER OPERATION
- 2 RECOMMENDED HOUSING / CASE DIMENSIONS FOR PROPER CLEARANCE AND LUBRICANT RETENTION
- 3 IF THE APPLICATION REQUIRES OPERATION SUCH THAT THE WAVE GENERATOR IS MOUNTED VERTICAL FACING UPWARD FOR EXTENDED PERIODS, INCREASE THE NOTED DIMENSION TO 2x THE CURRENT VALUE
- 4 RECOMMENDED MATING FEATURE TOLERANCE
- 5 DO NOT REMOVE FACTORY INSTALLED HARDWARE. COMPONENT MISALIGNMENT AND/OR UNIT DAMAGE MAY RESULT.
- 6 REFER TO SOLID MODEL FOR FEATURES NOT DEFINED.

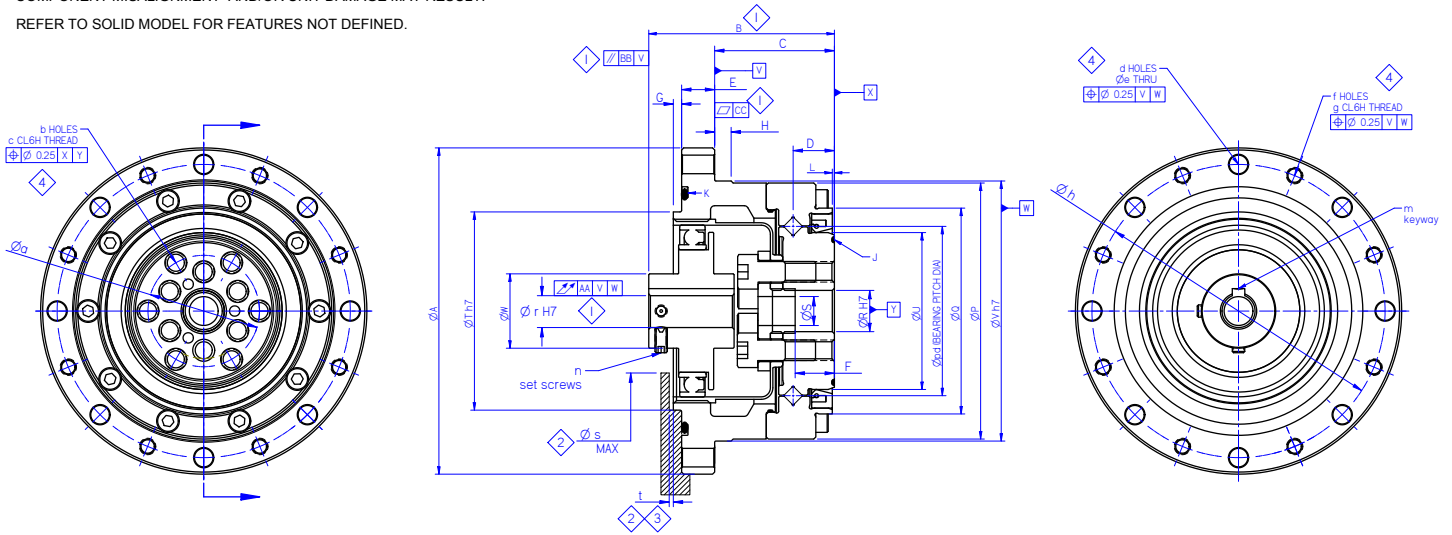

*Solid model available on configurator

Cross hatched pattern indicates housing and is the responsibility of the customer

Size	ØA	B	C	D	E	F	G	H	J	K	L	ØP	ØQ	ØR	ØS	ØT	ØU
(all units in mm unless otherwise noted)																	
11	65	36.95 - 37.25	23.5	8.5	6	8	1.5	3.5	23 ID x 0.5 O-RING	40.6 ID x 1.14 O-RING	0.45 - 0.55	50	36.7	6	3	36	25
14	73	40.9 - 41.3	27	9.5	7	9.4	2	3.5	29.0 x 0.5 O-RING	S50 O-RING	0.45 - 0.55	55	43	11	8	38	31
17	79	44.75 - 45.15	29	10	8	9.54	2	4	34.5 x 0.8 O-RING	S56 O-RING	0.45 - 0.55	62	50	10	7	48	38
20	93	45.2 - 45.6	28	9.8	10	9	3	5	40.6 x 1.14 O-RING	S67 O-RING	0.45 - 0.55	70	58	14	10	56	45
25	107	51.7 - 52.2	36	11.4	10	12.26	3	5	53.3 x 1 O-RING	S80 O-RING	0.45 - 0.55	85	73	20	15	67	58
32	138	61.7 - 62.3	45	13	12	14.2	3	4.5	S71 O-RING	S105 O-RING	0.95 - 1.05	112	96.3	26	20	90	78

Size	ØV	ØW	Øa	b	c	d	Øe	f	g	Øh	m	n	Øpd	Øs	t	AA	BB	CC
(all units in mm unless otherwise noted)																		
11	51	11	17	6	M4 x 0.7 ↓ 10 MAX	8	3.4 ↓ THRU	8	M3 x 0.5 ↓ THRU	58	-	2 x M3 x 0.5 x 4	30	20	0.5	0.03	0.04	0.015
14	56	14	23	6	M4 x 0.7 ↓ 11 MAX	8	4.5 ↓ THRU	8	M4 x 0.7 ↓ THRU	65	-	2 x M3 x 0.5 x 4	34	25	1	0.03	0.04	0.02
17	63	18	27	6	M5 x 0.8 ↓ 11 MAX	8	4.5 ↓ THRU	8	M4 x 0.7 ↓ THRU	71	-	2 x M3 x 0.5 x 6	41	30	1.0	0.035	0.05	0.025
20	72	21	32	8	M6 x 1.0 ↓ 11 MAX	8	5.5 ↓ THRU	8	M5 x 0.8 ↓ THRU	82	4 x 1.8+0.1	-	51	36	1.5	0.045	0.055	0.025
25	86	26	42	8	M8 x 1.25 ↓ 14 MAX	10	5.5 ↓ THRU	10	M5 x 0.8 ↓ THRU	96	5 x 2.3+0.1	-	62	47	1.5	0.06	0.07	0.03
32	113	26	55	8	M10 x 1.5 ↓ 17 MAX	12	6.6 ↓ THRU	12	M6 x 1 ↓ THRU	125	5 x 2.3+0.1	-	81	60	1.5	0.065	0.075	0.04

Harmonic Hat - Component Set Dimensional Drawings

NOTES

- 1 RECOMMENDED ASSEMBLY TOLERANCE FOR PROPER OPERATION
- 2 RECOMMENDED HOUSING / CASE DIMENSIONS FOR PROPER CLEARANCE AND LUBRICANT RETENTION.
- 3 IF THE APPLICATION REQUIRES OPERATION SUCH THAT THE WAVE GENERATOR IS MOUNTED VERTICAL FACING UPWARD FOR EXTENDED PERIODS, INCREASE THE NOTED DIMENSION TO 2 x THE CURRENT VALUE.
- 4 RECOMMENDED MATING FEATURE TOLERANCE
- 5 REFER TO SOLID MODEL FOR FEATURES NOT DEFINED.

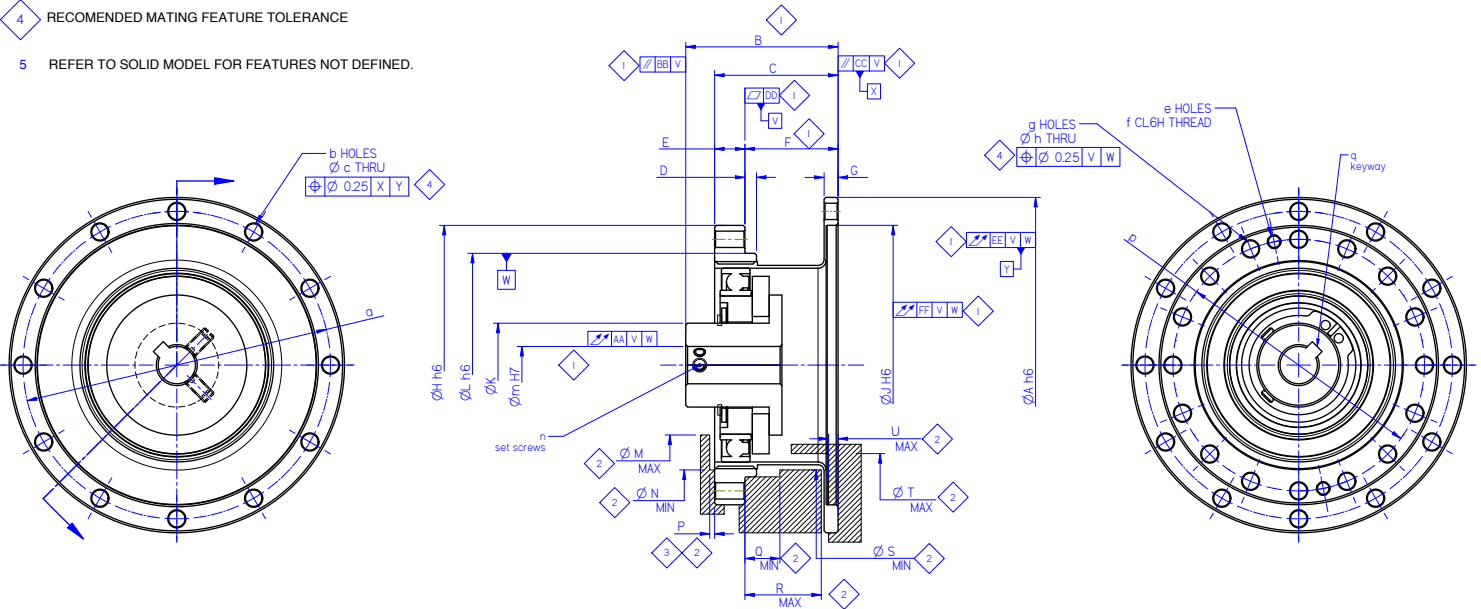

*Solid model available on configurator

Cross hatched pattern indicates housing and is the responsibility of the customer

Size	ØA	B	C	D	E	R	G	ØH	ØJ	ØK	Øa	b	c	e	f	g	Øh
(all units in mm unless otherwise noted)																	
14	60	28.6 - 29.0	23.5	2	6	17.5 - 17.9	2.4	50	48	6	54	8	3.5	2	M3 x 0.5	8	3.5
17	72	32.5 - 32.9	26.5	2.5	6.5	20.0 - 20.5	3	60	60	8	66	12	3.5	2	M3 x 0.5	16	3.5
20	82	33.5 - 33.9	29.3	3	7.5	21.5 - 22.1	3	70	70	9	76	12	3.5	2	M3 x 0.5	16	3.5
25	104	37.0 - 37.5	34.3	3	10	24.0 - 24.6	3.3	85	88	11	96	12	4.5	2	M4 x 0.7	16	4.5
32	134	44.0 - 44.6	42.3	3	14	28.0 - 28.6	3.6	110	114	14	124	12	5.5	2	M5 x 0.8	16	5.5

Size	Øm	n	p	q	ØM	ØN	P	Q	R	ØS	ØT	U	AA	BB	CC	DD	EE	FF
(all units in mm unless otherwise noted)																		
14	6	2 x M3 x 0.5 x 4	44	-	25	38	1	-	14.6	38	31	1.6	0.03	0.04	0.02	0.02	0.015	0.015
17	8	2 x M3 x 0.5 x 6	54	-	30	45	1	7.5	16.4	45	38	2	0.035	0.05	0.025	0.025	0.02	0.02
20	9	-	62	3 x 1.4+0.1	36	53	1.5	8	17.8	53	45	2	0.045	0.055	0.025	0.025	0.02	0.02
25	11	-	75	4 x 1.8+0.1	48	66	1.5	8	19.8	66	56	2	0.045	0.07	0.03	0.03	0.02	0.02
32	14	-	100	5 x 2.3+0.1	60	86	1.5	8	23.2	86	73	2	0.05	0.075	0.04	0.04	0.02	0.02

NOTES

- 1 RECOMMENDED ASSEMBLY TOLERANCE FOR PROPER OPERATION (SEE TABLE 1 FOR DEFINITION OF THE PRIMARY AND SECONDARY DATUMS REFERENCED IN REQUIREMENTS)
- 2 RECOMMENDED HOUSING / CASE DIMENSIONS FOR PROPER CLEARANCE AND LUBRICANT RETENTION.
- 3 IF THE APPLICATION REQUIRES OPERATION SUCH THAT THE WAVE GENERATOR IS MOUNTED VERTICAL FACING UPWARD FOR EXTENDED PERIODS, INCREASE THE NOTED DIMENSION TO 2 x THE CURRENT VALUE.
- 4 RECOMMENDED MATING FEATURE TOLERANCE.
- 5 DO NOT REMOVE FACTORY INSTALLED HARDWARE. COMPONENT MISALIGNMENT AND/OR UNIT DAMAGE MAY RESULT.
- 6 REFER TO SOLID MODEL FOR FEATURES NOT DEFINED.

Table 1: Mounting Datum Options
(Select tolerance control datums based on static mounting surface)

Datum	
Primary	Secondary
V	W
U	Y
X	Z

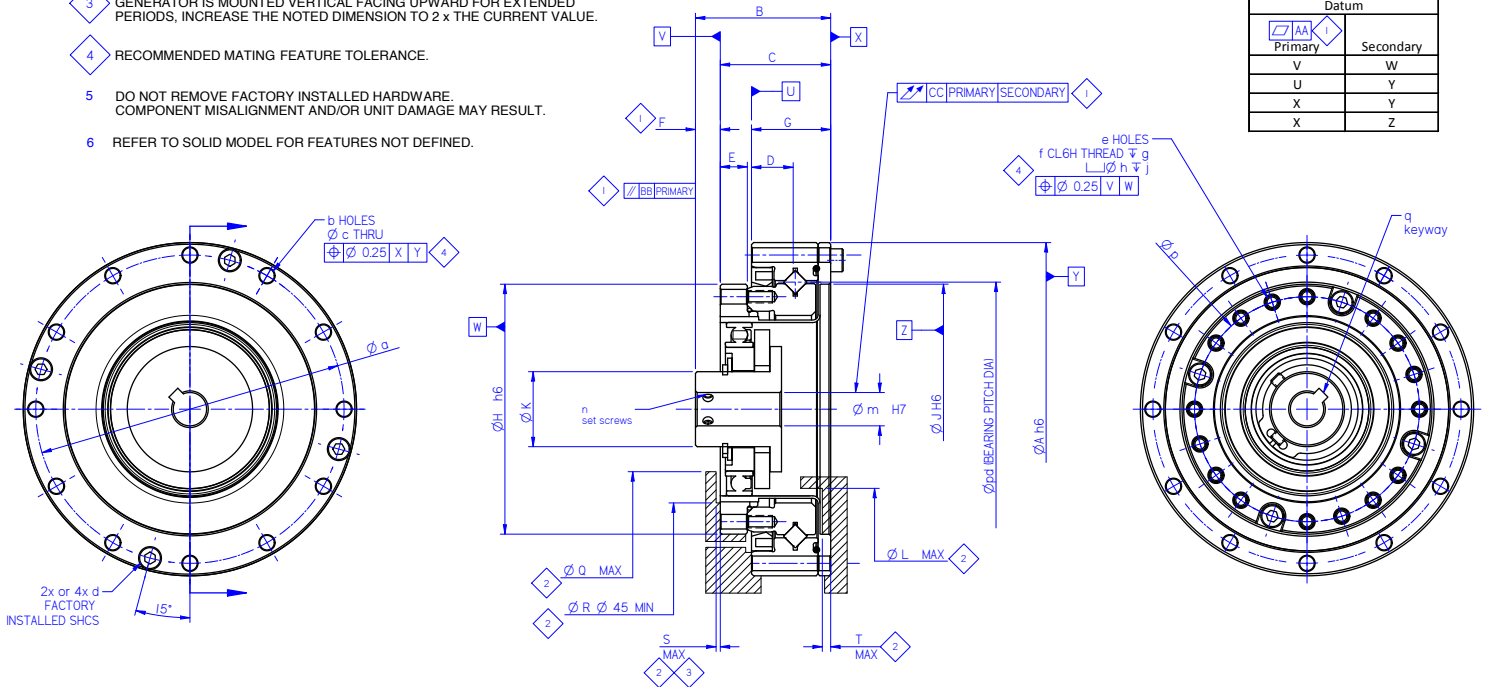

*Solid model available on configurator

Cross hatched pattern indicates housing and is the responsibility of the customer

Size	ØA	B	C	D	E	F	G	ØH	ØJ	ØK	Øa	b	c	d	e	f
(all units in mm unless otherwise noted)																
14	70	28.59	23.49	9.2	6	4.9 - 5.3	16.5	50	48	14	64	8	3.5	2x M3	8	M3 x 0.5
17	80	32.45	26.5	10	6.5	5.75 - 6.15	19	60	60	18	74	12	3.5	4x M3	16	M3 x 0.5
20	90	33.4	29	10.8	7.5	4.2 - 4.6	20.5	70	70	21	84	12	3.5	4x M3	16	M3 x 0.5
25	110	36.95	34	11.3	10	2.7 - 3.2	22	85	88	26	102	12	4.5	4x M3	16	M4 x 0.7
32	142	44	42	14.2	14	1.7 - 2.3	27	110	114	26	132	12	5.5	4x M4	16	M5 x 0.8

Size	g	Øh	j	Øm	n	p	q	Øpd	ØQ	ØR	S	T	ØL	AA	BB	CC
(all units in mm unless otherwise noted)																
14	12	3.5	6	6	2 x M3 x 0.5 x 4	44	-	51	25	38	1	1.6	31	0.02	0.04	0.03
17	12.5	3.5	6.5	8	2 x M3 x 0.5 x 6	54	-	61	30	45	1	2	38	0.02	0.05	0.035
20	13.5	3.5	7.5	9	-	62	4 x 1.8+0.1	70	36	53	1.5	2	45	0.025	0.055	0.045
25	17	4.5	10	11	-	77	5 x 2.3+0.1	88	48	66	1.5	2	56	0.03	0.07	0.045
32	22	5.5	14	14	-	100	5 x 2.3+0.1	114	60	86	1.5	2	73	0.04	0.075	0.05

Harmonic Ring - Big Component Set Dimensional Drawings

NOTES

- 1 RECOMMENDED ASSEMBLY TOLERANCE FOR PROPER OPERATION
- 2 RECOMMENDED HOUSING / CASE DIMENSIONS FOR PROPER CLEARANCE AND LUBRICANT RETENTION
- 3 RECOMMENDED MATING FEATURE TOLERANCE
- 4 DATUM INDICATOR MARKS TO BE OUTWARD FACING AT ASSEMBLY
- 5 REFER TO SOLID MODEL FOR FEATURES NOT DEFINED
- 6 HOUSING FEATURES THAT CONTACT THE OD SPLINE MUST HAVE A HARDNESS OF 29 - 34 HRC

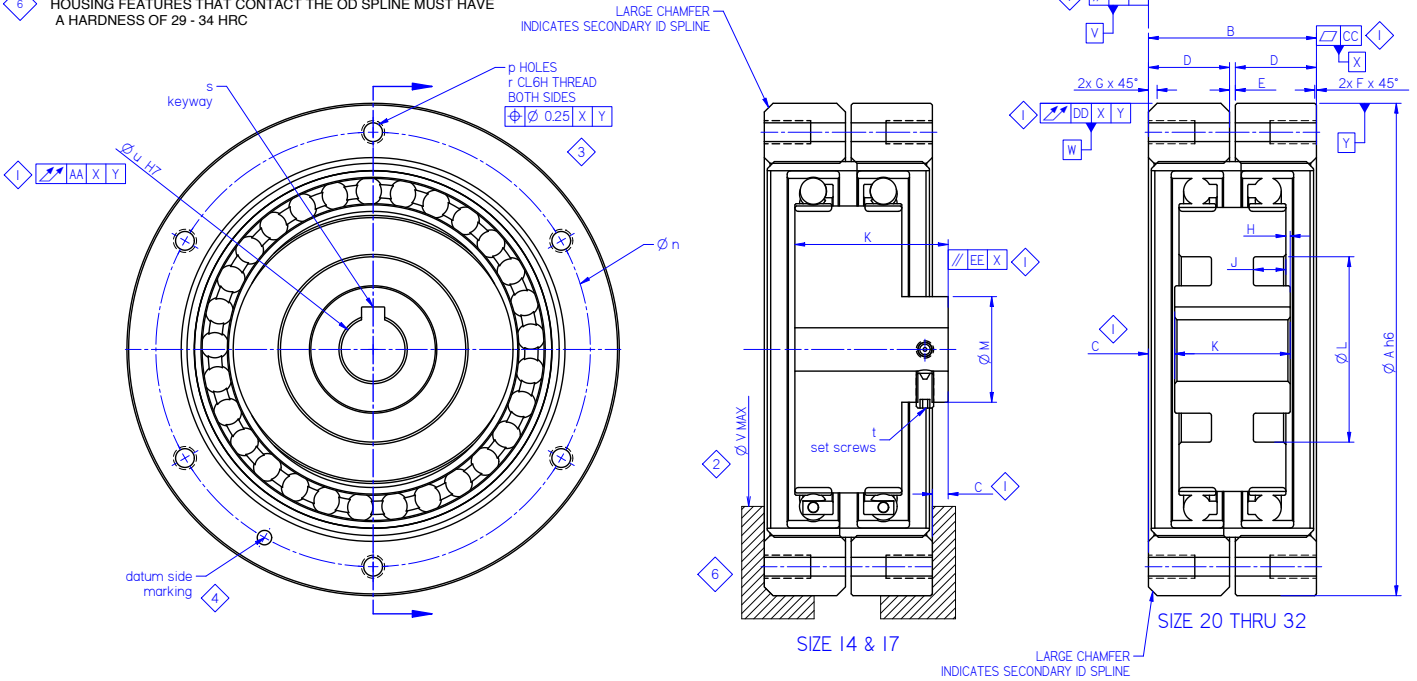

*Solid model available on configurator

Cross hatched pattern indicates housing and is the responsibility of the customer

Size	ØA	B	C	D	E	F	G	H	J	K	ØL	ØM
(all units in mm unless otherwise noted)												
14	50	18	4.25	8.5	1	0.3 x 45°	1 x 45°	-	-	19.9 - 20	-	14
17	60	20	3.8	9.5	1	0.3 x 45°	1 x 45°	-	-	20.9 - 21	-	18
20	70	25	3.85	12	1	0.3 x 45°	1 x 45°	-	-	17.3	-	-
25	85	29	4.5	14	1	0.3 x 45°	1.5 x 45°	1.6	4.8	20	32	22
32	110	37	5.55	18	1	0.3 x 45°	1.5 x 45°	1.9	6.1	25.9	42	28

Size	Øn	p	r	s	t	Øu	ØV	AA	BB	CC	DD	EE
(all units in mm unless otherwise noted)												
14	44	6	M3 x 0.5 ↓ THRU	-	2 x M3 x 0.5 x 4	6	29	0.015	0.02	0.02	0.015	0.03
17	54	6	M3 x 0.5 ↓ THRU	-	2 x M3 x 0.5 x 6	8	35	0.015	0.025	0.025	0.02	0.04
20	60	6	M3 x 0.5 ↓ 6	3 x 1.4+0.1	-	9	42	0.02	0.025	0.025	0.02	0.045
25	75	6	M4 x 0.7 ↓ 8	4 x 1.8+0.1	-	11	53	0.02	0.03	0.03	0.02	0.06
32	100	6	M5 x 0.8 ↓ 10	5 x 2.3+0.1	-	14	69	0.02	0.04	0.04	0.02	0.065

NOTES

- 1 RECOMMENDED ASSEMBLY TOLERANCE FOR PROPER OPERATION
- 2 RECOMMENDED HOUSING / CASE DIMENSIONS FOR PROPER CLEARANCE AND LUBRICANT RETENTION
- 3 RECOMMENDED MATING FEATURE TOLERANCE
- 4 DATUM INDICATOR MARKS TO BE OUTWARD FACING AT ASSEMBLY
- 5 REFER TO SOLID MODEL FOR FEATURES NOT DEFINED
- 6 HOUSING FEATURES THAT CONTACT THE OD SPLINE MUST HAVE A HARDNESS OF 29 - 34 HRC

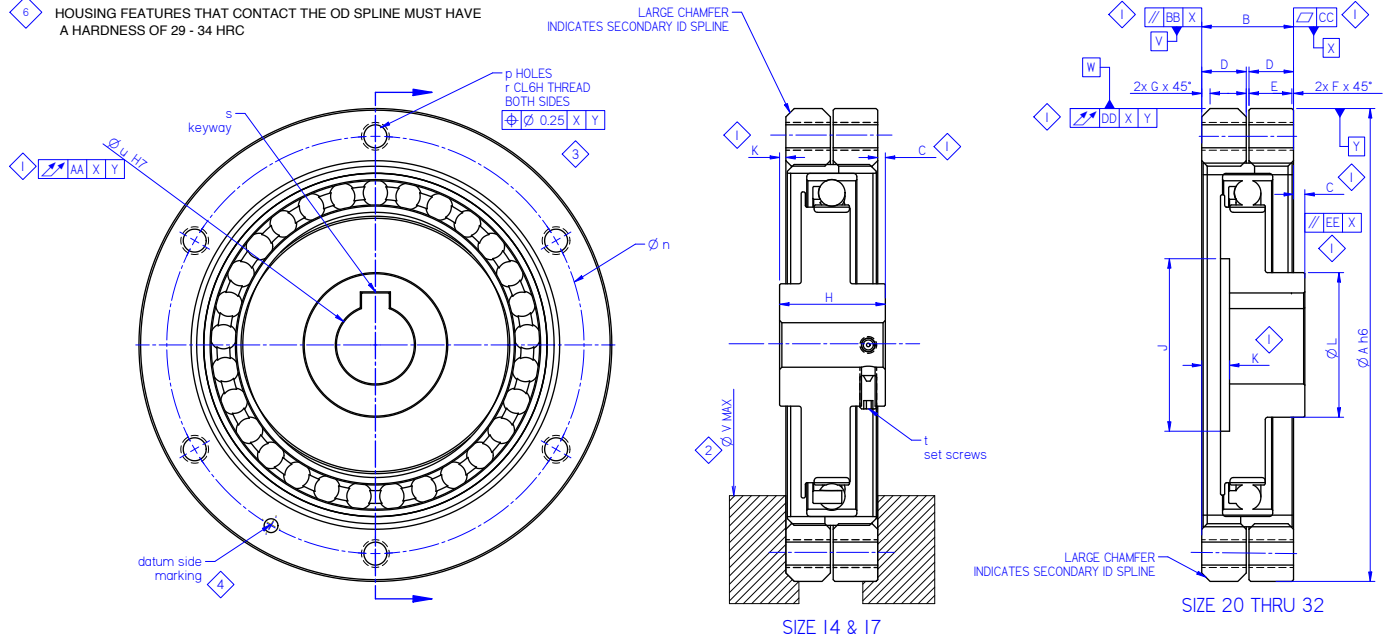

*Solid model available on configurator

Cross hatched pattern indicates housing and is the responsibility of the customer

Size	ØA	B	C	D	E	F	G	H	ØJ	K	ØL
(all units in mm unless otherwise noted)											
14	50	10.5	3.75	5	0.5	0.3 x 45°	1 x 45°	15	-	0.75	14
17	60	11.5	3.8	5.5	0.5	0.3 x 45°	1 x 45°	15.7	-	0.35	18
20	70	12.5	0.95	6	0.5	0.3 x 45°	1 x 45°	11.4	31.5	2.05	20
25	85	16.5	-0.35	8	0.5	0.3 x 45°	1.5 x 45°	12.8	41	3.35	26
32	110	20.5	-0.95	10	0.5	0.3 x 45°	1.5 x 45°	15.6	52	3.95	26

Size	Øn	p	r	s	t	Øu	ØV	AA	BB	CC	DD	EE
(all units in mm unless otherwise noted)												
14	44	6	M3 x 0.5 ↓ THRU	-	2 x M3 x 0.5 x 4	6	29	0.015	0.02	0.02	0.015	0.03
17	54	6	M3 x 0.5 ↓ THRU	-	2 x M3 x 0.5 x 6	8	35	0.015	0.025	0.025	0.02	0.04
20	60	6	M4 x 0.7 ↓ THRU	3 x 1.4+0.1	-	9	42	0.02	0.025	0.025	0.02	0.045
25	75	6	M5 x 0.8 ↓ THRU	5 x 2.3+0.1	-	14	53	0.02	0.03	0.03	0.02	0.06
32	100	6	M6 x 1 ↓ THRU	5 x 2.3+0.1	-	14	69	0.02	0.04	0.04	0.02	0.065

CONTINUOUS TORQUE

Torque at which the unit can operate continuously for L10 life. Rating is at 2,000RPM input speed.

START - STOP TORQUE

Max torque at which the unit can operate in a start - stop (acceleration - deceleration) application.

MAX AVERAGE TORQUE

For applications where the unit runs at different torque loads over its life. This is the max average torque over its life. All torques must be less than peak torque rating.

PEAK TORQUE

Torque at which the unit can operate for 5,000 input revolutions. This is the highest load the unit should see expecting it to still be operational. An E-stop condition is a good example.

EFFICIENCY

The efficiency of a harmonic unit is dependent on the reduction ratio, input speed, load torque, and lubricant type and quantity. The lubricant type and quantity may impact the gearbox efficiency in respect to temperature. Published efficiency is at the following operating conditions:

INPUT SPEED	2000 RPM
AMBIENT TEMPERATURE	20°C (68°F)
LUBRICANT	Cone Drive Harmonic Solutions® High Performance L1 Grease
LUBRICANT QUANTITY	Standard Quantity

NO LOAD INPUT TORQUE

No load running torque is the torque required to spin the high speed input shaft when the low speed output is unloaded. The no load running torque can be affected by reduction ratio, input speed, and lubricant type and quantity. Published no load input torque is at the following operating conditions:

INPUT SPEED	2000 RPM
AMBIENT TEMPERATURE	20°C (68°F)
LUBRICANT	Cone Drive Harmonic Solutions® High Performance L1 Grease
LUBRICANT QUANTITY	Standard Quantity

STARTING TORQUE

Torque required to start motion of the input with no load applied at the output. Standard grease lubrication at standard temperature 20°C.

BACKDRIVE STARTING TORQUE

Torque required to turn output with a freely rotating input. (no load attached to input side). Standard grease lubrication at standard temperature 20°C.

DRIVETRAIN INERTIA AT INPUT

The tendency of a drivetrain to resist change in rotation velocity. All components in motion add to this resistance of change. In standard configurations these rotating components include: Input, OD Spline, bearings, assembly bolts, other minor components.

MAX BACKLASH

Backlash occurs in a harmonic unit that utilizes an Oldham input and is due to the internal clearance of the Oldham coupling. This is in addition to the Hysteresis loss and is dependent on the size and ratio of the unit. This parameter does not apply to solid wave generator inputs.

HYSTERESIS LOSS

Hysteresis loss is the lost motion that occurs due to internal friction of all harmonic gearboxes. When a harmonic unit is loaded to a torque and the load is returned to zero load or the load is reversed, the output position of the harmonic reducer will not return zero. The published hysteresis loss is that which occurs when the unit is operated at the Continuous Rated Torque and may be reduced at torque levels below rated torque.

TORSIONAL STIFFNESS (K1, K2, K3)

The torsional stiffness of a harmonic unit is an important parameter that impacts that stiffness of a complete motion control system. The torsional stiffness is defined as the displacement of the low speed output shaft when the high speed input shaft is locked and a torque is applied to the output shaft. The torsional stiffness curve is represented with three best fit slopes, hysteresis loss and backlash (if applicable).

TRANSMISSION ERROR

The deviation of the expected output position and the actual output position when rotating the input.

TORSIONAL STIFFNESS CURVE

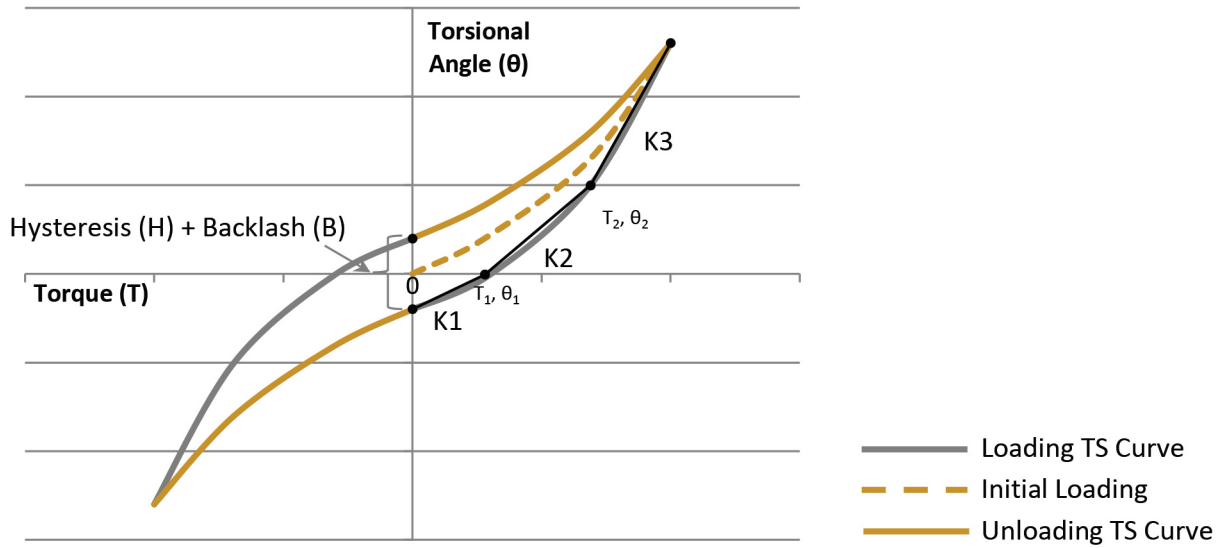

TORSIONAL STIFFNESS FORMULAS

$$T \leq T_1: \quad \theta = \frac{T}{K_1} - \frac{(H^* + B)}{2}$$

$$T_1 < T \leq T_2: \quad \theta = \frac{T_1}{K_1} + \frac{(T - T_1)}{K_2} - \frac{(H^* + B)}{2}$$

$$T > T_2: \quad \theta = \frac{T_1}{K_1} + \frac{(T_2 - T_1)}{K_2} + \frac{(T - T_2)}{K_3} - \frac{(H^* + B)}{2}$$

* At loads less than Continuous Rated Torque, the lost motion due to hysteresis loss may be less than specified.

POSITIONAL ACCURACY & VIBRATION

Positional accuracy is defined as the difference between the actual output angular position and the theoretical output angular position based upon the input angular position and ratio. This error is termed the transmission error (θ_{TE}) of the gearbox and is measured in milliradians (mRad) or arcseconds.

$$\theta_{TE} = \theta_{Output} - \frac{\theta_{Input}}{Ratio}$$

θ_{TE}	Angular Transmission Error
θ_{Input}	Input Angular Position
θ_{Output}	Output Angular Position
$Ratio$	Reduction Ratio of Gearbox (1:Ratio)

1 mRad = 206.27 arcsecond

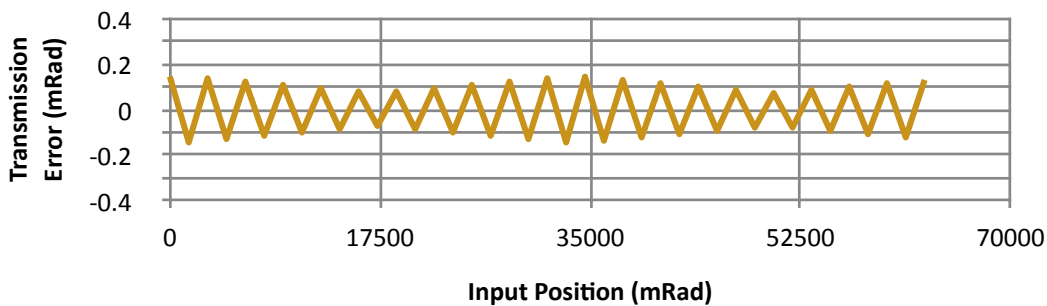

The primary frequency of the transmission error is twice that of the input speed (i.e. period is twice per input revolution). This characteristic along with the natural frequency of the system can be used to determine the input speed at which a system may resonate; a source of system vibration.

Equations for the natural frequency of a harmonic system and approximate speed at which a resonance may occur can be found from the following equations:

$$f_n = \frac{1}{2\pi} \sqrt{\frac{K * 1000}{I}}$$

$$N_{Resonant} = \frac{60f_n}{2}$$

f_n	Natural Frequency (Hz)
K	Torsional Stiffness at Load Point (Nm/mRad)
I	Output Inertia (kgm ²)
$N_{Resonant}$	Resonant Input speed (RPM)

Size	Ratio	Continuous Torque Rating (2000 rpm)	Start/Stop Torque Rating	Max Average Torque Rating	Peak Torque Rating	Efficiency (2000 rpm, 20°C, Continuous Rated Load)	No Load Input Torque (2000 rpm at 20°C)	Starting Torque (20°C)	Backdrive Starting Torque (20°C)	Transmission Error	Hysteresis	Max Backlash
		Nm	Nm	Nm	Nm	%	Nm	Nm	Nm	mRad	mRad	mRad
CUP COMPONENT SET (CBC)												
11	50	3.4	7.8	5.1	16.6	72	0.024	0.016	1.0	0.57	0.58	0.14
11	100	4.8	10.6	8.4	25.5	71	0.021	0.011	1.4	0.44	0.58	0.073
14	50	7.6	24.4	8.8	44	72	0.040	0.036	1.5	0.44	0.58	0.18
14	80	10.3	30	13.9	58	74	0.036	0.026	1.5	0.44	0.29	0.11
14	100	10.2	32	13.3	63	68	0.035	0.023	1.9	0.44	0.29	0.087
17	50	21.5	43	34	88	74	0.069	0.056	2.8	0.44	0.58	0.097
17	80	28.6	53	34	107	72	0.062	0.036	2.8	0.44	0.29	0.063
17	100	29.8	64	51	133	75	0.061	0.032	3.1	0.44	0.29	0.048
17	120	29.2	65	51	113	69	0.060	0.030	3.4	0.44	0.29	0.039
20	50	32	72	43	127	73	0.11	0.073	4.4	0.29	0.58	0.082
20	80	42	94	61	156	75	0.10	0.045	4.6	0.29	0.29	0.053
20	100	51	100	62	185	72	0.10	0.041	5.0	0.29	0.29	0.044
20	120	50	105	62	184	72	0.098	0.036	5.4	0.29	0.29	0.039
20	160	50	114	62	182	66	0.096	0.032	6.4	0.29	0.29	0.029
25	50	49	124	70	230	73	0.22	0.13	8.3	0.29	0.58	0.082
25	80	74	177	112	307	76	0.20	0.085	8.5	0.29	0.29	0.053
25	100	82	185	137	346	71	0.20	0.076	9.2	0.29	0.29	0.044
25	120	83	191	136	346	73	0.19	0.069	10.0	0.29	0.29	0.039
25	160	80	202	131	356	66	0.19	0.061	12.1	0.29	0.29	0.029
32	50	99	274	139	480	73	0.45	0.29	18.0	0.29	0.58	0.068
32	80	153	341	212	726	75	0.41	0.18	18.0	0.29	0.29	0.044
32	100	170	403	278	824	72	0.41	0.17	20.0	0.29	0.29	0.034
32	120	171	430	275	823	72	0.40	0.14	21.0	0.29	0.29	0.029
32	160	172	460	275	751	66	0.40	0.13	25.0	0.29	0.29	0.024
CUP GEARHEAD (CBG)												
11	50	3.4	7.8	5.1	16.6	64	0.030	0.020	1.2	0.57	0.58	0.14
11	100	4.8	10.6	8.4	25.5	64	0.024	0.013	1.5	0.44	0.58	0.073
14	50	7.6	24.4	8.8	44	64	0.053	0.045	1.8	0.44	0.58	0.18
14	80	10.3	30	13.9	58	65	0.044	0.031	1.8	0.44	0.29	0.11
14	100	10.2	32	13.3	63	63	0.042	0.028	2.0	0.44	0.29	0.087
17	50	21.5	43	34	88	71	0.089	0.066	3.3	0.44	0.58	0.097
17	80	28.6	53	34	107	72	0.076	0.044	3.3	0.44	0.29	0.063
17	100	29.8	64	51	133	72	0.073	0.037	3.6	0.44	0.29	0.048
17	120	29.2	65	51	113	69	0.071	0.034	3.9	0.44	0.29	0.039
20	50	32	72	43	127	71	0.13	0.086	5.2	0.29	0.58	0.082
20	80	42	94	61	156	72	0.11	0.054	5.3	0.29	0.29	0.053
20	100	51	100	62	185	72	0.11	0.047	5.6	0.29	0.29	0.044
20	120	50	105	62	184	70	0.11	0.042	6.1	0.29	0.29	0.039
20	160	50	114	62	182	65	0.10	0.036	6.9	0.29	0.29	0.029
25	50	49	124	70	230	71	0.25	0.17	10.0	0.29	0.58	0.082
25	80	74	177	112	307	73	0.22	0.10	10.0	0.29	0.29	0.053
25	100	82	185	137	346	72	0.21	0.088	11.0	0.29	0.29	0.044
25	120	83	191	136	346	70	0.21	0.080	11.9	0.29	0.29	0.039
25	160	80	202	131	356	65	0.20	0.069	14.2	0.29	0.29	0.029
32	50	99	274	139	480	71	0.52	0.34	20.0	0.29	0.58	0.068
32	80	153	341	212	726	72	0.46	0.21	21.0	0.29	0.29	0.044
32	100	170	403	278	824	72	0.45	0.20	22.0	0.29	0.29	0.034
32	120	171	430	275	823	70	0.44	0.17	24.0	0.29	0.29	0.029
32	160	172	460	275	751	65	0.42	0.15	29.0	0.29	0.29	0.024

Size	Ratio	T1	T2	K1	K2	K3	Mass	Unit Ix Inertia about C.G.	Unit Iy=Iz Inertia about C.G.	Drive-train Inertia at input	Output Bearing Pitch Dia (dp)	Output Bearing Face Offset (w)	Basic Dynamic Output Bearing Load Rating (C)	Basic Static Output Bearing Load Rating (Co)	Max Output Bearing Moment Load	Output Bearing Moment Rigidity	Max Wave Generator Bore	Max Wave Generator Shaft
		Nm	Nm	Nm/mRad	Nm/mRad	Nm/mRad	kg	x10-6 kg-m2	x10-6 kg-m2	x10-6 kg-m2	mm	mm	kN	kN	Nm	Nm/mRad	mm	mm
CUP COMPONENT SET (CBC)																		
11	50	0.80	2.0	2.2	3.0	3.2	0.059	9.8	6.1	1.2	-	-	-	-	-	-	14.1	16.0
11	100	0.80	2.0	2.7	3.4	4.4	0.059	9.8	6.1	1.2	-	-	-	-	-	-	0.0	0.0
14	50	2.0	6.9	3.4	4.7	5.7	0.11	28.7	17.3	3.9	-	-	-	-	-	-	18.6	22.0
14	80	2.0	6.9	4.7	6.1	7.1	0.11	28.7	17.3	3.9	-	-	-	-	-	-	0.0	0.0
14	100	2.0	6.9	4.7	6.1	7.1	0.11	28.7	17.3	3.9	-	-	-	-	-	-	0.0	0.0
17	50	3.9	12.1	8.1	11.1	12.9	0.18	65	39	9.6	-	-	-	-	-	-	23.8	28.0
17	80	3.9	12.1	10.0	14.1	15.9	0.18	65	39	9.6	-	-	-	-	-	-	0.0	0.0
17	100	3.9	12.1	10.0	14.1	15.9	0.18	65	39	9.6	-	-	-	-	-	-	0.0	0.0
17	120	3.9	12.1	10.0	14.1	15.9	0.18	65	39	9.6	-	-	-	-	-	-	0.0	0.0
20	50	7.0	25.0	13.0	18.0	23.0	0.21	133	74	23.0	-	-	-	-	-	-	26.6	32
20	80	7.0	25.0	16.0	25.0	29.0	0.21	133	74	23.0	-	-	-	-	-	-	0.0	0.0
20	100	7.0	25.0	16.0	25.0	29.0	0.21	133	74	23.0	-	-	-	-	-	-	0.0	0.0
20	120	7.0	25.0	16.0	25.0	29.0	0.21	133	74	23.0	-	-	-	-	-	-	0.0	0.0
20	160	7.0	25.0	16.0	25.0	29.0	0.21	133	74	23.0	-	-	-	-	-	-	0.0	0.0
25	50	14.0	48	25.0	34	44	0.45	368	207	58	-	-	-	-	-	-	34	42
25	80	14.0	48	31	50	57	0.45	368	207	58	-	-	-	-	-	-	0.0	0.0
25	100	14.0	48	31	50	57	0.45	368	207	58	-	-	-	-	-	-	0.0	0.0
25	120	14.0	48	31	50	57	0.45	368	207	58	-	-	-	-	-	-	0.0	0.0
25	160	14.0	48	31	50	57	0.45	368	207	58	-	-	-	-	-	-	0.0	0.0
32	50	29.0	108	54	78	98	0.95	1415	771	176	-	-	-	-	-	-	45	56
32	80	29.0	108	67	110	120	0.95	1415	771	176	-	-	-	-	-	-	0.0	0.0
32	100	29.0	108	67	110	120	0.95	1415	771	176	-	-	-	-	-	-	0.0	0.0
32	120	29.0	108	67	110	120	0.95	1415	771	176	-	-	-	-	-	-	0.0	0.0
32	160	29.0	108	67	110	120	0.95	1415	771	176	-	-	-	-	-	-	0.0	0.0
CUP GEARHEAD (CBG)																		
11	50	0.80	2.0	2.2	3.0	3.2	0.40	162	113	1.2	27.0	8.5	4.8	5.2	13.0	26.0	14.1	16.0
11	100	0.80	2.0	2.7	3.4	4.4	0.40	162	113	1.2	27.0	8.5	4.8	5.2	13.0	26.0	0.0	0.0
14	50	2.0	6.9	3.4	4.7	5.7	0.54	275	196	3.9	35	9.5	5.6	6.5	18.0	40	18.6	22.0
14	80	2.0	6.9	4.7	6.1	7.1	0.54	275	196	3.9	35	9.5	5.6	6.5	18.0	40	0.0	0.0
14	100	2.0	6.9	4.7	6.1	7.1	0.54	275	196	3.9	35	9.5	5.6	6.5	18.0	40	0.0	0.0
17	50	3.9	12.1	8.1	11.1	12.9	0.72	448	322	9.6	43	9.5	6.3	8.1	28.0	78	23.8	28.0
17	80	3.9	12.1	10.0	14.1	15.9	0.72	448	322	9.6	43	9.5	6.3	8.1	28.0	78	0.0	0.0
17	100	3.9	12.1	10.0	14.1	15.9	0.72	448	322	9.6	43	9.5	6.3	8.1	28.0	78	0.0	0.0
17	120	3.9	12.1	10.0	14.1	15.9	0.72	448	322	9.6	43	9.5	6.3	8.1	28.0	78	0.0	0.0
20	50	7.0	25.0	13.0	18.0	23.0	1.0	875	582	22.7	50	9.5	6.6	9.2	40	140	26.6	32
20	80	7.0	25.0	16.0	25.0	29.0	1.0	875	582	22.7	50	9.5	6.6	9.2	40	140	0.0	0.0
20	100	7.0	25.0	16.0	25.0	29.0	1.0	875	582	22.7	50	9.5	6.6	9.2	40	140	0.0	0.0
20	120	7.0	25.0	16.0	25.0	29.0	1.0	875	582	22.7	50	9.5	6.6	9.2	40	140	0.0	0.0
20	160	7.0	25.0	16.0	25.0	29.0	1.0	875	582	22.7	50	9.5	6.6	9.2	40	140	0.0	0.0
25	50	14.0	48	25.0	34	44	1.6	1851	1259	57	62	11.5	10.9	15.3	82	260	34	42
25	80	14.0	48	31	50	57	1.6	1851	1259	57	62	11.5	10.9	15.3	82	260	0.0	0.0
25	100	14.0	48	31	50	57	1.6	1851	1259	57	62	11.5	10.9	15.3	82	260	0.0	0.0
25	120	14.0	48	31	50	57	1.6	1851	1259	57	62	11.5	10.9	15.3	82	260	0.0	0.0
25	160	14.0	48	31	50	57	1.6	1851	1259	57	62	11.5	10.9	15.3	82	260	0.0	0.0
32	50	29.0	108	54	78	98	3.3	6691	4421	176	80	13.0	18.0	27.5	191	620	45	56
32	80	29.0	108	67	110	120	3.3	6691	4421	176	80	13.0	18.0	27.5	191	620	0.0	0.0
32	100	29.0	108	67	110	120	3.3	6691	4421	176	80	13.0	18.0	27.5	191	620	0.0	0.0
32	120	29.0	108	67	110	120	3.3	6691	4421	176	80	13.0	18.0	27.5	191	620	0.0	0.0
32	160	29.0	108	67	110	120	3.3	6691	4421	176	80	13.0	18.0	27.5	191	620	0.0	0.0

Size	Ratio	Continuous Torque Rating (2000 rpm)	Start/Stop Torque Rating	Max Average Torque Rating	Peak Torque Rating	Efficiency (2000 rpm, 20°C, Continuous Rated Load)	No Load Input Torque (2000 rpm at 20°C)	Starting Torque (20°C)	Backdrive Starting Torque (20°C)	Transmission Error	Hysteresis	Max Backlash
		Nm	Nm	Nm	Nm	%	Nm	Nm	Nm	mRad	mRad	mRad
HAT COMPONENT SET (HBC)												
14	50	7.6	24.4	8.8	44	71	0.036	0.037	2.2	0.44	0.58	0.18
14	80	10.3	30	13.9	58	71	0.032	0.028	2.7	0.44	0.29	0.11
14	100	10.2	32	13.3	63	68	0.031	0.024	2.8	0.44	0.29	0.087
17	50	21.5	43	34	88	78	0.069	0.058	3.4	0.44	0.58	0.097
17	80	28.6	53	34	107	77	0.062	0.038	3.7	0.44	0.29	0.063
17	100	29.8	64	51	133	77	0.060	0.033	4.0	0.44	0.29	0.048
17	120	29.2	65	51	113	74	0.059	0.031	4.5	0.44	0.29	0.039
20	50	32	72	43	127	78	0.11	0.073	4.4	0.29	0.58	0.082
20	80	42	94	61	156	77	0.098	0.048	4.6	0.29	0.29	0.053
20	100	51	100	62	185	77	0.095	0.043	5.2	0.29	0.29	0.044
20	120	50	105	62	184	74	0.094	0.039	5.6	0.29	0.29	0.039
20	160	50	114	62	182	70	0.091	0.034	6.6	0.29	0.29	0.029
25	50	49	124	70	230	78	0.21	0.14	8.2	0.29	0.58	0.082
25	80	74	177	112	307	77	0.19	0.089	8.6	0.29	0.29	0.053
25	100	82	185	137	346	77	0.18	0.079	9.5	0.29	0.29	0.044
25	120	83	191	136	346	74	0.18	0.073	10.0	0.29	0.29	0.039
25	160	80	202	131	356	70	0.17	0.064	12.1	0.29	0.29	0.029
32	50	99	274	139	480	78	0.43	0.28	17.0	0.29	0.58	0.068
32	80	153	341	212	726	77	0.39	0.19	18.0	0.29	0.29	0.044
32	100	170	403	278	824	77	0.38	0.18	21.0	0.29	0.29	0.034
32	120	171	430	275	823	74	0.38	0.15	21.0	0.29	0.29	0.029
32	160	172	460	275	751	70	0.37	0.14	26.0	0.29	0.29	0.024
HAT GEARHEAD (HBC)												
14	50	7.6	24.4	8.8	44	64	0.057	0.052	3.1	0.44	0.58	0.18
14	80	10.3	30	13.9	58	65	0.050	0.040	3.8	0.44	0.29	0.11
14	100	10.2	32	13.3	63	61	0.048	0.034	4.1	0.44	0.29	0.087
17	50	21.5	43	34	88	67	0.12	0.087	5.2	0.44	0.58	0.097
17	80	28.6	53	34	107	66	0.11	0.063	6.1	0.44	0.29	0.063
17	100	29.8	64	51	133	65	0.11	0.057	6.8	0.44	0.29	0.048
17	120	29.2	65	51	113	62	0.10	0.054	7.8	0.44	0.29	0.039
20	50	32	72	43	127	68	0.18	0.12	7.4	0.29	0.58	0.082
20	80	42	94	61	156	69	0.16	0.095	8.7	0.29	0.29	0.053
20	100	51	100	62	185	65	0.16	0.085	10.3	0.29	0.29	0.044
20	120	50	105	62	184	64	0.15	0.080	11.2	0.29	0.29	0.039
20	160	50	114	62	182	58	0.15	0.073	14.2	0.29	0.29	0.029
25	50	49	124	70	230	69	0.29	0.20	11.9	0.29	0.58	0.082
25	80	74	177	112	307	71	0.26	0.14	13.4	0.29	0.29	0.053
25	100	82	185	137	346	66	0.25	0.13	15.1	0.29	0.29	0.044
25	120	83	191	136	346	66	0.25	0.12	16.6	0.29	0.29	0.039
25	160	80	202	131	356	59	0.24	0.11	20.6	0.29	0.29	0.029
32	50	99	274	139	480	70	0.55	0.38	23.0	0.29	0.58	0.068
32	80	153	341	212	726	70	0.50	0.26	25.5	0.29	0.29	0.044
32	100	170	403	278	824	69	0.48	0.25	30	0.29	0.29	0.034
32	120	171	430	275	823	68	0.47	0.22	31	0.29	0.29	0.029
32	160	172	460	275	751	62	0.46	0.21	39	0.29	0.29	0.024

Size	Ratio	T1	T2	K1	K2	K3	Mass	Unit Ix Inertia about C.G.	Unit Iy=Iz Inertia about C.G.	Drive-train Inertia at input	Output Bearing Pitch Dia (dp)	Output Bearing Face Offset (w)	Basic Dynamic Output Bearing Load Rating (C)	Basic Static Output Bearing Load Rating (Co)	Max Output Bearing Moment Load	Output Bearing Moment Rigidity	Max Wave Generator Bore	Max Wave Generator Shaft
		Nm	Nm	Nm/mRad	Nm/mRad	Nm/mRad	kg	x10-6 kg-m2	x10-6 kg-m2	x10-6 kg-m2	mm	mm	kN	kN	Nm	Nm/mRad	mm	mm
HAT COMPONENT SET (HBC)																		
14	50	2.0	6.9	3.4	4.7	5.7	0.13	43	29.1	3.9	-	-	-	-	-	-	18.6	22.0
14	80	2.0	6.9	4.7	6.1	7.1	0.13	43	29.1	3.9	-	-	-	-	-	-	0.0	0.0
14	100	2.0	6.9	4.7	6.1	7.1	0.13	43	29.1	3.9	-	-	-	-	-	-	0.0	0.0
17	50	3.9	12.1	8.1	11.1	12.9	0.20	97	64	9.6	-	-	-	-	-	-	23.8	28.0
17	80	3.9	12.1	10.0	14.1	15.9	0.20	97	64	9.6	-	-	-	-	-	-	0.0	0.0
17	100	3.9	12.1	10.0	14.1	15.9	0.20	97	64	9.6	-	-	-	-	-	-	0.0	0.0
17	120	3.9	12.1	10.0	14.1	15.9	0.20	97	64	9.6	-	-	-	-	-	-	0.0	0.0
20	50	7.0	25.0	13.0	18.0	23.0	0.28	189	121	23.0	-	-	-	-	-	-	26.6	32
20	80	7.0	25.0	16.0	25.0	29.0	0.28	189	121	23.0	-	-	-	-	-	-	0.0	0.0
20	100	7.0	25.0	16.0	25.0	29.0	0.28	189	121	23.0	-	-	-	-	-	-	0.0	0.0
20	120	7.0	25.0	16.0	25.0	29.0	0.28	189	121	23.0	-	-	-	-	-	-	0.0	0.0
20	160	7.0	25.0	16.0	25.0	29.0	0.28	189	121	23.0	-	-	-	-	-	-	0.0	0.0
25	50	14.0	48	25.0	34	44	0.44	514	313	58	-	-	-	-	-	-	34	42
25	80	14.0	48	31	50	57	0.44	514	313	58	-	-	-	-	-	-	0.0	0.0
25	100	14.0	48	31	50	57	0.44	514	313	58	-	-	-	-	-	-	0.0	0.0
25	120	14.0	48	31	50	57	0.44	514	313	58	-	-	-	-	-	-	0.0	0.0
25	160	14.0	48	31	50	57	0.44	514	313	58	-	-	-	-	-	-	0.0	0.0
32	50	29.0	108	54	78	98	0.94	1832	1059	176	-	-	-	-	-	-	45	56
32	80	29.0	108	67	110	120	0.94	1832	1059	176	-	-	-	-	-	-	0.0	0.0
32	100	29.0	108	67	110	120	0.94	1832	1059	176	-	-	-	-	-	-	0.0	0.0
32	120	29.0	108	67	110	120	0.94	1832	1059	176	-	-	-	-	-	-	0.0	0.0
32	160	29.0	108	67	110	120	0.94	1832	1059	176	-	-	-	-	-	-	0.0	0.0
HAT GEARHEAD (HBC)																		
14	50	2.0	6.9	3.4	4.7	5.7	0.41	273	153	4.0	50	9.6	6.6	9.3	40	140	18.6	22.0
14	80	2.0	6.9	4.7	6.1	7.1	0.41	273	153	4.0	50	9.6	6.6	9.3	40	140	0.0	0.0
14	100	2.0	6.9	4.7	6.1	7.1	0.41	273	153	4.0	50	9.6	6.6	9.3	40	140	0.0	0.0
17	50	3.9	12.1	8.1	11.1	12.9	0.59	517	289	9.8	61	10.0	10.5	14.7	77	240	23.8	28.0
17	80	3.9	12.1	10.0	14.1	15.9	0.59	517	289	9.7	61	10.0	10.5	14.7	77	240	0.0	0.0
17	100	3.9	12.1	10.0	14.1	15.9	0.59	517	289	9.6	61	10.0	10.5	14.7	77	240	0.0	0.0
17	120	3.9	12.1	10.0	14.1	15.9	0.59	517	289	9.6	61	10.0	10.5	14.7	77	240	0.0	0.0
20	50	7.0	25.0	13.0	18.0	23.0	0.81	904	503	23.2	70	10.5	16.3	22.9	138	380	26.6	32
20	80	7.0	25.0	16.0	25.0	29.0	0.81	904	503	23.1	70	10.5	16.3	22.9	138	380	0.0	0.0
20	100	7.0	25.0	16.0	25.0	29.0	0.81	904	503	23.0	70	10.5	16.3	22.9	138	380	0.0	0.0
20	120	7.0	25.0	16.0	25.0	29.0	0.81	904	503	23.0	70	10.5	16.3	22.9	138	380	0.0	0.0
20	160	7.0	25.0	16.0	25.0	29.0	0.81	904	503	23.0	70	10.5	16.3	22.9	138	380	0.0	0.0
25	50	14.0	48	25.0	34	44	1.3	2191	1205	58	85	11.7	20.3	33	249	870	34	42
25	80	14.0	48	31	50	57	1.3	2191	1205	58	85	11.7	20.3	33	249	870	0.0	0.0
25	100	14.0	48	31	50	57	1.3	2191	1205	58	85	11.7	20.3	33	249	870	0.0	0.0
25	120	14.0	48	31	50	57	1.3	2191	1205	58	85	11.7	20.3	33	249	870	0.0	0.0
25	160	14.0	48	31	50	57	1.3	2191	1205	58	85	11.7	20.3	33	249	870	0.0	0.0
32	50	29.0	108	54	78	98	2.7	7700	4190	178	111	14.9	43	68	661	1825	45	56
32	80	29.0	108	67	110	120	2.7	7700	4190	177	111	14.9	43	68	661	1825	0.0	0.0
32	100	29.0	108	67	110	120	2.7	7700	4190	177	111	14.9	43	68	661	1825	0.0	0.0
32	120	29.0	108	67	110	120	2.7	7700	4190	176	111	14.9	43	68	661	1825	0.0	0.0
32	160	29.0	108	67	110	120	2.7	7700	4190	176	111	14.9	43	68	661	1825	0.0	0.0

Size	Ratio	Continuous Torque Rating (2000 rpm)	Start/Stop Torque Rating	Max Average Torque Rating	Peak Torque Rating	Efficiency (2000 rpm, 20°C, Continuous Rated Load)	No Load Input Torque (2000 rpm at 20°C)	Starting Torque (20°C)	Backdrive Starting Torque (20°C)	Transmission Error	Hysteresis	Max Backlash
		Nm	Nm	Nm	Nm	%	Nm	Nm	Nm	mRad	mRad	mRad
LITTLE RING COMPONENT SET (RLC)												
14	50	3.0	5.0	5.0	11.0	55	0.040	0.023	0.023	0.59	1.6	0.88
14	80	4.1	6.7	6.7	14.6	55	0.036	0.010	0.010	0.59	1.6	0.88
14	100	4.1	6.7	6.7	15.9	52	0.035	0.007	0.007	0.59	1.6	0.88
17	50	8.5	13.0	13.0	22.0	55	0.069	0.028	0.028	0.59	1.6	0.88
17	80	11.4	17.2	17.2	26.7	54	0.062	0.012	0.012	0.59	1.6	0.88
17	100	11.8	17.9	17.9	33	52	0.061	0.009	0.009	0.59	1.6	0.88
17	120	11.6	17.6	17.6	28.1	49	0.060	0.007	0.007	0.59	1.6	0.88
20	50	12.9	20.7	20.7	32	55	0.11	0.026	0.026	0.38	1.6	0.88
20	80	16.6	26.6	26.6	39	55	0.10	0.014	0.014	0.38	1.6	0.88
20	100	20.1	32	32	46	52	0.10	0.011	0.011	0.38	1.6	0.88
20	120	20.0	32	32	46	49	0.098	0.009	0.009	0.38	1.6	0.88
20	160	19.9	32	32	46	44	0.096	0.007	0.007	0.38	1.6	0.88
25	50	19.6	29.9	29.9	58	55	0.22	0.056	0.056	0.38	1.7	0.88
25	80	29.3	45	45	77	55	0.20	0.028	0.028	0.38	1.7	0.88
25	100	33	50	50	86	52	0.20	0.023	0.023	0.38	1.7	0.88
25	120	33	51	51	87	49	0.19	0.019	0.019	0.38	1.7	0.88
25	160	32	48	48	89	44	0.19	0.015	0.015	0.38	1.7	0.88
32	50	39	63	63	106	55	0.45	0.11	0.11	0.38	1.7	0.88
32	80	61	97	97	160	55	0.41	0.049	0.049	0.38	1.7	0.88
32	100	67	108	108	181	52	0.41	0.039	0.039	0.38	1.7	0.88
32	120	68	108	108	181	49	0.40	0.030	0.030	0.38	1.7	0.88
32	160	68	109	109	165	44	0.40	0.020	0.020	0.38	1.7	0.88
BIG RING COMPONENT SET (RBC)												
14	50	6.0	9.6	9.6	17.7	60	0.072	0.039	0.039	0.59	0.81	0.43
14	80	8.2	13.1	13.1	23.3	59	0.064	0.011	0.011	0.59	0.81	0.43
14	100	8.1	13.0	13.0	25.4	57	0.063	0.005	0.005	0.59	0.81	0.43
17	50	17.1	24.8	24.8	35	60	0.12	0.056	0.056	0.59	0.81	0.43
17	80	22.7	33	33	43	60	0.11	0.015	0.015	0.59	0.81	0.43
17	100	23.6	34	34	53	56	0.11	0.007	0.007	0.59	0.81	0.43
17	120	23.2	34	34	45	54	0.11	0.001	0.001	0.59	0.81	0.43
20	50	25.8	34	34	57	60	0.20	0.058	0.058	0.38	0.81	0.43
20	80	33	44	44	70	59	0.18	0.021	0.021	0.38	0.81	0.43
20	100	40	53	53	83	57	0.18	0.014	0.014	0.38	0.81	0.43
20	120	40	53	53	83	53	0.18	0.009	0.009	0.38	0.81	0.43
20	160	40	53	53	82	47	0.17	0.002	0.002	0.38	0.81	0.43
25	50	39	56	56	104	60	0.39	0.20	0.20	0.38	0.82	0.43
25	80	59	84	84	138	59	0.36	0.076	0.076	0.38	0.82	0.43
25	100	65	94	94	156	57	0.35	0.053	0.053	0.38	0.82	0.43
25	120	66	95	95	156	53	0.35	0.036	0.036	0.38	0.82	0.43
25	160	63	91	91	160	47	0.34	0.015	0.015	0.38	0.82	0.43
32	50	78	115	115	192	60	0.81	0.27	0.27	0.38	0.82	0.43
32	80	122	179	179	290	59	0.75	0.11	0.11	0.38	0.82	0.43
32	100	135	198	198	330	57	0.73	0.081	0.081	0.38	0.82	0.43
32	120	135	199	199	329	53	0.72	0.059	0.059	0.38	0.82	0.43
32	160	136	200	200	300	47	0.71	0.032	0.032	0.38	0.82	0.43

Size	Ratio	T1	T2	K1	K2	K3	Mass	Unit Ix Inertia about C.G.	Unit Iy=Iz Inertia about C.G.	Drive-train Inertia at input	Output Bearing Pitch Dia (dp)	Output Bearing Face Offset (w)	Basic Dynamic Output Bearing Load Rating (C)	Basic Static Output Bearing Load Rating (Co)	Max Output Bearing Moment Load	Output Bearing Moment Rigidity	Max Wave Generator Bore	Max Wave Generator Shaft
		Nm	Nm	Nm/mRad	Nm/mRad	Nm/mRad	kg	x10-6 kg-m2	x10-6 kg-m2	x10-6 kg-m2	mm	mm	kN	kN	Nm	Nm/mRad	mm	mm
LITTLE RING COMPONENT SET (RLC)																		
14	50	0.39	12.3	0.44	5.0	-	0.13	41	21.7	3.4	-	-	-	-	-	-	18.6	22.0
14	80	0.39	12.3	0.44	5.0	-	0.13	41	21.7	3.4	-	-	-	-	-	-	0.0	0.0
14	100	0.39	12.3	0.44	5.0	-	0.13	41	21.7	3.4	-	-	-	-	-	-	0.0	0.0
17	50	0.70	24.5	0.79	10.0	-	0.19	92	48	7.9	-	-	-	-	-	-	23.8	28.0
17	80	0.70	24.5	0.79	10.0	-	0.19	92	48	7.9	-	-	-	-	-	-	0.0	0.0
17	100	0.70	24.5	0.79	10.0	-	0.19	92	48	7.8	-	-	-	-	-	-	0.0	0.0
17	120	0.70	24.5	0.79	10.0	-	0.19	92	48	7.8	-	-	-	-	-	-	0.0	0.0
20	50	1.2	36	1.3	15.0	-	0.27	186	96	16.5	-	-	-	-	-	-	26.6	32
20	80	1.2	36	1.3	15.0	-	0.27	186	96	16.5	-	-	-	-	-	-	0.0	0.0
20	100	1.2	36	1.3	15.0	-	0.27	186	96	16.5	-	-	-	-	-	-	0.0	0.0
20	120	1.2	36	1.3	15.0	-	0.27	186	96	16.5	-	-	-	-	-	-	0.0	0.0
20	160	1.2	36	1.3	15.0	-	0.27	186	96	16.5	-	-	-	-	-	-	0.0	0.0
25	50	2.3	70	2.5	35	-	0.48	507	262	48	-	-	-	-	-	-	34	42
25	80	2.3	70	2.5	35	-	0.48	507	262	48	-	-	-	-	-	-	0.0	0.0
25	100	2.3	70	2.5	35	-	0.48	507	262	48	-	-	-	-	-	-	0.0	0.0
25	120	2.3	70	2.5	35	-	0.48	507	262	48	-	-	-	-	-	-	0.0	0.0
25	160	2.3	70	2.5	35	-	0.48	507	262	48	-	-	-	-	-	-	0.0	0.0
32	50	4.5	156	5.1	73	-	1.0	1817	936	158	-	-	-	-	-	-	45	56
32	80	4.5	156	5.1	73	-	1.0	1817	936	158	-	-	-	-	-	-	0.0	0.0
32	100	4.5	156	5.1	73	-	1.0	1817	936	158	-	-	-	-	-	-	0.0	0.0
32	120	4.5	156	5.1	73	-	1.0	1817	936	157	-	-	-	-	-	-	0.0	0.0
32	160	4.5	156	5.1	73	-	1.0	1817	936	157	-	-	-	-	-	-	0.0	0.0
BIG RING COMPONENT SET (RBC)																		
14	50	0.39	12.3	0.90	10.1	-	0.22	71	41	6.2	-	-	-	-	-	-	18.6	22.0
14	80	0.39	12.3	0.90	10.1	-	0.22	71	41	6.2	-	-	-	-	-	-	0.0	0.0
14	100	0.39	12.3	0.90	10.1	-	0.22	71	41	6.2	-	-	-	-	-	-	0.0	0.0
17	50	0.70	24.5	1.6	20.3	-	0.34	163	92	14.5	-	-	-	-	-	-	23.8	28.0
17	80	0.70	24.5	1.6	20.3	-	0.34	163	92	14.4	-	-	-	-	-	-	0.0	0.0
17	100	0.70	24.5	1.6	20.3	-	0.34	163	92	14.4	-	-	-	-	-	-	0.0	0.0
17	120	0.70	24.5	1.6	20.3	-	0.34	163	92	14.4	-	-	-	-	-	-	0.0	0.0
20	50	1.2	36	2.7	30	-	0.55	378	213	33	-	-	-	-	-	-	26.6	32
20	80	1.2	36	2.7	30	-	0.55	378	213	33	-	-	-	-	-	-	0.0	0.0
20	100	1.2	36	2.7	30	-	0.55	378	213	33	-	-	-	-	-	-	0.0	0.0
20	120	1.2	36	2.7	30	-	0.55	378	213	33	-	-	-	-	-	-	0.0	0.0
20	160	1.2	36	2.7	30	-	0.55	378	213	33	-	-	-	-	-	-	0.0	0.0
25	50	2.3	70	5.2	70	-	0.87	920	508	96	-	-	-	-	-	-	34	42
25	80	2.3	70	5.2	70	-	0.87	920	508	96	-	-	-	-	-	-	0.0	0.0
25	100	2.3	70	5.2	70	-	0.87	920	508	96	-	-	-	-	-	-	0.0	0.0
25	120	2.3	70	5.2	70	-	0.87	920	508	96	-	-	-	-	-	-	0.0	0.0
25	160	2.3	70	5.2	70	-	0.87	920	508	96	-	-	-	-	-	-	0.0	0.0
32	50	4.5	156	10.4	149	-	1.9	3340	1839	292	-	-	-	-	-	-	45	56
32	80	4.5	156	10.4	149	-	1.9	3340	1839	291	-	-	-	-	-	-	0.0	0.0
32	100	4.5	156	10.4	149	-	1.9	3340	1839	291	-	-	-	-	-	-	0.0	0.0
32	120	4.5	156	10.4	149	-	1.9	3340	1839	291	-	-	-	-	-	-	0.0	0.0
32	160	4.5	156	10.4	149	-	1.9	3340	1839	291	-	-	-	-	-	-	0.0	0.0

COMPONENT SELECTION PROCEDURE

Use the following equations to calculate the required ratings and select a gearbox for your application.
(contact ae@conedrive.com or visit www.conetools.com for further assistance with drive selection)

Calculate Required Weighted Average Output Torque

Calculate the average applied output torque (T_{o_ave}).
Select a unit where T_{o_ave} is less than the rated average value of the unit.

$$T_{o_ave} = \sqrt[3]{\frac{n_{o_1} \times t_1 \times |T_{o_1}|^3 + n_{o_2} \times t_2 \times |T_{o_2}|^3 + \dots + n_{o_n} \times t_n \times |T_{o_n}|^3}{n_{o_1} \times t_1 + n_{o_2} \times t_2 + \dots + n_{o_n} \times t_n}}$$

Calculate Required Average Output Speed

Calculate the required average output speed (n_{o_ave}).

$$n_{o_ave} = \frac{n_{o_1} \times t_1 + n_{o_2} \times t_2 + \dots + n_{o_n} \times t_n}{t_1 + t_2 + \dots + t_n}$$

Calculate Required Average Input Speed

Calculate the required average input speed (n_{i_ave}).

$$n_{i_ave} = n_{o_ave} \times R$$

Verify Required Continuous Output Torque to Rated Torque

Calculate the minimum required continuous output torque ($T_{o_cont_rated_min}$), based on the rated life (L_{10}).
Verify calculated $T_{o_cont_rated_min}$ does not exceed the rated value of the unit ($T_{o_cont_rated}$).

$$T_{o_cont_rated_min} \geq T_{o_ave} \times \sqrt[3]{\left(\frac{L_{10_required}}{L_{10_rated}}\right) \times \left(\frac{n_{i_ave}}{n_{i_cont_rated}}\right)}$$

$$T_{o_cont_rated_min} \leq T_{o_cont_rated}$$

Verify Required Maximum Input Speed to Rated Maximum Speed

Verify input speed does not exceed the rated value of the unit ($n_{i_max_rated}$).

$$n_{i_max} \leq n_{i_max_rated}$$

Verify Weighted Average Output Torque to Rated Torque

Verify output torque does not exceed the rated average value of the unit ($T_{o_ave_rated}$).

$$T_{o_ave} \leq T_{o_ave_rated}$$

CONTINUED ON NEXT PAGE 

COMPONENT SELECTION PROCEDURE (continued)

Verify Required Start/Stop Torque to Rated Start/Stop Torque

Verify start/stop torque does not exceed the rated value of the unit ($T_{o_StartStop_rated}$).

$$T_{o_StartStop} \leq T_{o_StartStop_rated}$$

Verify Required Peak Torque to Rated Peak Torque

Verify peak torque does not exceed the rated value of the unit ($T_{o_Peak_rated}$).

$$T_{o_Peak} \leq T_{o_Peak_rated}$$

Calculate the Number of Allowable Peak Torque Events

Calculate number of allowable peak torque events (N_{peak}) using the output speed at peak output torque (n_{o_peak}).

$$N_{peak} = \frac{10,000}{2 \times \frac{n_{o_peak} \times R}{60} \times t_{peak}}$$

Verify Required Peak Torque Events to Rated Peak Torque Events

Using the calculated allowable peak torque events, verify the selected model is sufficient for the application.

$$N_{peak} \geq N_{peak_required}$$

Calculate the Life of the Unit

Calculate the life of the unit.

$$L_{10_actual} = L_{10_rated} \times \left(\frac{T_{o_cont_rated}}{T_{o_ave}} \right)^3 \times \left(\frac{n_{i_cont_rated}}{n_{i_ave}} \right)$$

Verify Required Life to Predicted Life

Verify the lifetime of the selected model is sufficient for the application.

$$L_{10_actual} \geq L_{10_required}$$

Component Set Selection Procedure complete. If building a gearhead, please proceed to the Output Bearing Selection Procedure.

OUTPUT BEARING CALCULATIONS

(reference Figures 1 through 4 on pages 38 & 39)

If selecting a gearhead (versus component set), the output bearing calculations must be performed in addition to the Component Selection Procedure.

(contact ae@conedrive.com or visit www.conetools.com for further assistance with drive selection)

Calculate and Verify Peak Output Bearing Moment Load

Calculate the peak output moment load (M_{o_peak}) using the output radial loads.

$$M_{Rated} \geq M_{o_peak} = \frac{F_{r_peak} \times (L_r + B) + F_{a_peak} \times L_a}{1000}$$

Verify rated output moment load (M_{Rated}) for the selected units exceeds calculated peak value.

Determine Safety Factor and Calculate Equivalent Radial Output Bearing Load

Calculate the static equivalent radial load (P_o).

$$P_o = X \times \left(F_{r_peak} + \frac{2000 \times M_{o_peak}}{d_p} \right) + Y \times F_{a_peak}$$

Determine the static safety factor (SF_s) by dividing the basic static output bearing load rating (C_o) by the static equivalent radial load (P_o).

$$SF_s = \frac{C_o}{P_o}$$

Review the load conditions below.

Load Conditions	SF_s
Normal Load	≥ 1.5
Impact Load	≥ 2
Enhanced Service Life or Dynamic Performance	≥ 7

Calculate Output Bearing Weighted Average Radial and Axial Loads

Calculate the output bearing average radial load (F_{r_ave}) and average axial load (F_{a_ave}) using the output radial load at step "n" (F_{r_n}).

$$F_{r_ave} = \sqrt[10/3]{\frac{n_{o_1} \times t_1 \times |F_{r_1}|^{10/3} + n_{o_2} \times t_2 \times |F_{r_2}|^{10/3} + \dots + n_{o_n} \times t_n \times |F_{r_n}|^{10/3}}{n_{o_1} \times t_1 + n_{o_2} \times t_2 + \dots + n_{o_n} \times t_n}}$$

$$F_{a_ave} = \sqrt[10/3]{\frac{n_{o_1} \times t_1 \times |F_{a_1}|^{10/3} + n_{o_2} \times t_2 \times |F_{a_2}|^{10/3} + \dots + n_{o_n} \times t_n \times |F_{a_n}|^{10/3}}{n_{o_1} \times t_1 + n_{o_2} \times t_2 + \dots + n_{o_n} \times t_n}}$$

CONTINUED ON NEXT PAGE →

OUTPUT BEARING CALCULATIONS (continued)

(reference Figures 1 through 4 on pages 38 & 39)

Calculate the Average Output Speed

Calculate the average output speed (n_{o_ave}) for the application.

$$n_{o_ave} = \frac{n_{o_1} \times t_1 + n_{o_2} \times t_2 + \dots + n_{o_n} \times t_n}{t_1 + t_2 + \dots + t_n}$$

Calculate the Average Output Moment Load

Calculate the average output moment load (M_{o_ave}) using the load classifications values presented below.

$$M_{o_ave} = \frac{F_{r_ave} \times (L_r + B) + F_{a_ave} \times L_a}{1000}$$

Load Classification	X	Y
$\frac{F_{a_ave}}{F_{r_ave} + \frac{2000 \times M_{o_ave}}{d_p}} \leq 1.5$	1	0.45
$\frac{F_{a_ave}}{F_{r_ave} + \frac{2000 \times M_{o_ave}}{d_p}} > 1.5$	0.67	0.67

Note: If $F_{r_ave} = 0$ and $M_{o_ave} = 0$, use $X = 0.67$ and $Y = 0.67$

Calculate Output Bearing Dynamic Equivalent Radial Load

Calculate the dynamic equivalent radial load (P_d).

$$P_d = X \times \left(F_{r_ave} + \frac{2000 \times M_{o_ave}}{d_p} \right) + Y \times F_{a_ave}$$

Calculate Output Bearing Life – Rotary Motion

Calculate Output Bearing Life – Oscillatory Motion

Calculate the output bearing life (L_{10_output}) for either rotary motion OR oscillatory motion depending on application.

$$L_{10_output} = \frac{10^6}{n_{o_ave} \times 60} \times \left(\frac{C}{f_w \times P_d} \right)^{\frac{10}{3}}$$

$$L_{10_output} = \frac{360 \times 10^6}{2 \times \theta \times N_r \times 60} \times \left(\frac{C}{f_w \times P_d} \right)^{\frac{10}{3}}$$

Service Conditions	f_w
Smooth Motion without Impact	1 to 1.2
Normal Motion	1.2 to 1.5
Excessive Vibration or Impact	1.5 to 3

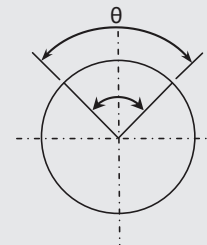

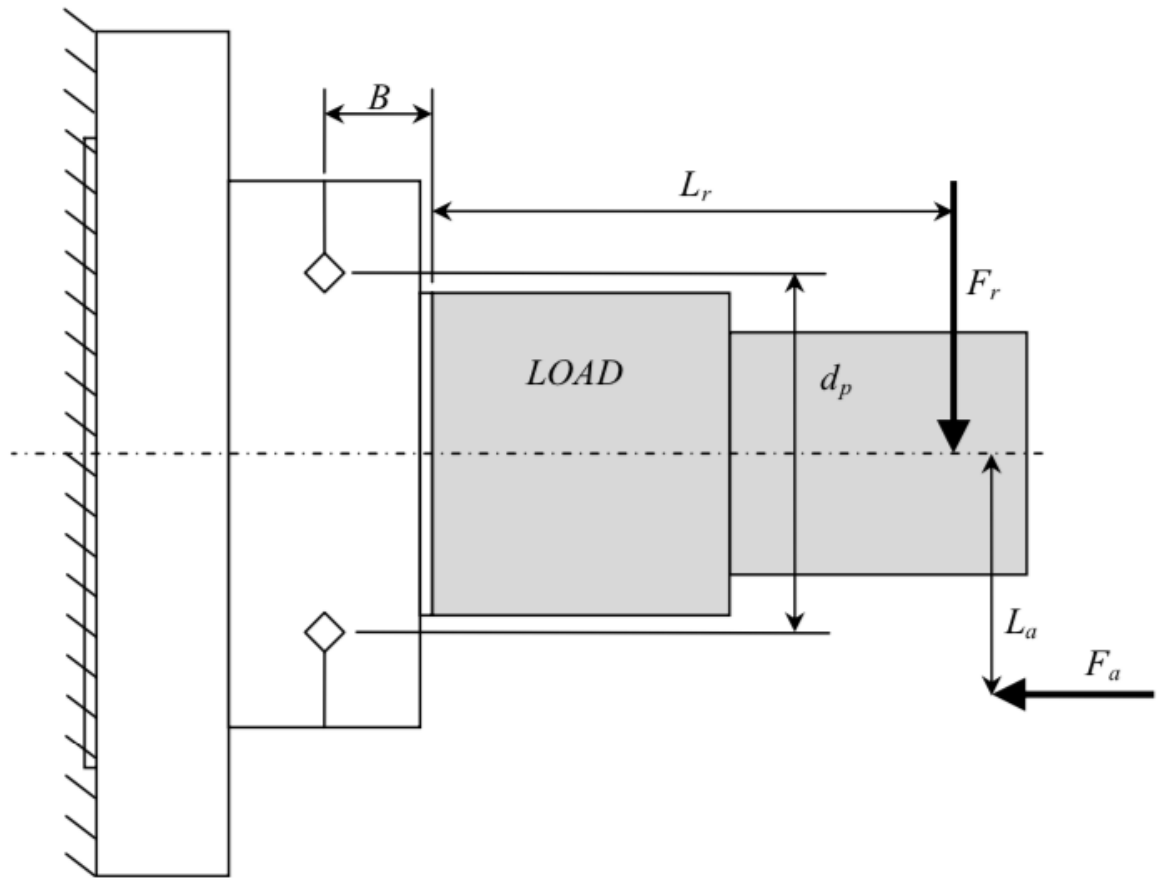

Figure 1. Output Bearing Load Diagram

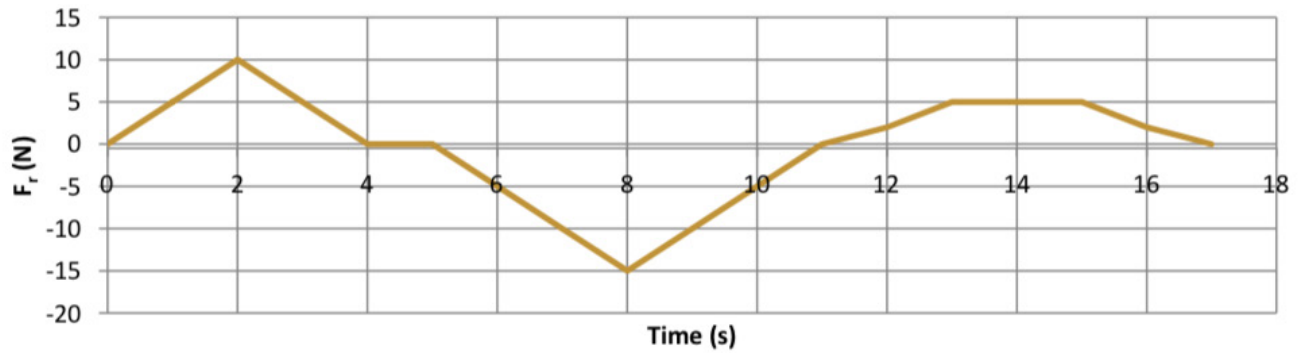

Figure 2. Example Output Radial Load Diagram

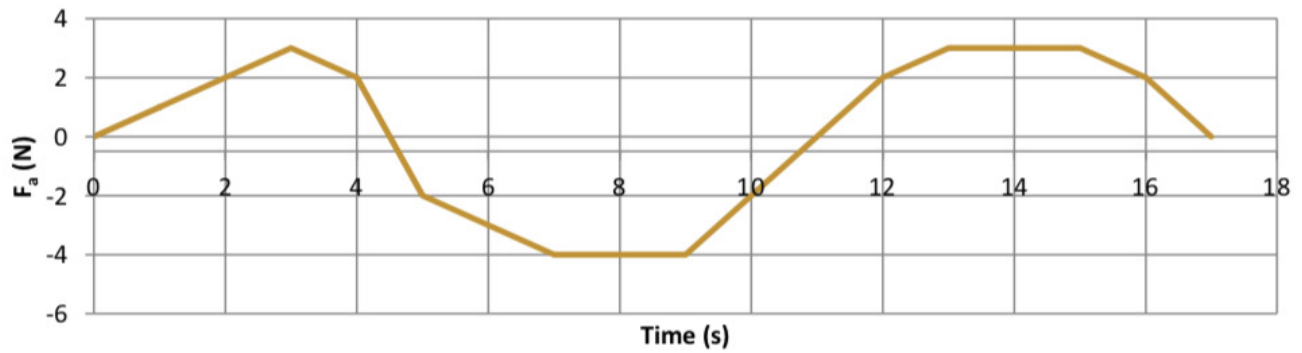

Figure 3. Example Output Axial Load Diagram

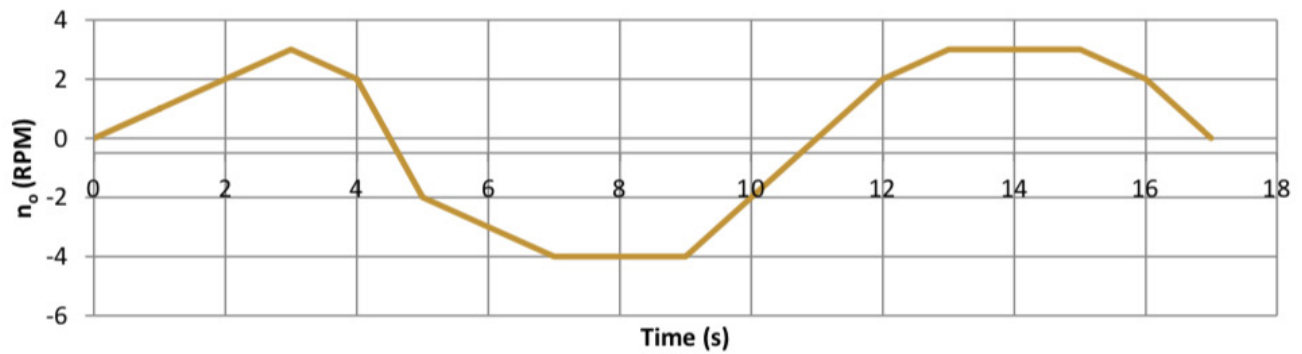

Figure 4. Example Output Speed Diagram

Variable	Units	Description
T_o	Nm	Output Torque
$T_{o,n}$	Nm	Output Torque at step "n" (1,2...n)
$T_{o_cont_rated}$	Nm	Rated Continuous Output Torque
$T_{o_cont_rated_min}$	Nm	Minimum Required Rated Continuous Output Torque
T_{o_ave}	Nm	Average Output Torque
$T_{o_ave_rated}$	Nm	Rated Average Output Torque
$T_{o_StartStop}$	Nm	Start / Stop Output Torque
$T_{o_StartStop_rated}$	Nm	Rated Start / Stop Output Torque
T_{o_Peak}	Nm	Peak Output Torque
$T_{o_Peak_rated}$	Nm	Rated Peak Output Torque
n_o	RPM	Output Speed
$n_{o,n}$	RPM	Output Speed at step "n" (1,2...n)
n_{o_ave}	RPM	Average Output Speed
n_i	RPM	Input Speed
$n_{i,n}$	RPM	Input Speed at step "n" (1,2...n)
$n_{i_cont_rated}$	RPM	Rated Continuous Input Speed
n_{i_ave}	RPM	Average Input Speed
n_{i_max}	RPM	Maximum Input Speed
$n_{i_max_rated}$	RPM	Rated Maximum Input Speed
n_{o_peak}	RPM	Output Speed at T_{o_Peak}
L_{10}	Hours	Input Bearing L_{10} Life (for 90% of Units)
$L_{10_required}$	Hours	Required Input Bearing L_{10} Life
L_{10_rated}	Hours	Rated Input Bearing L_{10} Life
L_{10_actual}	Hours	Predicted Input Bearing L_{10} Life
L_{10_output}	Hours	Output Bearing L_{10} Life
C_{o_peak}	Cycles	Number of Allowable Impact OD Spline Cycles
N_{peak}	Events	Number of Allowable Impact Events
$N_{peak_required}$	Events	Required Impact Events
N_r	Osc/min	Oscillations per Minute
$N_{Resonant}$	RPM	Resonant Input Speed
t	Seconds	Time
t_n	Seconds	Time Duration of step "n" (1,2...n)
t_{peak}	Seconds	Time that T_{o_Peak} is Applied during Impact Event

Variable	Units	Description
R	:1	Ratio
$F_{r,n}$	N	Output Radial Load at step "n" (1,2...n)
$F_{r,ave}$	N	Average Output Radial Load
$F_{r,peak}$	N	Peak Output Radial Load
$F_{a,n}$	N	Output Axial Load at step "n" (1,2...n)
$F_{a,ave}$	N	Average Output Axial Load
$F_{a,peak}$	N	Peak Output Axial Load
$M_{o,n}$	Nm	Output Moment Load at step "n" (1,2...n)
$M_{o,ave}$	Nm	Average Output Moment Load
$M_{o,peak}$	Nm	Peak Output Moment Load
M_{Rated}	Nm	Rated Output Moment Load (see ratings tables)
d_p	mm	Output Bearing Pitch Diameter
X	-	Radial Load Coefficient
Y	-	Axial Load Coefficient
L_r	mm	Distance of Radial Load to Bearing Face
L_a	mm	Distance of Axial Load from Centerline
B	mm	Roller Offset from Bearing Face (see ratings tables)
P_d	N	Dynamic Equivalent Radial Load
P_o	N	Static Equivalent Radial Load
C	N	Basic Dynamic Output Bearing Load Rating
f_w	-	Dynamic Load Coefficient
C_o	N	Basic Static Output Bearing Load Rating
SF_s	-	Static Safety Factor
θ	Deg	Oscillation Angle

Gearhead to Motor Installation (Figures 5 and 6)

• MOTOR ADAPTER

- A motor adapter plate (1) must be made to center the motor shaft to the wave generator assembly (2).
- The adapter plate should slip fit pilot to both the gearhead and the motor.
- O-rings and shaft seals (3) should be used on each mating surface to contain assembly lubrication, and keep contaminants out.
- To insure smooth operation, surfaces and diameters must be precision machined to maintain concentricity and alignment as specified on the assembly drawing.
- Steel or high strength alloy aluminum would be acceptable material choices for the adapter plate. Plastic or non-precision parts will result in poor gearing performance and premature wear or damage to the gearset.

• WAVE GENERATOR ASSEMBLY

- The wave generator assembly must be supported in both the radial and axial direction.
- Axial forces are generated by the gearing. Consult with your motor manufacturer on bearing load capacity and contact Cone Drive if there are concerns of this being an issue.
- The wave generator can be fixed axially to the motor shaft in many ways. One option is to have a tapped hole in the end of the motor shaft, and a screw and washer (4) to retain the assembly on the shaft. Fixing the wave generator in the other direction is a snap ring (5) in a groove on the motor shaft as shown in the view above. Other options are clamp rings, bushings, or even bonding of the surfaces. The goal of any of these methods is to position the wave generator as specified on the Cone Drive drawing. Standard drawings are available on our online configurator program (www.conetools.com) under each model number. For customized parts, contact Cone Drive for the drawing.

• FINAL GEARMOTOR ASSEMBLY

- The most common procedure is to install the motor adapter plate to the motor, followed by the wave generator assembly to the motor. Next, this assembly is installed into the OD spline (flexspline).
- Rotation of the wave generator assembly will aide in installation (when possible).
- Use of excessive force when installing the wave generator may cause permanent damage to the gear teeth or wave generator bearing.
- It may be helpful to slightly loosen the motor mounting or motor adapter bolts while rotating the complete assembly. This will allow parts to self center.
- Concentricity of parts and alignment of components is key to smooth operation.

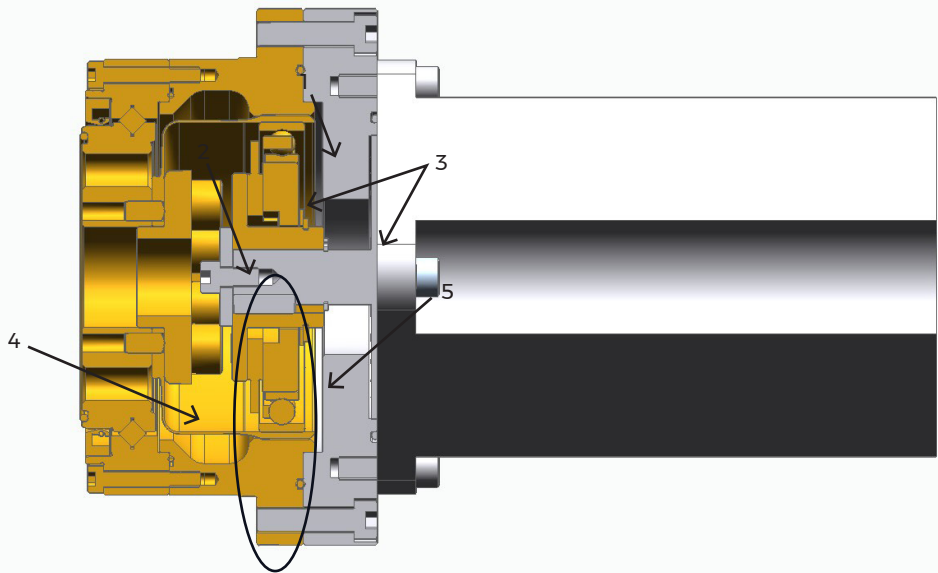

Figure 5. Gearhead to Motor Installation: **Cup Style**

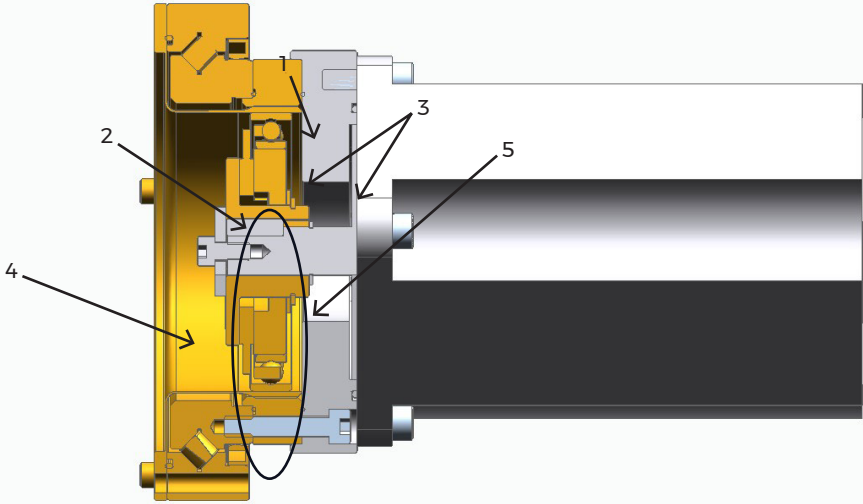

Figure 6. Gearhead to Motor Installation: **Hat Style**

Gold color denotes Cone Drive supplied components

Component Gearset Installation (Figures 7 and 8)

• HOUSING

- A housing must be made to hold the gearset components concentric and within the specified tolerances on the assembly drawing.
- Standard assembly drawings are available on our online configurator program under each model number. For customized parts, contact Cone Drive for the drawing.
- All mating surfaces should use o-rings (1), shaft seals (2), or other means to contain the gearset lubrication and keep contaminants out.
- To insure smooth operation, surfaces and diameters must be precision machined to maintain concentricity and alignment as specified on the assembly drawing.
- Steel or high strength alloy aluminum would be acceptable material choices for the housing. Plastic or non-precision parts will result in poor gearing performance and premature wear or damage to the gearset.

• WAVE GENERATOR ASSEMBLY

- The wave generator assembly must be supported in both the radial and axial direction.
- Axial forces are generated by the gearing. Consult with your motor manufacturer on bearing load capacity and contact Cone Drive if there are concerns of this being an issue.
- The wave generator can be fixed axially to the drive shaft in many ways. One option is to have a tapped hole and washer on the end of the drive shaft, and a snap ring on the opposite end. Another option is to use snap rings on both sides as shown in the view above. Other options are clamp rings, bushings, or even bonding of the surfaces. The goal of any of these methods is to position the wave generator as specified on the Cone Drive drawing.
- For setscrew attachment, be sure to have an access hole (4) in the housing for tightening.

• OD SPLINE

- The OD spline must be fixed in both axial and radial directions. The base of the OD spline serves as the output of the gearing.
- Use of all dowel pin (5) and screw holes (6) is required for full torque capacity. Grade 10.9 or better fasteners must be used in all bolt holes. The OD Spline also has a piloting feature (10) for alignment. Failure to align and keep parts concentric will cause increased wear and vibration. Please consult the product drawing for these critical specifications.
- An output plate (7) must be used to clamp the base of the OD spline to the output bearing of your choice.
- The clamp plate must be designed without sharp edges contacting the OD spline to prevent stress concentrations.

• ID SPLINE

- The ID spline can be piloted to the housing using the outer diameter (8) or the reduced diameter (9) just outside the gear teeth as noted on the assembly drawing.

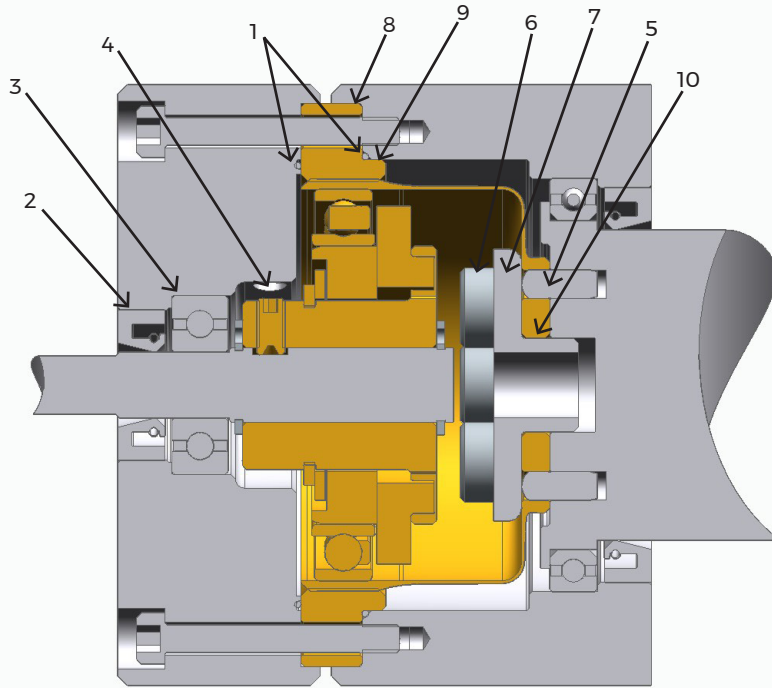

Figure 7. Component Gearset Installation: Cup Style

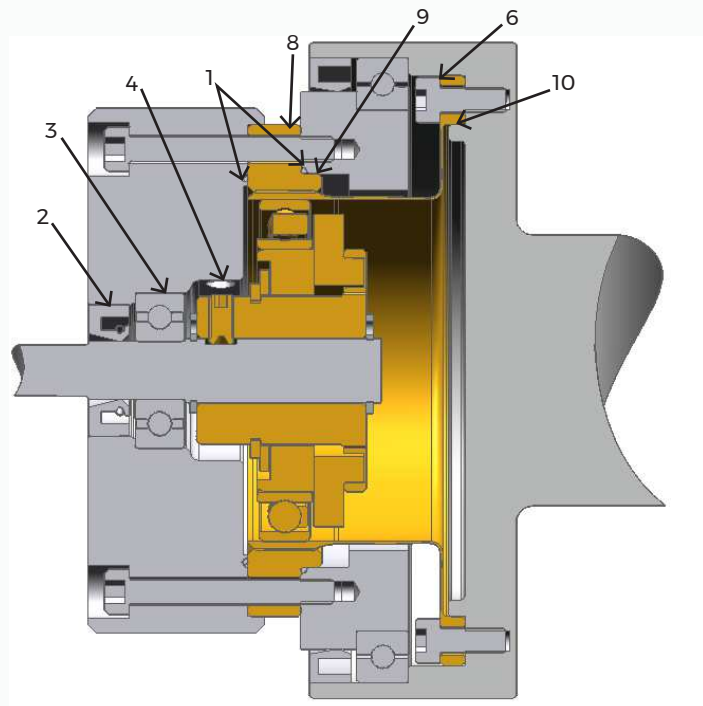
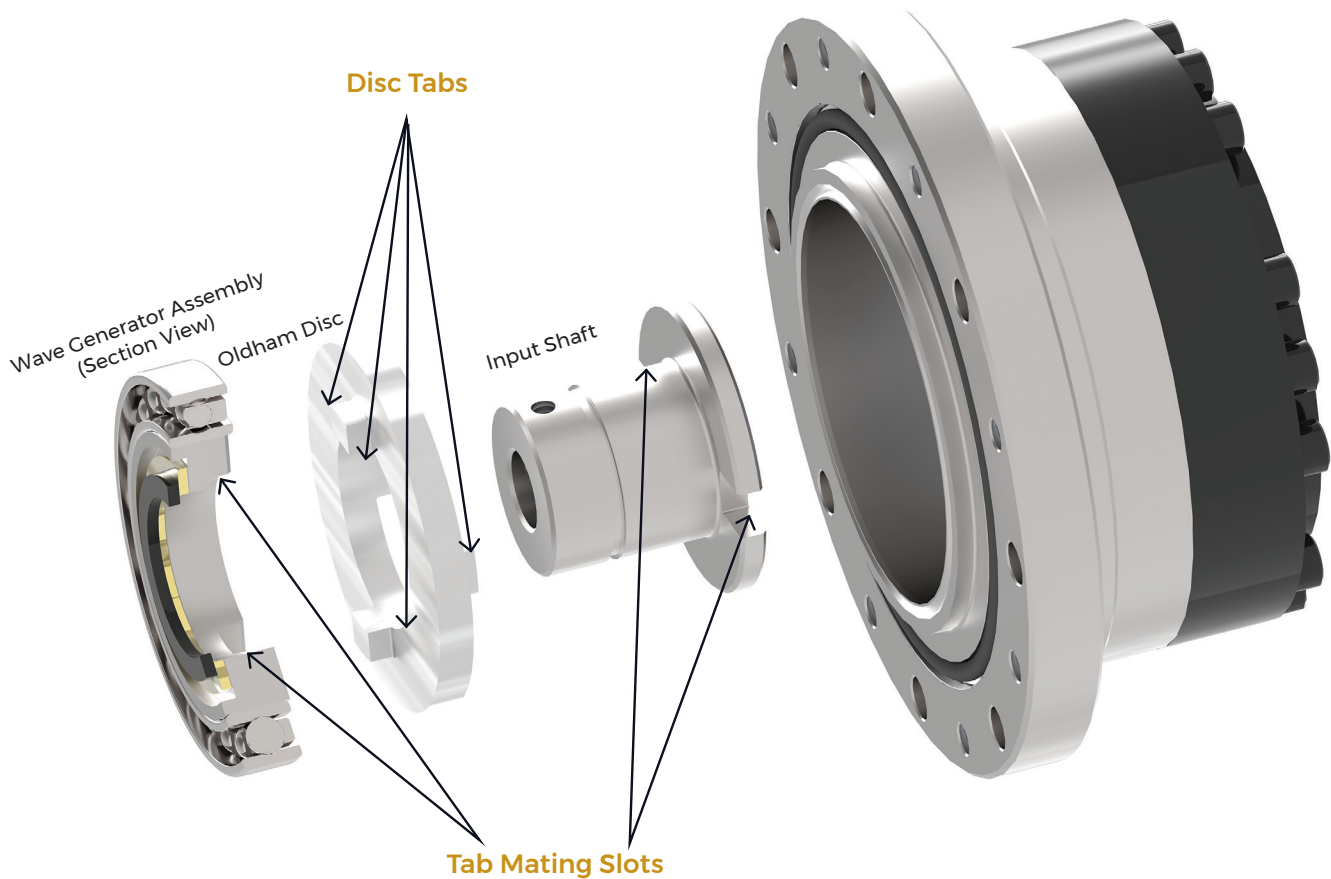

Figure 8. Component Gearset Installation: Hat Style

Gold color denotes Cone Drive supplied components

The Oldham input assembly is a two jaw-type coupling that allows movement in two radial directions. This feature provides added tolerance for drive shaft radial runout.



See page 16 for additional input options.

Benefits for your application

- Low average torque in harmonic gear type drives
- Excellent low temperature performance
- Solid-free additives to enhance protection of friction points subject to high loads

Description

Cone Drive Harmonic Solutions® High Performance L1 Grease is designed for use in harmonic gear type drives such as those found in robots and machine tools.

This specially developed grease consists of synthetic hydrocarbon oil and lithium soap.

Application

Cone Drive Harmonic Solutions® High Performance L1 Grease is used for harmonic gear type drives*. Silicone is not a component of the formulation of this product.

The grease can be applied by grease gun, spatula, brush, or automatic lubricant dispenser. We recommend testing the pumpability of the grease in automatic lubrication systems.

Safety data sheets

The safety data sheet (SDS) for Cone Drive Harmonic Solutions® High Performance L1 Grease is available at www.conedrive.com/resources

Cone Drive Harmonic Solutions® High Performance L1 Grease	
Can	1 kg
Part Number	HSGREASE-01-KG
Base Oil Type	Synthetic
Thickener Type	Lithium
Lower Service Temperature (°C/°F)	-40/-40
Upper Service Temperature (°C/°F)	150/302
Base Oil Viscosity, ASTM D-7042 (40°C)	45 - 55 mm ² /s
Cone Penetration, ASTM D-217	370 - 400
NLGI Grade	0 to 00
Dropping Point, ASTM D-2265 (°C)	180
Oil Separation, DIN 51817 (168h, 40°C)	approx. 8%
Flow Pressure, DIN 51805 (-40°C)	75 mbar
Minimum shelf life if the product is stored in its unopened, original container in a dry, frost-free place, approx.	24 months

*Contact ae@conedrive.com if application requires custom lubrication

HANDLING

- Cone Drive Harmonic Solutions® are machined and assembled in a controlled environment designed to provide cleanliness and thermal stability. The assembly area is based on an ISO Class 8 (or better) Clean Room. Product handling by the user shall make every effort to insure it is handled with care in the same manner, with appropriate measures to avoid contamination from entering the unit.
- Use of ISO Class 5 (or better) Clean Room lint-free gloves is recommended when handling the product.
- Use of ISO Class 5 (or better) Clean Room lint-free cleaning wipes is recommended for cleaning and preparing the product for use.
- Use ethyl or methyl alcohol (or similar) with lint-free cleaning wipes to clean the product, but not an excessive amount to dilute the lubricant. Do not use solvents as these may damage seals, o-rings, and adhesive joints.
- The individual components have been machined to be a matched set. Do not mix components or the warranty will be void. If components are mixed, the life and performance of the product will quickly deteriorate.
- Do not drop the unit, or subject the components to impact of any type. If any component of the product is dropped, impacted, or damaged in any way, it should be considered suspect and should not be used.
- Avoid dust, dirt, chips, or other debris and foreign matter. Refer to the ISO Class 8 (or better) Clean Room requirements.

INSTALLATION REQUIREMENTS

- Refer to the approved lubricant list for the harmonic product line found at www.conedrive.com/resources for lubricants that have been tested and approved for use by Cone Drive. Unapproved lubricants will void the warranty. Contact ae@conedrive.com if application requires custom lubrication.
- Alignment and accuracy of input and output interfaces is critical to the product life and function. Refer to the approval drawing or standard product drawing for alignment and accuracy requirements of interface components and features.
- The standard product is designed for indoor use where the ambient temperature range is 32°F to 100°F, and no water or excess humidity comes in contact with the product. For other ambient environments contact Cone Drive at ae@conedrive.com.
- The standard product must not be used in an explosive or corrosive environment.
- Recommended Break-In Procedure for standard product: After appropriately applying approved lubrication, operate the unit under the following conditions:
 - After installation, rotate the input both clockwise and counterclockwise at 250 RPM for 30 sec and then 1000 RPM for 5 minutes. Maximum operation temperature should not exceed 175°F. If the unit exhibits a sharp increase of operating temperature or the temperature exceeds 175°F, the unit may be damaged and should be inspected.
 - The maximum acceptable input speed is 3000 RPM during the break-in period. Cone Drive recommends a slower input speed during the break-in procedure.
 - Rotate the output as close to, or over one full revolution, before reversing.

MAINTENANCE

- Refer to the approved lubricant list for the harmonic product line found at www.conedrive.com/resources for lubricants that have been tested and approved for use by Cone Drive. Unapproved lubricants will void the warranty.
- Grease – Standard for all models.
 - Grease life will decrease as temperature increases.
 - If using continuously in one direction, grease may be squeezed from the gear mesh. More frequent grease replacement may be required.
 - Grease should be contained in the unit via seals. The grease should be free from any foreign material which could contaminate the grease, or reduce the anti-wear properties.
 - Grease should be changed after the first 100 hours of operation, and every 2000 hours, or 12 months of operation after the first grease change. Actual running torque levels beyond the catalog average torque rating will require more frequent grease changes.
 - It is necessary to mix and/or stir stored grease prior to applying to the gearing to avoid separation of the grease.
- Oil – Optional for component sets and gearhead models shipped without grease.
 - Oil levels are specific for different types; refer to the approval drawing. Oil should be changed after the first 100 hours of operation, and every 2000 hours, or 12 months of operation after the first oil change. Actual running torque levels beyond the catalog average torque rating will require more frequent oil changes.

STORAGE

- The product is shipped in Vapor Corrosion Inhibitor (VCI) polyethylene bags. Do not remove the product from the VCI polyethylene bag until ready for installation.
- The Cone Drive Harmonic Solutions® unit is built to order. Cone Drive recommends using the product as soon as possible in order to avoid grease separation, seal lip material hardening, and/or rust formation. If possible, do not store the unit for more than six months without verifying the product integrity prior to installation into the application. If the unit is suspect, contact Cone Drive at ae@conedrive.com for discussion and possible evaluation of the product.
- If spare units are purchased and stored, Cone Drive recommends using the spare units in a “first in, first out” method in order to use the oldest unit first (rotate unused spares).
- Environmental and/or ambient conditions of storage.
 - 20% to 80% relative humidity (without condensation).
 - Minimal, or no exposure to direct sunlight.
 - Indoor storage, with a temperature and humidity controlled environment is strongly recommended.

SAFETY

- Obtain the appropriate Safety Data Sheet for the lubricant used in the product. Safety Data Sheets are available from the lubricant manufacturer.
- The user is responsible for ensuring the product has the correct guarding and safety measures in place to prevent human injury and/or equipment damage. All individuals involved with the installation and use of this product must use appropriate personal protection safety equipment to prevent human injury.
- The standard product is intended for use in typical industrial applications. Please contact Cone Drive at ae@conedrive.com for applications involving human transport or contact, medical equipment, nuclear equipment, aircraft equipment, space or vacuum equipment or safety related applications.
- Disposal of this product and lubricant should be handled in such a manner that is consistent with local laws and ordinances. The product and lubricant should be considered industrial waste at time of disposal. Metal recycling is encouraged when feasible.

OPERATING CONDITIONS

- Do not exceed the product ratings.
- Refer to the standard product catalog for product life calculations.
- When excessive input torque is applied during operation, the engagement of the teeth between the ID spline and the OD spline may be compromised causing ratcheting. Ratcheting torque information may be obtained from Cone Drive at ae@conedrive.com. If ratcheting occurs, the life and torque capacity will be reduced.
- When excessive output torque and/or overhung loads are applied, permanent damage may occur.

WARRANTY

- Refer to Cone Drive Sales Terms and Conditions found at www.conedrive.com/resources.

Cone Drive reserves the right to improve, or change product design, specifications, and dimensions without notice. The performance of this product can be fully achieved if it is handled, installed, operated, and maintained correctly.



GLOBAL LOCATIONS

NORTH AMERICA | EUROPE | ASIA

