



# SLEWING

## SOLUTIONS

*Cone Drive slewing solutions provide precision motion control for all of your positioning needs. We offer a wide range of solutions to match the loading, environment and precision you require.*

Precision. Motion Control. Technology.











Cone Drive is a world leader in precision motion control technology. We work with our customers every step of the way – from design specs to the final solution – to create highly precise, highly specific products that keep our customers' technology at the forefront of their industry. Cone Drive offers engineering support, unique solutions, and innovative technology across a breadth of markets and products to drive your company forward.



# TABLE OF CONTENTS

## SLEWING SOLUTIONS

<hr/>		
CONFIGURATOR OVERVIEW		2
<hr/>		
CODE DESCRIPTION		4
<hr/>		
PRODUCT CODE COLUMN BREAKDOWN		4
<hr/>		
 W		6
<hr/>		
 WE		8
<hr/>		
 WEA		10
<hr/>		
 S		12
<hr/>		
 SE		14
<hr/>		
 SEA		16
<hr/>		
 HSE		20
<hr/>		
 R		22
<hr/>		
 SLEWING RINGS		24
<hr/>		

Configure your slewing drive online.

ConeTools.com

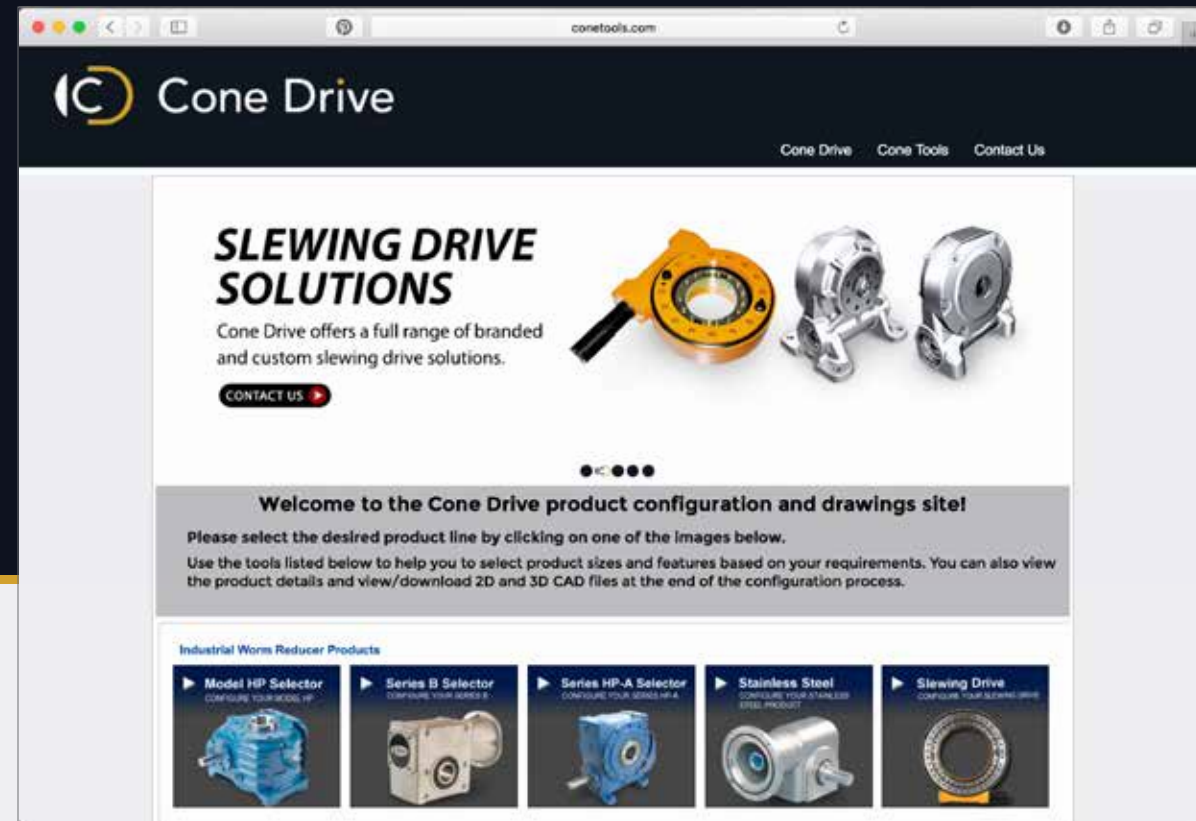

Visit ConeTools.com and Click On "Slewing Drive"



PRODUCT DRAWINGS & MODELS AVAILABLE FOR DOWNLOAD

- ▶ W SERIES
- ▶ WE SERIES
- ▶ WEA SERIES
- ▶ S SERIES
- ▶ SE SERIES
- ▶ SEA SERIES

## SLEW DRIVE CONFIGURATOR

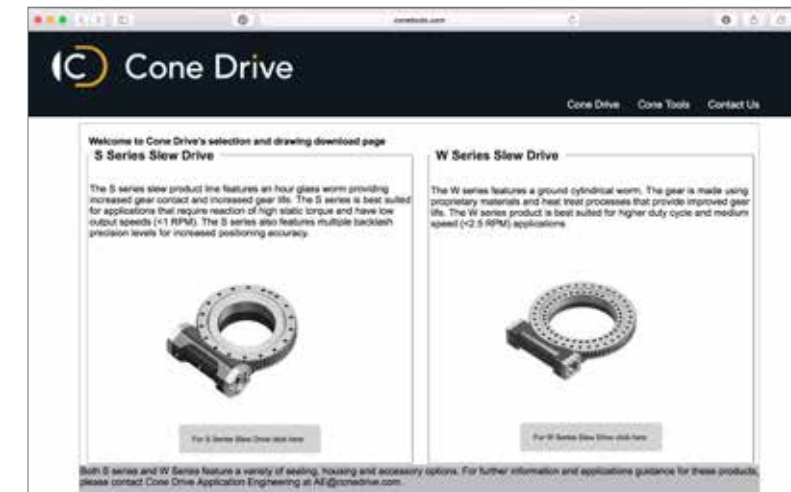

2

Select S or W Series Slewing Drive

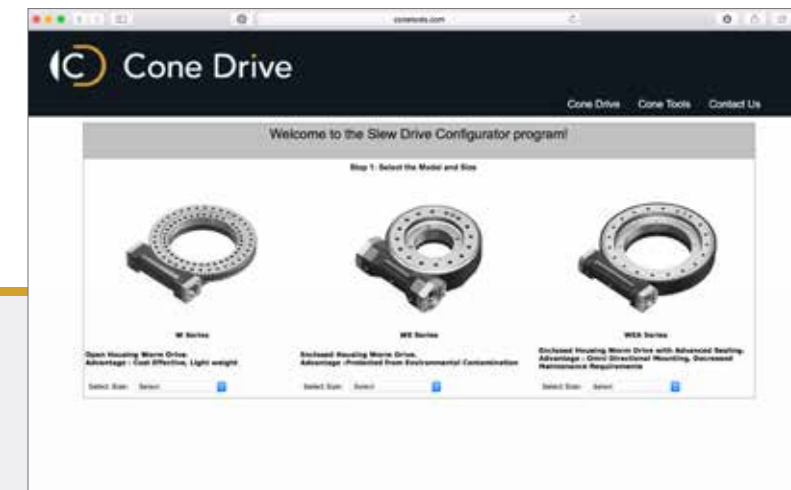

3

Select the Model and Size

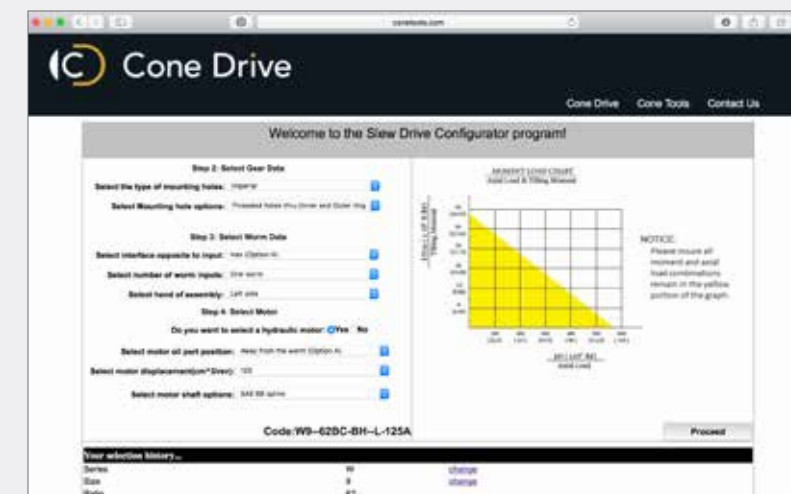

4

Select Gear Data and Proceed to Your Drive

MODEL CODE					BEARING			WORM SHAFT			HYDRAULIC MOTOR				
1	2	3	4	5	6	7	8	9	10	11	12	13	14	15	16
SE	14	A	-	85	B	T	-	B	H	-	2	R	-	160	A
↓	↓	↓		↓	↓	↓		↓	↓		↓	↓		↓	↓
<b>W</b> Open housing slewing drive	<b>7-25</b> Diameter of raceway in inches	<b>A</b> Revision level		<b>85</b> Reduction ratio	<b>-</b> Type of threaded holes: Metric	<b>-</b> Blind threaded holes, inner and outer ring		<b>-</b> Omitted with hydraulic motor	<b>-</b> Shaft opposite to motor: solid		<b>-</b> Single worm drive	<b>R</b> Hydraulic motor input position right		<b>160</b> Hydraulic motor's displacement, cc/rev.	<b>A</b> Away (oil port)
<b>WE</b> Enclosed housing slewing drive					<b>B</b> Type of threaded holes: Imperial	<b>C</b> Threaded thru holes, inner and outer ring		<b>B</b> SAE 6B spline	<b>H</b> Shaft opposite to motor: with hex		<b>2</b> Dual worm drive	<b>L</b> Hydraulic motor Input position left			<b>I</b> Inside (oil port)
<b>WEA</b> Enclosed housing slewing drive with advanced sealing						<b>T</b> Thru hole inner ring, blind threaded holes outer ring		<b>12</b> 12 mm keyed shaft	<b>E</b> Shaft opposite to motor: with encoder						<b>U</b> Up (oil port)
<b>S</b> Open housing slewing drive								<b>14</b> 14 mm keyed shaft							<b>D</b> Down (oil port)
<b>SE</b> Enclosed housing slewing drive								<b>16</b> 16 mm keyed shaft							
<b>SEA</b> Enclosed housing slewing drive with advanced sealing								<b>20</b> 20 mm keyed shaft							
								<b>25</b> 25 mm keyed shaft							
								<b>1'</b> 1' keyed shaft							

**COLUMN 15**

Size (in)	Recommended Motor Displacement (CM <sup>3</sup> /Rev)				
7	50	80	-	-	-
9	100	130	160	-	-
12	100	130	160	200	-
14	130	160	200	250	-
17	130	160	200	250	-
19	130	160	200	250	-
21	160	200	250	315	400
25	160	200	250	315	400

COLUMN 1-5

COLUMN 6-8

COLUMN 9-11

COLUMN 12-14

COLUMN 16

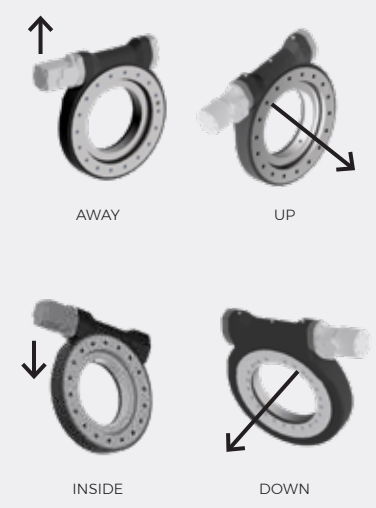
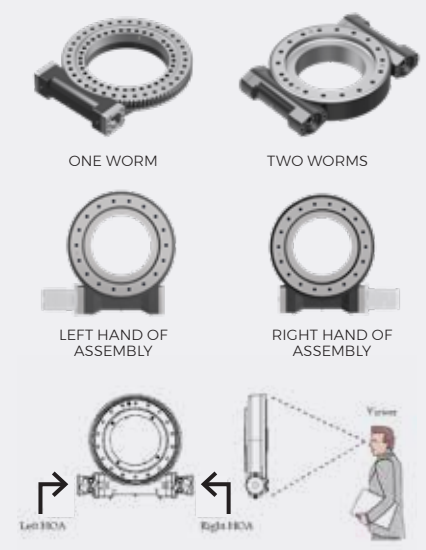
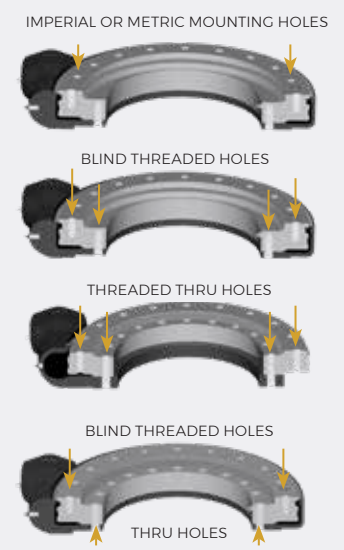

**W**

Lightweight open-gearing slewing drive solution equipped for high duty cycle, medium-speed (<2.5 RPM) applications.

- ▶ Ground cylindrical worm from proprietary materials and heat-treating processes for ultimate gear life
- ▶ 7 distinct sizes, up to 25" bearing diameter
- ▶ Standard sealing and grease fill
- ▶ Ideal for weight and cost-sensitive applications



**W EQUIVALENT MOMENT LOADING CHARTS**

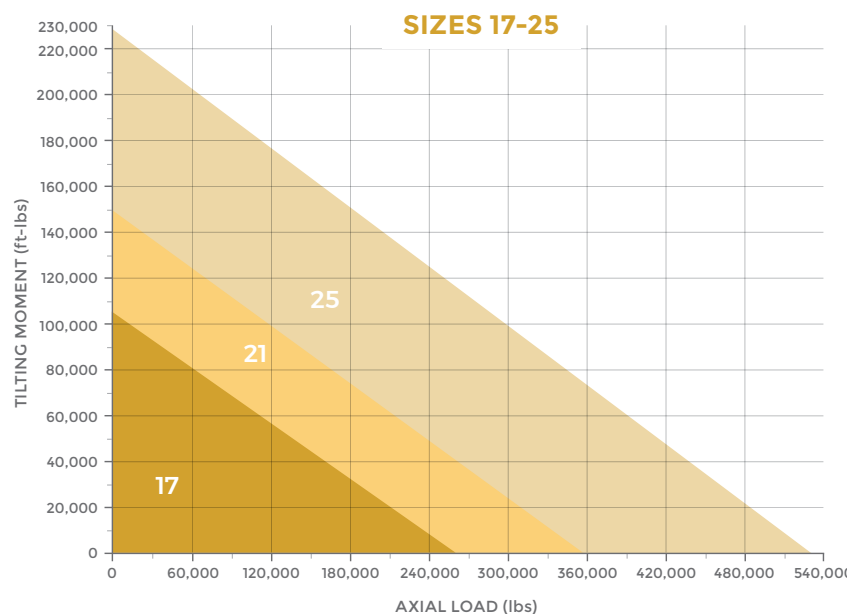
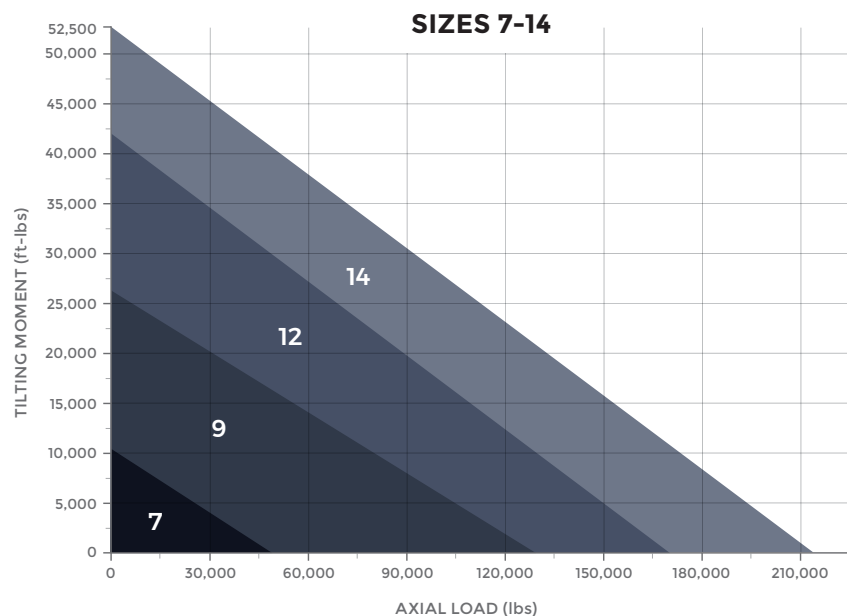

**SAE 6B SPLINE OPTION**

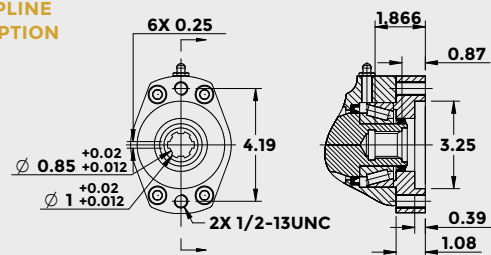

**KEYED SHAFT OPTION**

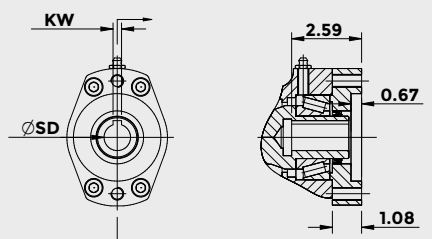

**SIDE VIEW**

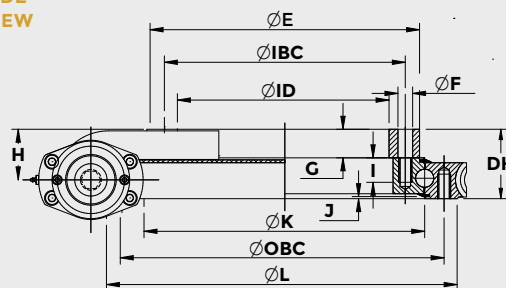

**TOP VIEW**

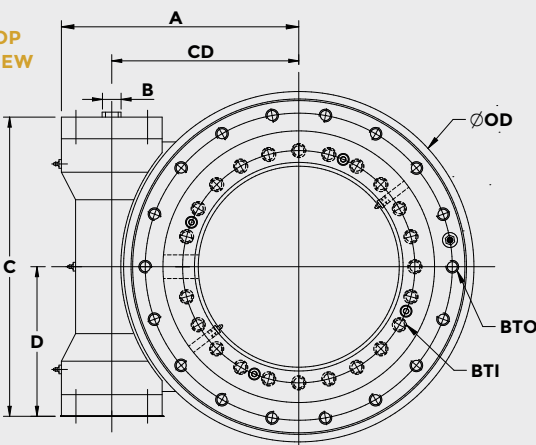

**INPUT TABLE**

ALL SIZES	ØSD (mm)	ØSD (in)	KW (mm)	KW (in)
	12	0.47	4	0.16
14	0.55	5	0.20	
16	0.63	5	0.20	
20	0.79	6	0.24	
25	0.98	8	0.31	
25.4	1.00	6.35	0.25	

**W SERIES RATINGS**

Size	Output Torque (kNm/ft-lbf)	Tilting Moment (kNm/ft-lbf)	Holding Torque (kNm/ft-lb)	Static Axial Rating (kN/lbf)	Static Radial Rating (kN/lbf)	Dynamic Axial Rating (kN/lbf)	Dynamic Radial Rating (kN/lbf)	Gear Ratio	Backlash (< degree)	Weight (kg/lbs)
7	3.5	14.2	20.0	220.0	90.0	63.0	48.0	47	0.15	29
	2,583	10,500	14,800	49,500	20,200	14,200	10,800			64
9	8.0	35.6	38.7	578.0	215.0	136.0	115.0	62	0.15	40
	5,904	26,300	29,000	129,900	48,300	30,600	25,900			88
12	9.5	57.0	43.0	760.0	280.0	190.0	148.0	79	0.15	52
14	10.8	71.2	48.0	960.0	360.0	230.0	200.0	86	0.13	62
	7,970	52,600	35,000	215,800	80,900	51,700	44,900			137
17	13.0	142.4	72.3	1166.0	435.0	280.0	231.0	104	0.1	82
	9,564	105,000	53,400	262,000	97,800	62,900	51,900			181
21	28.7	203.0	105.8	1598.0	640.0	385.0	335.0	90	0.1	139
	21,180	150,000	78,100	359,000	144,000	87,000	75,000			306
25	34.2	310.0	158.3	2360.0	945.0	590.0	470.0	104	0.1	176
	25,240	229,000	117,000	531,000	212,000	133,000	106,000			388

**W SERIES DIMENSIONS**

Size	7 (mm)	7 (in)	9 (mm)	9 (in)	12 (mm)	12 (in)	14 (mm)	14 (in)	17 (mm)	17 (in)	21 (mm)	21 (in)	25 (mm)	25 (in)
CD	142.5	5.61	180.0	7.09	222.5	8.76	237.5	9.35	285.0	11.22	350.0	13.78	399.0	15.71
ØOD	250.0	9.84	325.0	12.80	410.0	16.14	445.0	17.52	535.0	21.06	652.0	25.67	750.0	29.53
ØID	105.0	4.13	145.0	5.71	229.0	9.02	255.3	10.05	312.4	12.30	425.0	16.73	525.0	20.67
ØIBC	135.0	5.31	175.0	6.89	259.0	10.20	295.0	11.61	365.1	14.37	466.7	18.37	565.0	22.24
ØOBC	205.0	8.07	270.0	10.63	358.0	14.09	390.0	15.35	479.4	18.87	584.2	23.00	675.0	26.57
DH	80.0	3.15	80.0	3.15	80.0	3.15	85.0	3.35	87.5	3.44	110.0	4.33	110.0	4.33
BTO	10-M12	10-1/2-13	16-M16	16-5/8-11	18-M16	18-5/8-11	18-M16	18-5/8-11	20-M16	20-5/8-11	36-M20	36-3/4-10	24-M20	24-3/4-10
BTI	11-M12	11-1/2-13	15-M16	15-5/8-11	19-M16	19-5/8-11	23-M16	23-5/8-11	20-M16	20-5/8-11	35-M20	35-3/4-10	24-M20	24-3/4-10
A	206.5	8.13	244.0	9.61	286.5	11.28	301.5	11.87	349.0	13.74	415.0	16.34	464.0	18.27
B	21.0	0.83	21.0	0.83	21.0	0.83	21.0	0.83	21.0	0.83	21.0	0.83	21.0	0.83
C	295.0	11.61	330.0	12.99	370.0	14.57	380.0	14.96	405.0	15.94	482.5	19.00	512.5	20.18
D	147.5	5.81	165.0	6.50	185.0	7.28	190.0	7.48	202.5	7.97	245.0	9.65	260.0	10.24
ØE	175.0	6.89	220.0	8.66	310.0	12.20	330.0	12.99	426.0	16.77	526.0	20.71	621.0	24.45
ØF	14.0	0.55	18.0	0.71	18.0	0.71	18.0	0.71	18.0	0.71	22.0	0.87	22.0	0.87
G	22.0	0.87	30.0	1.18	30.0	1.18	35.0	1.38	30.0	1.18	40.0	1.57	40.0	1.57
H	51.0	2.01	57.0	2.24	57.0	2.24	62.0	2.44	57.0	2.24	70.0	2.76	70.0	2.76
I	22.0	0.87	30.0	1.18	30.0	1.18	30.0	1.18	30.0	1.18	40.0	1.57	40.0	1.57
J	14.8	0.58	2.5	0.10	2.5	0.10	2.5	0.10	7.0	0.28	6.5	0.26	6.5	0.26
ØK	175.0	6.89	222.5	8.76	310.0	12.20	342.0	13.46	421.0	16.57	526.0	20.71	621.0	24.45
ØL	230.0	9.06	302.0	11.89	390.0	15.35	422.0	16.61	-	-	-	-	-	-
ØSD	See 'Input Table'													
KW	See 'Input Table'													

**WE**

Robust enclosed-gearing slewing drive solution equipped for high duty cycle, medium-speed (<2.5 RPM) applications.

- ▶ Ground cylindrical worm from proprietary materials and heat-treating processes for ultimate gear life
- ▶ 6 distinct sizes, up to 25" bearing diameter
- ▶ Standard sealing and grease fill
- ▶ Ideal for dust and debris-prone environments



**WE EQUIVALENT MOMENT LOADING CHARTS**

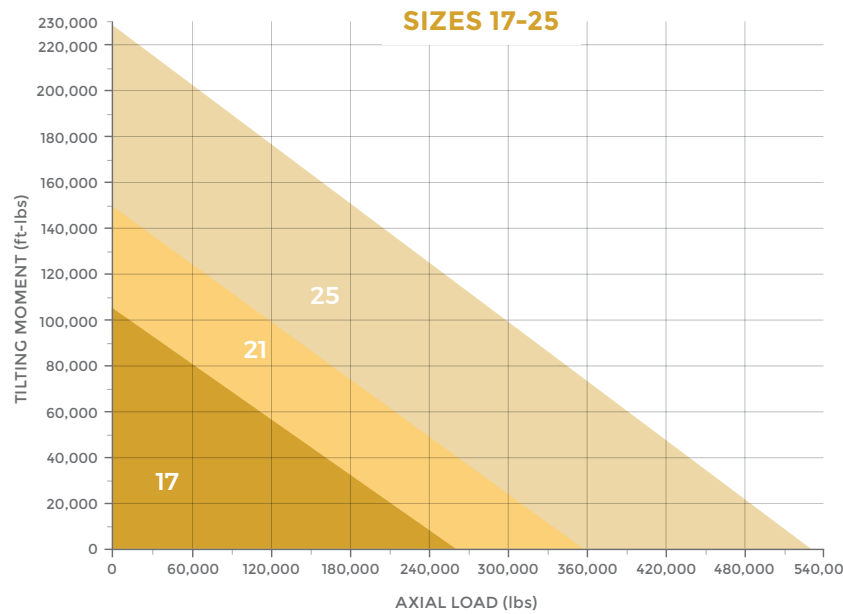
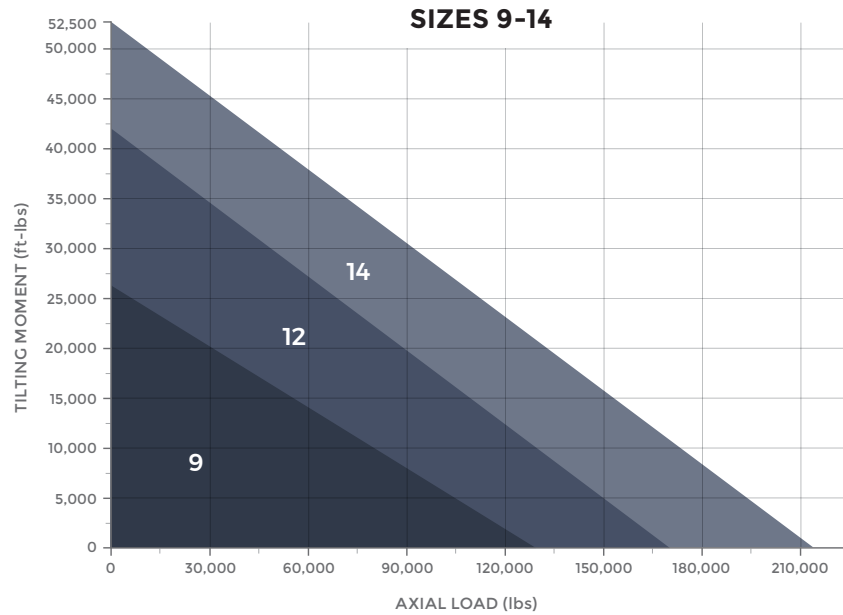

**SAE 6B SPLINE OPTION**

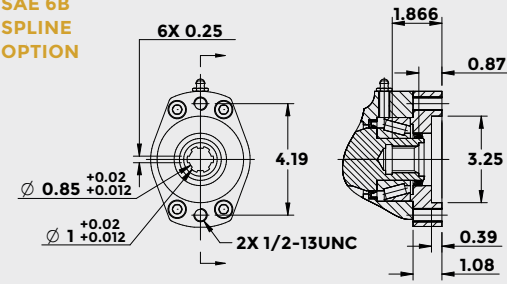

**KEYED SHAFT OPTION**

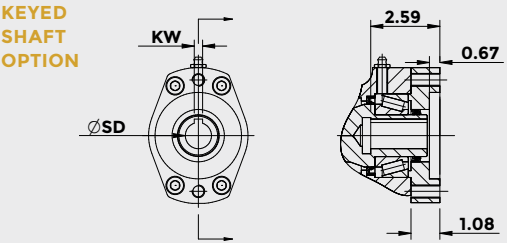

**SIDE VIEW**

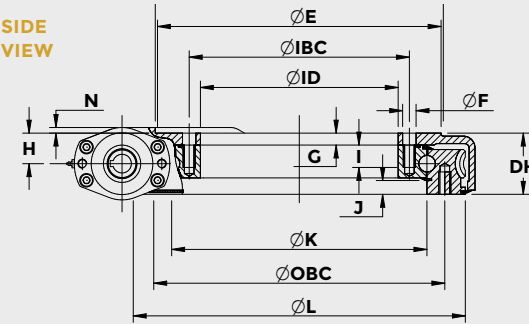

**TOP VIEW**

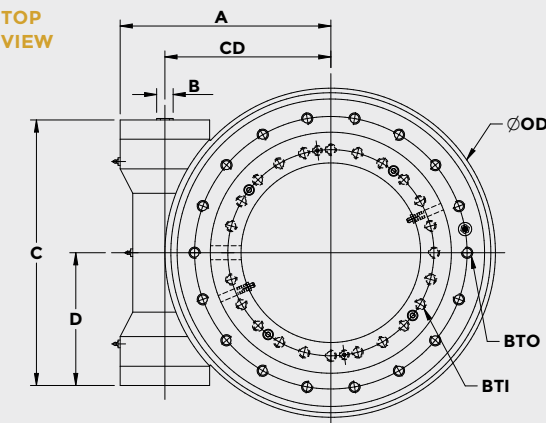

**INPUT TABLE**

ALL SIZES	ØSD (mm)	ØSD (in)	KW (mm)	KW (in)
	12	0.47	4	0.16
	14	0.55	5	0.20
	16	0.63	5	0.20
	20	0.79	6	0.24
25	0.98	8	0.31	
25.4	1.00	6.35	0.25	

**WE SERIES RATINGS**

Size	Output Torque (kNm/ft-lbf)	Tilting Moment (kNm/ft-lbf)	Holding Torque (kNm/ft-lb)	Static Axial Rating (kN/lbf)	Static Radial Rating (kN/lbf)	Dynamic Axial Rating (kN/lbf)	Dynamic Radial Rating (kN/lbf)	Gear Ratio	Backlash (< degree)	Weight (kg/lbs)
9	8.0	35.6	38.7	578.0	215.0	136.0	115.0	62	0.15	49
	5,904	26,300	29,000	129,900	48,300	30,600	25,900			
12	9.5	57.0	43.0	760.0	280.0	190.0	148.0	79	0.15	61
	7,011	42,100	32,000	171,100	62,900	42,700	33,300			
14	10.8	71.2	48.0	960.0	360.0	230.0	200.0	86	0.13	68
	7,970	52,600	35,000	215,800	80,900	51,700	44,900			
17	13.0	142.4	72.3	1166.0	435.0	280.0	231.0	104	0.1	90
	9,564	105,000	53,400	262,000	97,800	62,900	51,900			
21	28.7	203.0	105.8	1598.0	640.0	385.0	335.0	90	0.1	169
	21,180	150,000	78,100	359,000	144,000	87,000	75,000			
25	34.2	310.0	158.3	2360.0	945.0	590.0	470.0	104	0.1	199
	25,240	229,000	117,000	531,000	212,000	133,000	106,000			

**WE SERIES DIMENSIONS**

Size	9 (mm)	9 (in)	12 (mm)	12 (in)	14 (mm)	14 (in)	17 (mm)	17 (in)	21 (mm)	21 (in)	25 (mm)	25 (in)
CD	180.0	7.09	222.5	8.76	237.5	9.35	285.0	11.22	350.0	13.78	399.0	15.71
ØOD	351.0	13.82	436.0	17.17	471.0	18.54	561.0	22.09	678.0	26.69	776.0	30.55
ØID	145.0	5.71	229.0	9.02	265.0	10.43	332.0	13.07	425.0	16.73	525.0	20.67
ØIBC	175.0	6.89	259.0	10.20	295.0	11.61	365.1	14.37	466.7	18.37	565.0	22.24
ØOBC	270.0	10.63	358.0	14.09	390.0	15.35	479.4	18.87	584.2	23.00	675.0	26.57
DH	82.0	3.23	82.0	3.23	82.0	3.23	82.0	3.23	130.0	5.12	130.0	5.12
BTO	16-M16	16-5/8-11	18-M16	18-5/8-11	18-M16	18-5/8-11	20-M16	20-5/8-11	36-M20	36-3/4-10	36-M20	36-3/4-10
BTI	15-M16	15-5/8-11	19-M16	19-5/8-11	23-M16	23-5/8-11	20-M16	20-5/8-11	35-M20	35-3/4-10	35-M20	35-3/4-10
A	244.0	9.61	286.5	11.28	301.5	11.87	349.0	13.74	415.0	16.34	464.0	18.27
B	21.0	0.83	21.0	0.83	21.0	0.83	21.0	0.83	21.0	0.83	21.0	0.83
C	330.0	12.99	370.0	14.57	380.0	14.96	405.0	15.94	482.5	19.00	512.5	20.18
D	165.0	6.50	185.0	7.28	190.0	7.48	202.5	7.97	245.0	9.65	260.0	10.24
ØE	255.0	10.04	340.0	13.39	380.0	14.96	460.0	18.11	550.0	21.65	650.0	25.59
ØF	18.0	0.71	18.0	0.71	18.0	0.71	18.0	0.71	22.0	0.87	22.0	0.87
G	16.0	0.63	16.0	0.63	16.0	0.63	16.0	0.63	30.0	1.18	30.0	1.18
H	41.0	1.61	41.0	1.61	41.0	1.61	41.0	1.61	65.0	2.56	65.0	2.56
I	30.0	1.18	30.0	1.18	30.0	1.18	32.0	1.26	40.0	1.57	40.0	1.57
J	18.0	0.71	18.0	0.71	18.0	0.71	15.0	0.59	36.0	1.42	36.0	1.42
ØK	222.5	8.76	310.0	12.20	342.0	13.46	430.0	16.93	540.0	21.26	630.0	24.80
ØL	325.0	12.80	410.0	16.14	445.0	17.52	535.0	21.06	628.0	24.72	725.0	28.54
M	266	10.47	346.0	13.62	386.0	15.20	466.0	18.35	-	-	-	-
N	7.5	0.30	7.5	0.30	7.5	0.30	7.5	0.30	-	-	-	-
ØSD	See 'Input Table'											
KW	See 'Input Table'											

**WEA**

Robust enclosed-gearing slewing drive solution equipped for high duty cycle, medium-speed (<2.5 RPM) applications.

- ▶ Ground cylindrical worm from proprietary materials and heat-treating processes for ultimate gear life
- ▶ 8 distinct sizes, up to 25" bearing diameter
- ▶ Advanced sealing and grease fill
- ▶ Ideal for wet, corrosive, heavy dust and debris-prone environments



**WEA EQUIVALENT MOMENT LOADING CHARTS**

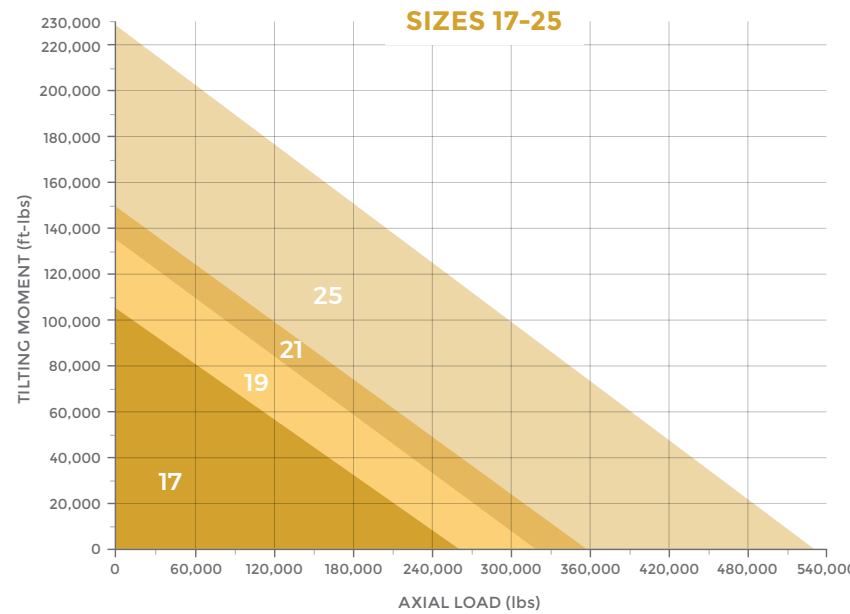
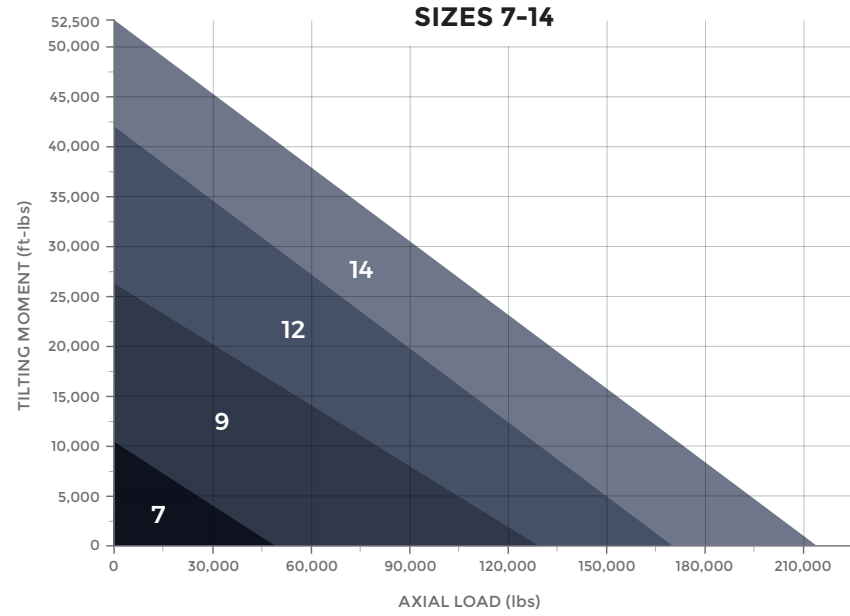

**SAE 6B SPLINE OPTION**

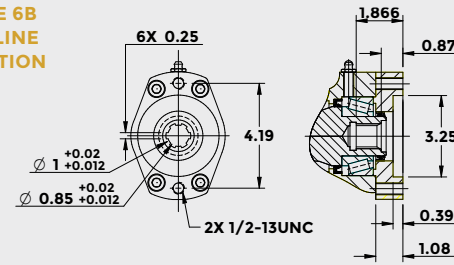

**KEYED SHAFT OPTION**

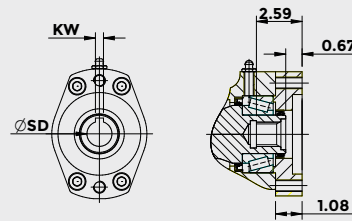

**SIDE VIEW**

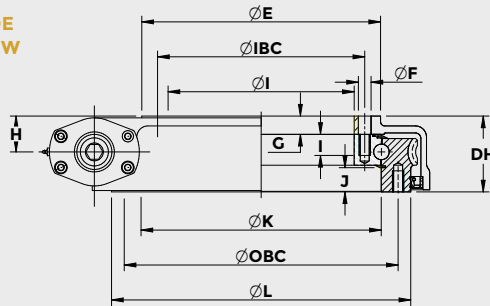

**TOP VIEW**

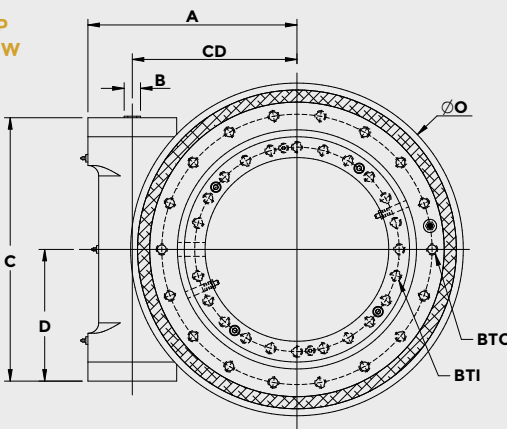

**INPUT TABLE**

	ØSD (mm)	ØSD (in)	KW (mm)	KW (in)
ALL SIZES	12	0.47	4	0.16
	14	0.55	5	0.20
	16	0.63	5	0.20
	20	0.79	6	0.24
	25	0.98	8	0.31
	25.4	1.00	6.35	0.25

**WEA SERIES RATINGS**

Size	Output Torque (kNm/ft-lbf)	Tilting Moment (kNm/ft-lbf)	Holding Torque (kNm/ft-lb)	Static Axial Rating (kN/lbf)	Static Radial Rating (kN/lbf)	Dynamic Axial Rating (kN/lbf)	Dynamic Radial Rating (kN/lbf)	Gear Ratio	Backlash (< degree)	Weight (kg/lbs)
7	3.5	14.2	20.0	220.0	90.0	63.0	48.0	47	0.15	35
	2,583	10,500	14,800	49,500	20,200	14,200	10,800			77
9	8.0	35.6	38.7	578.0	215.0	136.0	115.0	62	0.15	53
	5,904	26,300	29,000	129,900	48,300	30,600	25,900			117
12	9.5	57.0	43.0	760.0	280.0	190.0	148.0	79	0.15	67
	7,011	42,100	32,000	171,100	62,900	42,700	33,300			147
14	10.8	71.2	48.0	960.0	360.0	230.0	200.0	86	0.13	75
	7,970	52,600	35,000	215,800	80,900	51,700	44,900			165
17	13.0	142.4	72.3	1166.0	435.0	280.0	231.0	104	0.10	96
	9,564	105,000	53,400	262,000	97,800	62,900	51,900			212
19	18.5	196.0	80.1	1800.0	675.0	290.0	250.0	94	0.10	118
	13,653	144,600	59,100	404,600	151,700	65,200	56,200			260
21	28.7	203.0	105.8	1598.0	640.0	385.0	335.0	90	0.10	172
	21,180	150,000	78,100	359,000	144,000	87,000	75,000			379
25	34.2	310.0	158.3	2360.0	945.0	590.0	470.0	104	0.10	202
	25,240	229,000	117,000	531,000	212,000	133,000	106,000			445

**WEA SERIES DIMENSIONS**

Size	7 (mm)	7 (in)	9 (mm)	9 (in)	12 (mm)	12 (in)	14 (mm)	14 (in)	17 (mm)	17 (in)	19 (mm)	19 (in)	21 (mm)	21 (in)	25 (mm)	25 (in)
CD	142.5	5.61	180.0	7.09	222.5	8.76	237.5	9.35	285.0	11.22	312.5	12.30	350.0	13.78	399.0	15.71
ØO	276.0	10.87	360.0	14.17	445.0	17.52	480.0	18.90	570.0	22.44	625.0	24.61	693.0	27.28	793.0	31.22
ØI	105.0	4.13	145.0	5.71	229.0	9.02	265.0	10.43	332.0	13.07	380.0	14.96	425.0	16.73	525.0	20.67
ØIBC	135.0	5.31	175.0	6.89	259.0	10.20	295.0	11.61	365.1	14.37	420.0	16.54	466.7	18.37	565.0	22.24
ØOBC	205.0	8.07	270.0	10.63	358.0	14.09	390.0	15.35	479.4	18.87	520.0	20.47	584.2	23.00	675.0	26.57
DH	85.0	3.35	108.0	4.25	108.0	4.25	108.0	4.25	108.0	4.25	108.0	4.25	130.0	5.12	130.0	5.12
BTO	10 X M12	10 X 1/2-13	16 X M16	16 X 5/8-11	18 X M16	18 X 5/8-11	18 X M16	18 X 5/8-11	20 X M16	20 X 5/8-11	32 X M16	32 X 5/8-11	36 X M20	36 X 3/4-10	36 X M20	36 X 3/4-10
BTI	11 X M12	11 X 1/2-13	15 X M16	15 X 5/8-11	19 X M16	19 X 5/8-11	23 X M16	23 X 5/8-11	20 X M16	20 X 5/8-11	31 X M16	31 X 5/8-11	35 X M20	35 X 3/4-10	35 X M20	35 X 3/4-10
A	206.5	8.13	244.0	9.61	286.5	11.28	301.5	11.87	349.0	13.74	377.5	14.86	415.0	16.34	464.0	18.27
B	21.0	0.83	21.0	0.83	21.0	0.83	21.0	0.83	21.0	0.83	21.0	0.83	21.0	0.83	21.0	0.83
C	295.0	11.61	330.0	12.99	370.0	14.57	380.0	14.96	405.0	15.94	435.0	17.13	482.5	19.00	512.5	20.18
D	147.5	5.81	165.0	6.50	185.0	7.28	190.0	7.48	202.5	7.97	217.5	8.56	245.0	9.65	260.0	10.24
ØE	195.0	7.68	220.0	8.66	300.0	11.81	340.0	13.39	406.0	15.98	490.0	19.29	550.0	21.65	650.0	25.59
ØF	14.0	0.55	18.0	0.71	18.0	0.71	18.0	0.71	18.0	0.71	18.0	0.71	22.0	0.87	22.0	0.87
G	16.0	0.63	32.0	1.26	32.0	1.26	26.0	1.02	30.0	1.18	25.0	0.98	30.0	1.18	30.0	1.18
H	48.5	1.91	57.0	2.24	57.0	2.24	51.0	2.01	55.0	2.17	53.0	2.09	65.0	2.56	65.0	2.56
I	25.0	0.98	30.0	1.18	30.0	1.18	30.0	1.18	32.0	1.26	32.0	1.26	40.0	1.57	40.0	1.57
J	25.0	0.98	28.0	1.10	28.0	1.10	34.0	1.34	27.0	1.06	26.0	1.02	36.0	1.42	36.0	1.42
ØK	175.0	6.89	222.5	8.76	310.0	12.20	342.0	13.46	430.0	16.93	480.0	18.90	540.0	21.26	630.0	24.80
ØL	231.0	9.09	301.0	11.85	391.0	15.39	426.0	16.77	511.0	20.12	570.0	22.44	629.0	24.76	726.0	28.58
ØSD	See 'Input Table'															
KW	See 'Input Table'															

**S**

Lightweight open-gearing slewing drive solution equipped for low duty cycle, low-speed (<1 RPM) applications.

- ▶ Hour-glass worm for competitive gear contact and life, and static load capacity
- ▶ 3 distinct size offerings, up to 14" bearing diameter
- ▶ Standard sealing and grease fill
- ▶ Ideal for weight and cost-sensitive applications

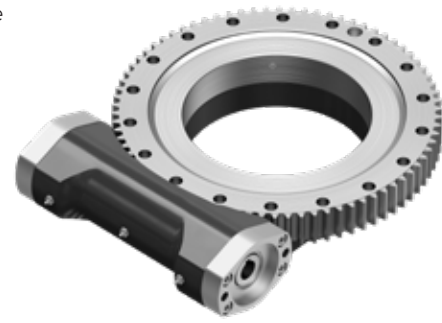

**S EQUIVALENT MOMENT LOADING CHARTS**

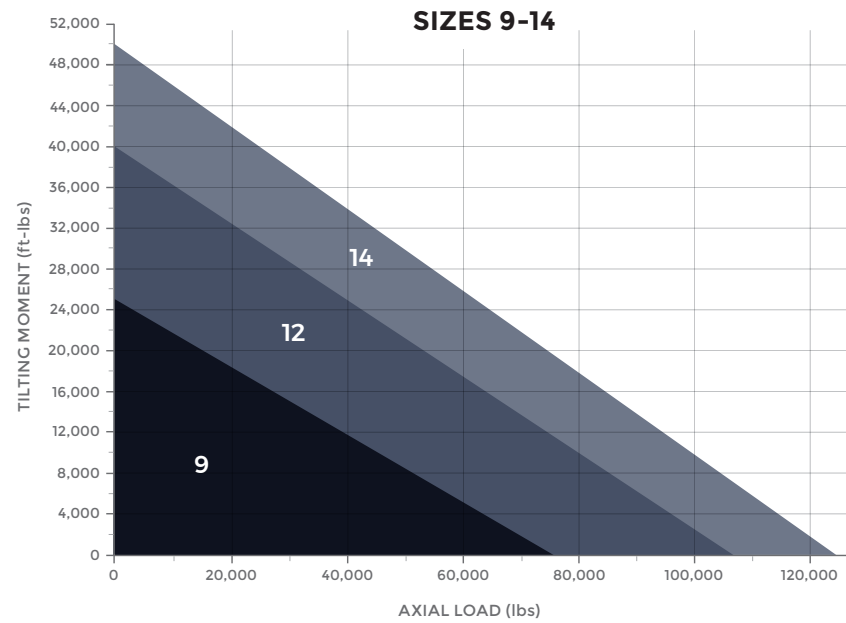

**SAE 6B SPLINE OPTION**

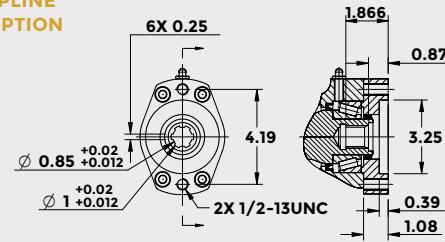

**KEYED SHAFT OPTION**

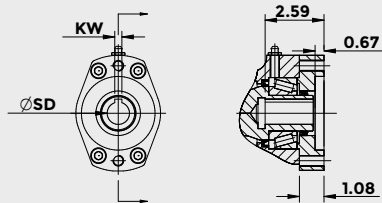

**SIDE VIEW**

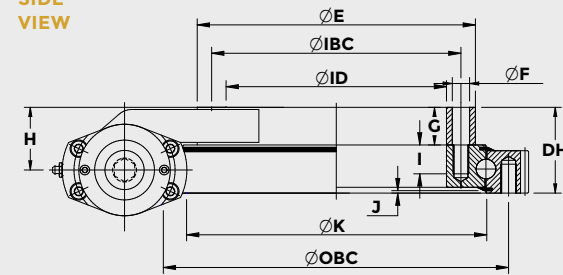

**TOP VIEW**

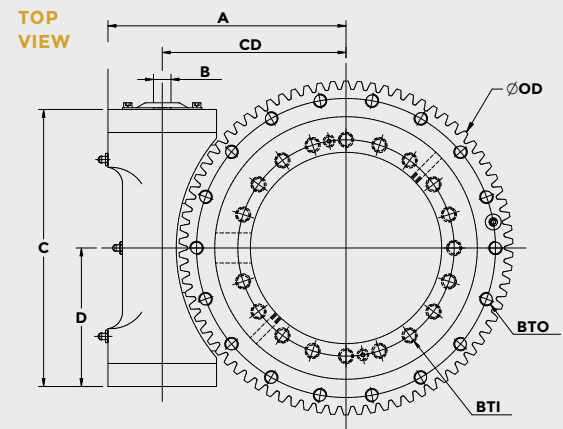

**INPUT TABLE**

ALL SIZES	ØSD (mm)	ØSD (in)	KW (mm)	KW (in)
	12	0.47	4	0.16
	14	0.55	5	0.20
	16	0.63	5	0.20
	20	0.79	6	0.24
	25.4	1.00	6.35	0.25

**S SERIES RATINGS**

Size	Output Torque (kNm/ft-lbf)	Tilting Moment (kNm/ft-lbf)	Holding Torque (kNm/ft-lb)	Static Axial Rating (kN/lbf)	Static Radial Rating (kN/lbf)	Dynamic Axial Rating (kN/lbf)	Dynamic Radial Rating (kN/lbf)	Gear Ratio	Backlash (< degree)	Weight (kg/lbs)
9	6.5	33.9	38.7	338.0	135.0	81.0	71.0	61	0.17	37
	4,794	25,000	29,000	76,000	30,000	18,000	16,000			82
12	7.5	54.3	43.0	475.0	190.0	114.0	100.0	78	0.17	41
	5,532	40,000	32,000	107,000	43,000	26,000	23,000			90
14	8.0	67.8	48.0	555.0	222.0	133.0	117.0	85	0.17	47
	5,900	50,000	35,000	125,000	50,000	30,000	26,000			104

**S SERIES DIMENSIONS**

Size	9 (mm)	9 (in)	12 (mm)	12 (in)	14 (mm)	14 (in)
CD	174.5	6.87	220.0	8.66	237.6	9.35
ØOD	314.0	12.36	400.0	15.75	434.8	17.12
ØID	145.0	5.71	229.0	9.02	265.0	10.43
ØIBC	175.0	6.89	259.0	10.20	295.0	11.61
ØOBC	270.0	10.63	358.0	14.09	390.0	15.35
DH	89.4	3.52	89.1	3.51	89.1	3.51
BTO	16-M16	16-5/8-11	18-M16	18-5/8-11	18-M16	18-5/8-11
BTI	15-M16	15-5/8-11	19-M16	19-5/8-11	23-M16	23-5/8-11
A	239.0	9.41	285.0	11.22	303.0	11.93
B	21.0	0.83	21.0	0.83	21.0	0.83
C	322.0	12.68	332.0	13.07	338.0	13.31
D	161.0	6.34	166.0	6.54	169.0	6.65
ØE	204.0	8.03	289.0	11.38	325.0	12.80
ØF	18.0	0.71	18.0	0.71	18.0	0.71
G	39.4	1.55	39.1	1.54	39.1	1.54
H	55.4	2.18	65.1	2.56	65.1	2.56
I	30.0	1.18	30.0	1.18	32.0	1.26
J	2.5	0.10	2.5	0.10	3.5	0.14
ØK	222.5	8.76	314.3	12.37	342.5	13.48
KW	See 'Input Table'					
ØSD	See 'Input Table'					



**SE**

Robust enclosed-gearing slewing drive solution equipped for low duty cycle, low-speed (<1 RPM) applications.

- ▶ Hour-glass worm for competitive gear contact and life, and static load capacity
- ▶ Multiple precision levels: variable backlash for customizable positioning accuracy
- ▶ 13 distinct size offerings, up to 25" bearing diameter
- ▶ Standard sealing and grease fill
- ▶ Ideal for dust & debris-prone environments

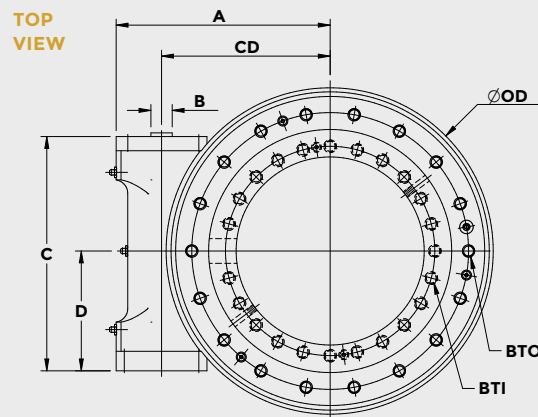
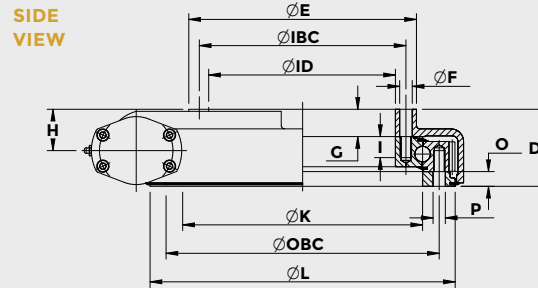
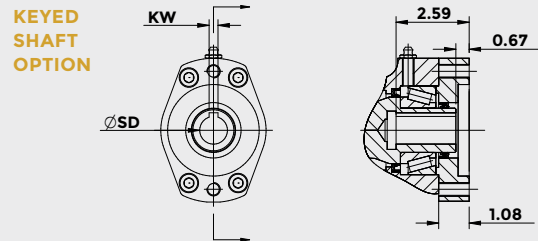
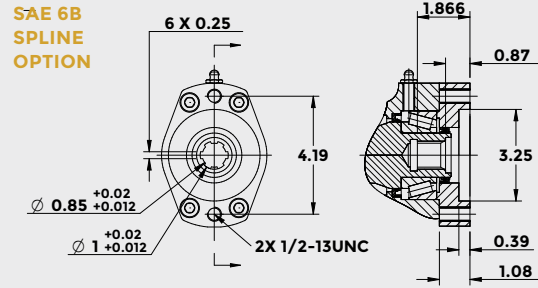

INPUT TABLE				
Size	ØSD (mm)	ØSD (in)	KW (mm)	KW (in)
3-7	12	0.47	4	0.16
3-7	14	0.55	5	0.20
3-7	16	0.63	5	0.20
9-25	12	0.47	4	0.16
9-25	14	0.55	5	0.20
9-25	16	0.63	5	0.20
9-25	20	0.79	6	0.24
9-25	25	0.98	8	0.31
9-25	25.4	1.00	6.35	0.25

**SE SERIES RATINGS**

Size	Output Torque (kNm/ft-lbf)	Tilting Moment (kNm/ft-lbf)	Holding Torque (kNm/ft-lb)	Static Axial Rating (kN/lbf)	Static Radial Rating (kN/lbf)	Dynamic Axial Rating (kN/lbf)	Dynamic Radial Rating (kN/lbf)	Gear Ratio	Backlash (< degree)	Weight (kg/lbs)
3	0.4	1.1	2.0	0.030	0.017	0.010	0.008	62	0.2	12
3	295	811	1,475	6,744	3,732	2,158	1,888	62	0.2	26
5	0.6	2.8	5.0	0.045	0.022	0.014	0.011	62	0.2	16
5	443	2,066	3,690	10,116	4,946	3,237	2,495	62	0.2	35
7	1.5	13.5	10.4	0.133	0.053	0.032	0.028	73	0.2	21
7	1,107	9,957	7,671	29,900	11,915	7,194	6,295	73	0.2	46
9	6.5	33.9	38.7	338.0	135.0	81.0	71.0	61	0.17	49
9	4,794	25,000	29,000	76,000	30,000	18,000	16,000	61	0.17	108
12	7.5	54.3	43.0	475.0	190.0	114.0	100.0	78	0.17	61
12	5,532	40,000	32,000	107,000	43,000	26,000	23,000	78	0.17	134
14	8.0	67.8	48.0	555.0	222.0	133.0	117.0	85	0.17	64
14	5,900	50,000	35,000	125,000	50,000	30,000	26,000	85	0.17	141
17	10.0	135.6	72.3	970.0	390.0	235.0	205.0	102	0.15	105
17	7,400	100,000	53,000	218,000	88,000	53,000	46,000	102	0.15	231
21	15.0	203.0	105.8	1598.0	640.0	385.0	335.0	125	0.15	149
21	11,000	150,000	78,000	359,000	144,000	87,000	75,000	125	0.15	328
25	18.0	271.0	158.3	2360.0	945.0	590.0	470.0	150	0.15	204
25	13,300	200,000	117,000	531,000	212,000	133,000	106,000	150	0.15	450

**SE SERIES DIMENSIONS**

Size	3 (mm)	3 (in)	5 (mm)	5 (in)	7 (mm)	7 (in)	9 (mm)	9 (in)	12 (mm)	12 (in)	14 (mm)	14 (in)	17 (mm)	17 (in)	21 (mm)	21 (in)	25 (mm)	25 (in)
CD	80.0	3.15	94.0	3.70	132.7	5.22	174.2	6.86	220.0	8.66	237.6	9.35	282.6	11.12	339.1	13.35	401.8	15.82
ØOD	152.0	5.98	179.0	7.05	258.0	10.16	340.0	13.39	427.0	16.81	460.0	18.11	552.6	21.76	668.0	26.30	792.0	31.18
ØID	-	-	40.0	1.57	98.0	3.86	145.0	5.71	229.0	9.02	265.0	10.43	324.0	12.76	431.8	17.00	512.0	20.16
ØIBC	100.0	3.94	100.0	3.94	120.6	4.75	175.0	6.89	259.0	10.20	295.0	11.61	365.1	14.37	466.7	18.37	565.0	22.24
ØOBC	100.0	3.94	128.0	5.04	203.2	8.00	270.0	10.63	358.0	14.09	390.0	15.35	479.4	18.87	584.2	23.00	675.0	26.57
DH	97.5	3.84	102.0	4.02	80.8	3.18	108.0	4.25	110.4	4.35	110.0	4.33	126.0	4.96	136.5	5.37	130.0	5.12
BTO	6-M10	6-3/8-16	6-M10	6-3/8-16	8-M12	8-1/2-13	16-M16	16-5/8-11	18-M16	18-5/8-11	18-M16	18-5/8-11	20-M16	20-5/8-11	36-M20	36-3/4-10	36-M20	36-3/4-10
BTI	6-M10	6-3/8-16	6-M10	6-3/8-16	10-M12	10-1/2-13	15-M16	15-5/8-11	19-M16	19-5/8-11	23-M16	23-5/8-11	20-M16	20-5/8-11	35-M20	35-3/4-10	35-M20	35-3/4-10
A	114.0	4.49	131.5	5.18	166.7	6.56	238.0	9.37	285.0	11.22	303.0	11.93	348.0	13.70	403.0	15.87	467.0	18.39
B	-	-	-	-	15.6	0.61	21.0	0.83	21.0	0.83	21.0	0.83	21.0	0.83	21.0	0.83	21.0	0.83
C	160.8	6.33	173.0	6.81	188.8	7.43	314.0	12.36	324.0	12.76	330.0	12.99	378.0	14.88	462.0	18.19	462.0	18.19
D	81.8	3.22	86.0	3.39	93.0	3.66	153.0	6.02	158.0	6.22	161.0	6.34	185.0	7.28	227.0	8.94	227.0	8.94
ØE	126.0	4.96	126.0	4.96	145.0	5.71	204.0	8.03	289.0	11.38	325.0	12.80	406.0	15.98	533.4	21.00	628.0	24.72
ØF	11.5	0.45	11.5	0.45	14.0	0.55	18.0	0.71	18.0	0.71	18.0	0.71	18.0	0.71	22.0	0.87	22.0	0.87
G	15.0	0.59	15.0	0.59	20.0	0.79	35.0	1.38	39.4	1.55	39.0	1.54	47.0	1.85	51.0	2.01	47.0	1.85
H	60.5	2.38	58.0	2.28	42.5	1.67	56.1	2.21	58.4	2.30	59.0	2.32	66.0	2.60	76.2	3.00	76.2	3.00
I	17.0	0.67	18.0	0.71	25.0	0.98	30.0	1.18	30.0	1.18	30.0	1.18	32.0	1.26	40.0	1.57	40.0	1.57
ØK	-	-	-	-	163.0	6.42	222.5	8.76	308.5	12.15	342.5	13.48	425.0	16.73	525.5	20.69	620.0	24.41
ØL	115.0	4.53	146.0	5.75	237.5	9.35	316.0	12.44	402.0	15.83	435.5	17.15	522.0	20.55	618.0	24.33	744.0	29.29
O	-	-	-	-	174	0.69	23.0	0.91	21.0	0.83	21.0	0.83	23.0	0.91	-	-	-	-
P	-	-	-	-	14.0	0.55	17.5	0.69	18.0	0.71	17.5	0.69	17.5	0.69	-	-	-	-
KW	See '3-7' Input Table'						See '9-25' Input Table'											
ØSD	See '3-7' Input Table'						See '9-25' Input Table'											

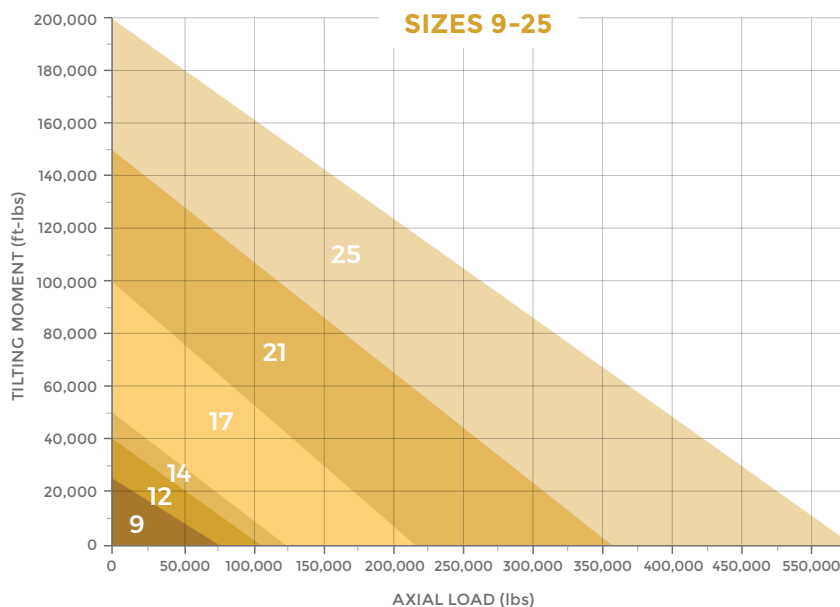
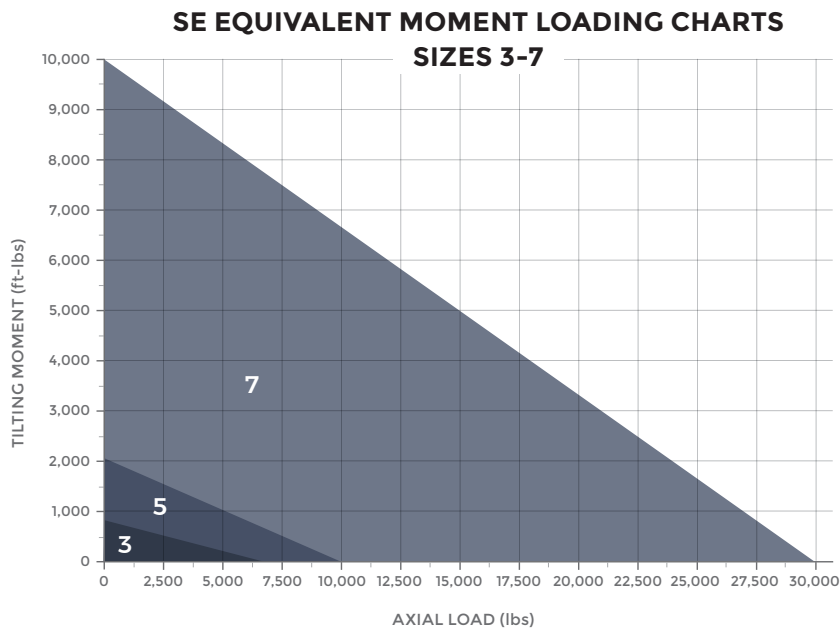

**SE-2**

Robust enclosed-gearing slewing drive solution, featuring dual-worm technology for superior dynamic and static torque capacity, equipped for low duty cycle, low-speed (<1 RPM) applications.

- ▶ Hour-glass worm for competitive gear contact and life, and static load capacity
- ▶ Multiple precision levels: variable backlash for customizable positioning accuracy
- ▶ 13 distinct size offerings, up to 25" bearing diameter
- ▶ Standard sealing and grease fill
- ▶ Ideal for dust and debris-prone environments
- ▶ Dual-worm option for additional dynamic and static torque capacity



**SAE 6B SPLINE OPTION**

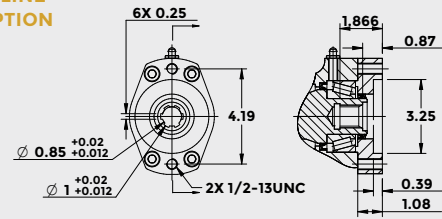

**KEYED SHAFT OPTION**

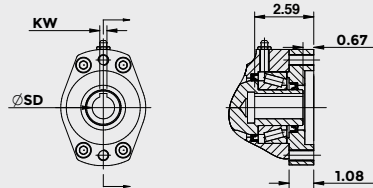

**SIDE VIEW**

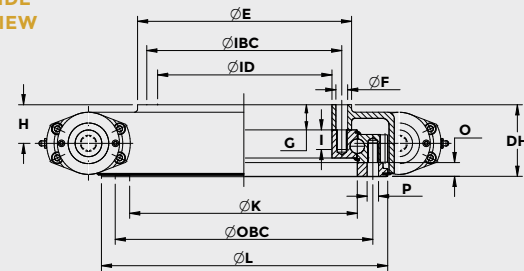

**TOP VIEW**

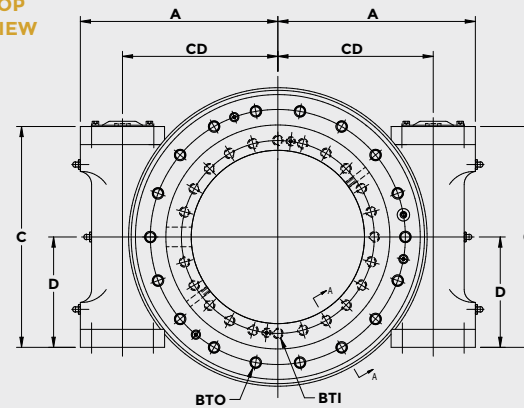

**INPUT TABLE**

ALL SIZES	ØSD (mm)	ØSD (in)	KW (mm)	KW (in)
	12	0.47	4	0.16
	14	0.55	5	0.20
	16	0.63	5	0.20
	20	0.79	6	0.24
	25	0.98	8	0.31
	25.4	1.00	6.35	0.25

**SE-2 SERIES RATINGS**

Size	Output Torque (kNm/ft-lbf)	Tilting Moment (kNm/ft-lbf)	Holding Torque (kNm/ft-lb)	Static Axial Rating (kN/lbf)	Static Radial Rating (kN/lbf)	Dynamic Axial Rating (kN/lbf)	Dynamic Radial Rating (kN/lbf)	Gear Ratio	Backlash (< degree)	Weight (kg/lbs)
14-2	12.0	67.8	81.6	555.0	222.0	133.0	117.0	85	0.17	62
	8,851	50,000	59,500	125,000	50,000	30,000	26,000			137
17-2	16.8	135.6	122.9	970.0	390.0	235.0	205.0	102	0.15	102
	12,390	100,000	90,000	218,000	88,000	53,000	46,000			225
21-2	20.6	203.0	179.9	1598.0	640.0	385.0	335.0	125	0.15	143
	15,194	150,000	132,600	359,000	144,000	87,000	75,000			315
25-2	28.0	271.0	269.1	2360.0	945.0	590.0	470.0	150	0.15	202
	20,652	200,000	198,900	531,000	212,000	133,000	106,000			445

**SE-2 SERIES DIMENSIONS**

Size	14 (mm)	14 (in)	17 (mm)	17 (in)	21 (mm)	21 (in)	25 (mm)	25 (in)
CD	237.6	9.35	282.6	11.12	339.1	13.35	401.8	15.82
ØOD	456.6	17.98	552.5	21.75	-	-	792.0	31.18
ØID	265.0	10.43	324.0	12.76	431.8	17.00	512.0	20.16
ØIBC	295.0	11.61	365.1	14.37	466.7	18.37	565.0	22.24
ØOBC	390.0	15.35	479.4	18.87	584.2	23.00	675.0	26.57
DH	110.0	4.33	126.0	4.96	120.0	4.72	130.0	5.12
BTO	18-M16	18-5/8-11	20-M16	20-5/8-11	36-M20	36-3/4-10	36-M20	36-3/4-10
BTI	23-M16	23-5/8-11	20-M16	20-5/8-11	35-M20	35-3/4-10	35-M20	35-3/4-10
A	302.0	11.89	346.5	13.64	403.0	15.87	467.0	18.39
B	21.0	0.83	21.0	0.83	21.0	0.83	21.0	0.83
C	338.0	13.31	385.0	15.16	469.0	18.46	469.0	18.46
D	169.0	6.65	193.0	7.60	234.5	9.23	234.6	9.24
ØE	325.0	12.80	406.0	15.98	533.4	21.00	628.0	24.72
ØF	18.0	0.71	18.0	0.71	22.0	0.87	22.0	0.87
G	39.0	1.54	47.0	1.85	34.2	1.35	47.0	1.85
H	59.0	2.32	66.0	2.60	64.0	2.52	76.2	3.00
I	30.0	1.18	32.0	1.26	40.0	1.57	40.0	1.57
ØK	342.5	13.48	425.0	16.73	525.5	20.69	620.0	24.41
ØL	435.5	17.15	522.0	20.55	618.0	24.33	744.0	29.29
ØO	21.0	0.83	23.0	0.91	-	-	-	-
ØP	17.5	0.69	17.5	0.69	-	-	-	-

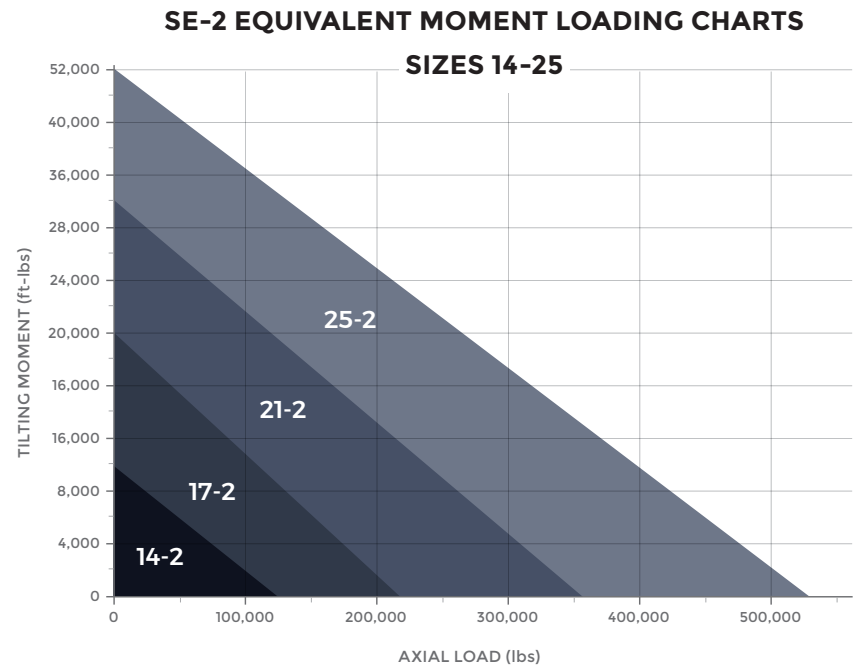

**SEA**

Robust enclosed-gearing slewing drive solution equipped for low duty cycle, low-speed (<1 RPM) applications.

- ▶ Hour-glass worm for competitive gear contact and life, and static load capacity
- ▶ Multiple precision levels: variable backlash for customizable positioning accuracy
- ▶ 6 distinct size offerings, up to 25" bearing diameter
- ▶ Advanced sealing and grease fill
- ▶ Ideal for wet, corrosive, heavy dust and debris-prone environments



**SEA EQUIVALENT MOMENT LOADING CHARTS**

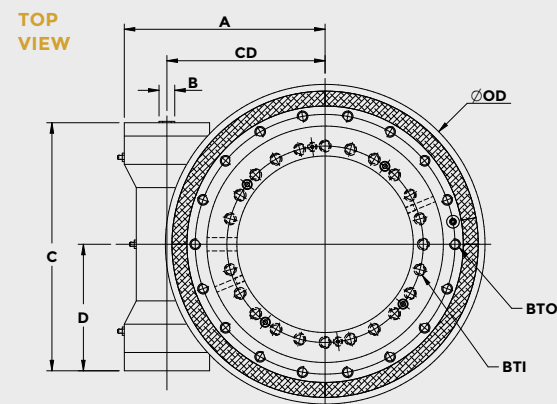
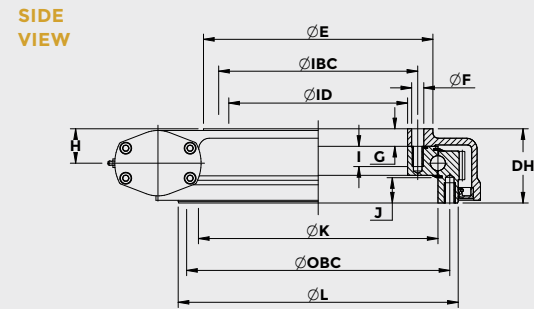
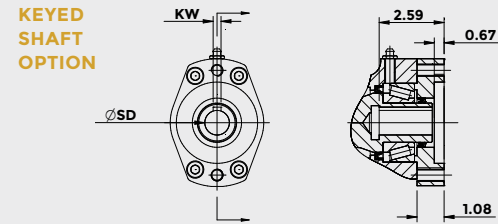
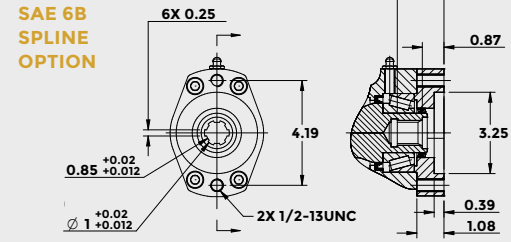
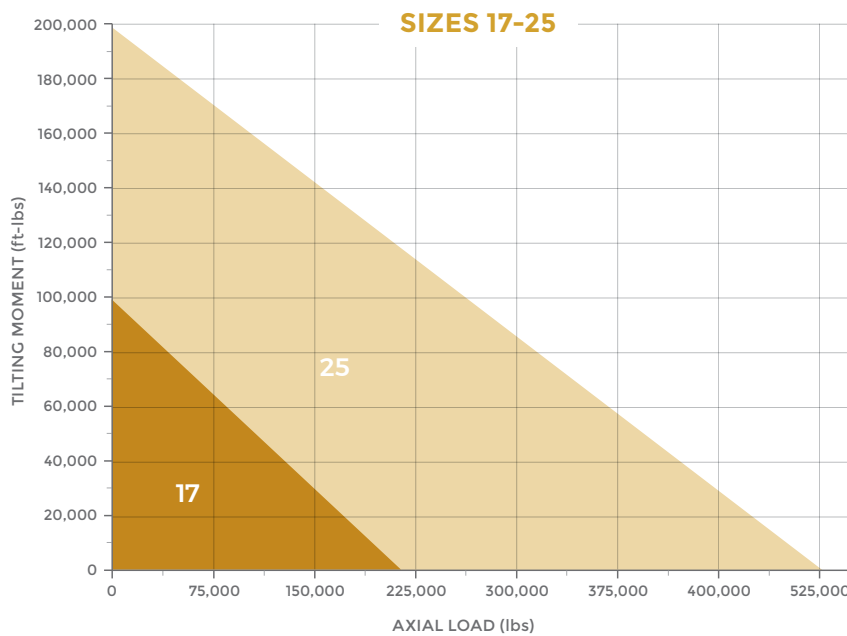
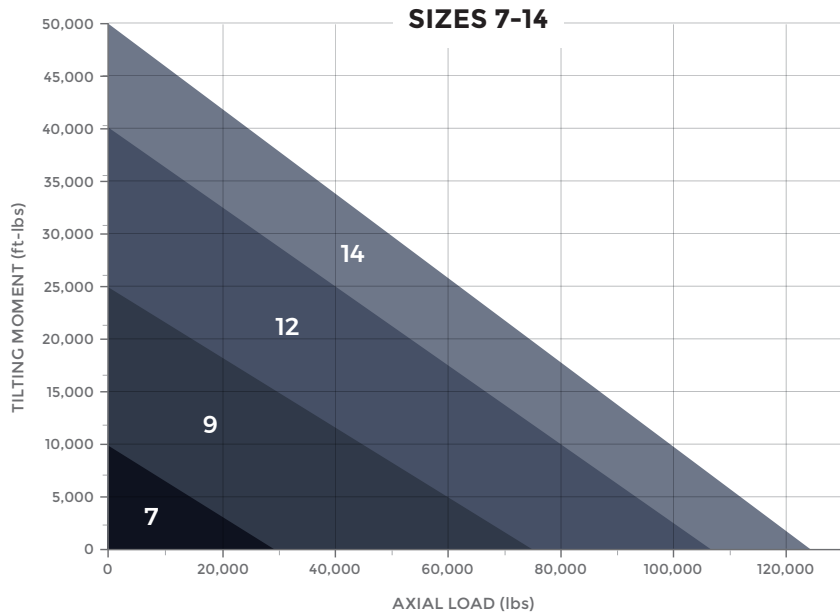

**INPUT TABLE**

ALL SIZES	ØSD (mm)	ØSD (in)	KW (mm)	KW (in)
	12	0.47	4	0.16
14	0.55	5	0.20	
16	0.63	5	0.20	
20	0.79	6	0.24	
25	0.98	8	0.31	
25.4	1.00	6.35	0.25	

**SEA SERIES RATINGS**

Series	Output Torque (kNm/ft-lbf)	Tilting Moment (kNm/ft-lbf)	Holding Torque (kNm/ft-lb)	Static Axial Rating (kN/lbf)	Static Radial Rating (kN/lbf)	Dynamic Axial Rating (kN/lbf)	Dynamic Radial Rating (kN/lbf)	Gear Ratio	Backlash (< degree)	Weight (kg/lbs)
7	1.5	13.5	10.4	133.0	53.0	32.0	28.0	73	0.2	25
	1,107	9,957	7,671	29,900	11,915	7,194	6,295			55
9	6.5	33.9	38.7	338.0	135.0	81.0	71.0	61	0.17	48
	4,794	25,000	29,000	76,000	30,000	18,000	16,000			106
12	7.5	54.3	43.0	475.0	190.0	114.0	100.0	78	0.17	63
	5,532	40,000	32,000	107,000	43,000	26,000	23,000			139
14	8.0	67.8	48.0	555.0	222.0	133.0	117.0	85	0.17	64
	5,900	50,000	35,000	125,000	50,000	30,000	26,000			141
17	10.0	135.6	72.3	970.0	390.0	235.0	205.0	102	0.15	88
	74,000	100,000	53,000	218,000	88,000	53,000	46,000			194
25	18.0	271.0	158.3	2360.0	945.0	590.0	470.0	150	0.15	158
	13,300	200,000	117,000	531,000	212,000	133,000	106,000			348

**SEA SERIES DIMENSIONS**

Size	7 (mm)	7 (in)	9 (mm)	9 (in)	12 (mm)	12 (in)	14 (mm)	14 (in)	17 (mm)	17 (in)	25 (mm)	25 (in)
CD	132.7	5.22	174.2	6.86	220.0	8.66	237.5	9.35	282.6	11.12	386.8	15.23
ØOD	266.0	10.47	342.0	13.46	437.0	17.20	480.0	18.90	562.0	22.13	780.0	30.71
ØID	98.0	3.86	146.0	5.75	229.0	9.02	265.0	10.43	350.0	13.78	525.0	20.67
ØIBC	120.6	4.75	175.0	6.89	259.0	10.20	295.0	11.61	386.0	15.20	565.0	22.24
ØOBC	203.2	8.00	270.0	10.63	358.0	14.09	390.0	15.35	479.4	18.87	675.0	26.57
DH	80.8	3.18	108.0	4.25	108.0	4.25	110.0	4.33	110.0	4.33	108.0	4.25
BTO	8-M12	8-1/2-13	16-M16	16-5/8-11	18-M16	18-5/8-11	18-M16	18-5/8-11	20-M16	20-5/8-11	36-M20	36-3/4-10
BTI	10-M12	10-1/2-13	15-M16	15-5/8-11	19-M16	19-5/8-11	23-M16	23-5/8-11	20-M16	20-5/8-11	35-M20	35-3/4-10
A	170.2	6.70	238.0	9.37	284.0	11.18	301.5	11.87	347.0	13.66	451.8	17.79
B	21.0	0.83	21.0	0.83	21.0	0.83	21.0	0.83	21.0	0.83	21.0	0.83
C	211.0	8.31	314.0	12.36	342.5	13.48	372.5	14.67	387.5	15.26	477.5	18.80
D	106.0	4.17	161.0	6.34	175.0	6.89	190.0	7.48	197.5	7.78	242.5	9.55
ØE	150.0	5.91	204.0	8.03	300.0	11.81	340.0	13.39	430.0	16.93	628.0	24.72
ØF	14.0	0.55	18.0	0.71	18.0	0.71	18.0	0.71	18.0	0.71	22.0	0.87
G	22.0	0.87	30.0	1.18	30.0	1.18	26.0	1.02	31.0	1.22	28.0	1.10
H	40.0	1.57	52.0	2.05	52.5	2.07	51.0	2.01	56.0	2.20	53.0	2.09
I	25.0	0.98	30.0	1.18	30.0	1.18	30.0	1.18	32.0	1.26	40.0	1.57
J	10.0	0.39	30.5	1.20	30.5	1.20	37.0	1.46	27.0	1.06	18.5	0.73
ØK	163.0	6.42	222.5	8.76	320.0	12.60	355.0	13.98	435.0	17.13	622.0	24.49
ØL	221.0	8.70	296.0	11.65	382.0	15.04	415.0	16.34	505.0	19.88	710.0	27.95
KW	See 'Input Table'											
ØSD	See 'Input Table'											

**HSE**

Robust enclosed-gearing slewing drive solution equipped for low-speed (<1 RPM) applications.

- ▶ Hour-glass worm and bronze gear for competitive gear contact and life and dynamic load capacity
- ▶ 3 distinct sizes, up to 25" bearing diameter
- ▶ Advanced sealing and grease fill
- ▶ Ideal for wet, corrosive, heavy dust and debris-prone environments
- ▶ Dual-worm option for additional dynamic and static torque capacity
- ▶ Common to wheel drive applications



**HSE EQUIVALENT MOMENT LOADING CHARTS**

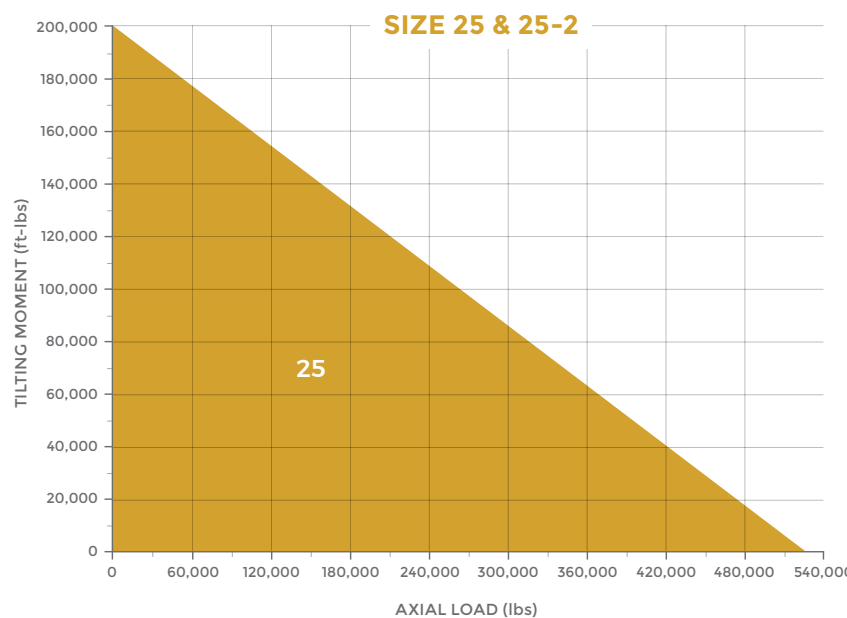
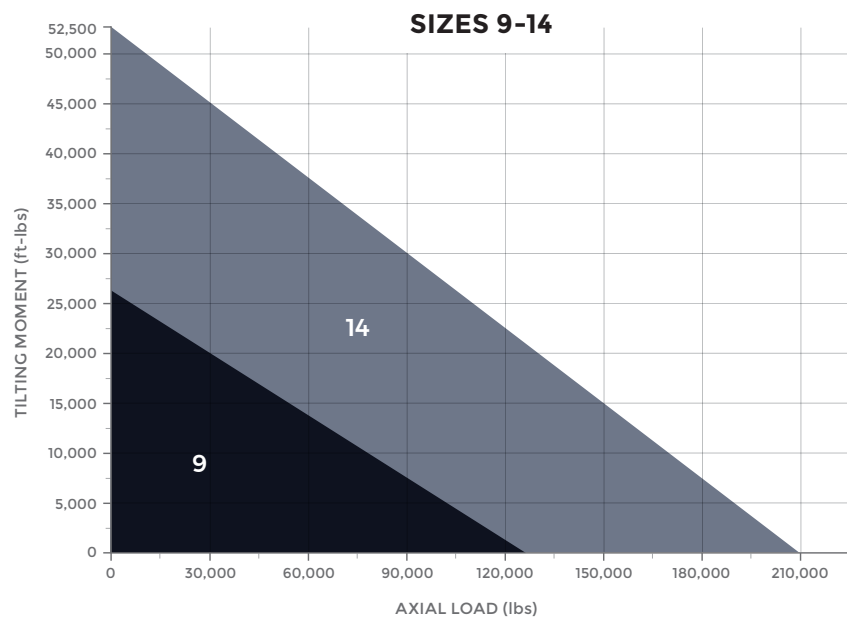

**SAE 6B SPLINE OPTION**

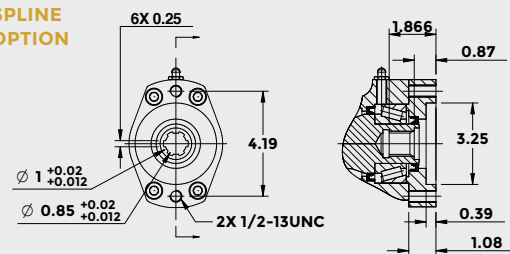

**KEYED SHAFT OPTION**

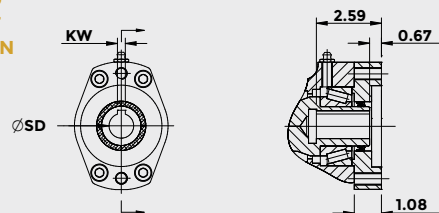

**SIDE VIEW**

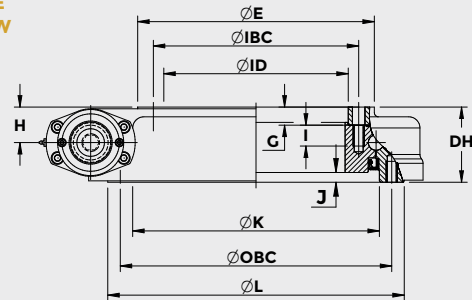

**TOP VIEW**

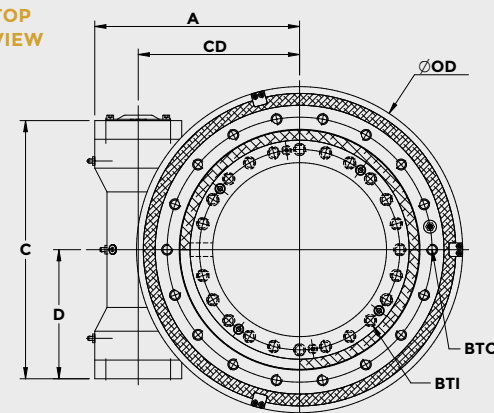

**INPUT TABLE**

ALL SIZES	$\phi SD$ (mm)	$\phi SD$ (in)	KW (mm)	KW (in)
	12	0.47	4	0.16
	14	0.55	5	0.20
	16	0.63	5	0.20
	20	0.79	6	0.24
	25	0.98	8	0.31
	25.4	1.00	6.35	0.25

**HSE SERIES RATINGS**

Size	Output Torque (kNm/ft-lbf)	Max Output Torque (kNm/ft-lbf)	Tilting Moment (kNm/ft-lb)	Static Axial Rating (kN/lbf)	Static Radial Rating (kN/lbf)	Dynamic Axial Rating (kN/lbf)	Dynamic Radial Rating (kN/lbf)	Gear Ratio	Backlash (< degree)	Weight (kg/lbs)
9	9.0	10.8	35.6	578.0	215.0	136.0	115.0	62	0.15	53
	6,642	7,970	26,300	129,900	48,300	30,600	25,900			117
14	12.0	14.4	71.2	960.0	360.0	230.0	200.0	86	0.13	80
	8,856	10,627	52,600	215,800	80,900	51,700	44,900			176
25	25.0	30.0	271.0	2360.0	945.0	590.0	470.0	94	0.15	255
	18,439	22,100	200,000	531,000	212,000	133,000	106,000			562
25-2	50.0	60.0	271.0	2360.0	945.0	590.0	470.0	94	0.15	255
	36,878	44,200	200,000	531,000	212,000	133,000	106,000			562

**HSE SERIES DIMENSIONS**

Size	9 (mm)	9 (in)	14 (mm)	14 (in)	25 (mm)	25 (in)	25-2 (mm)	25-2 (in)
CD	180.0	7.09	237.5	9.35	416.0	16.38	416.0	16.38
$\phi OD$	360.0	14.17	480.0	18.90	889.0	35.00	972.0	38.27
$\phi ID$	145.0	5.71	256.0	10.08	512.0	20.16	512.0	20.16
$\phi IBC$	175.0	6.89	295.0	11.61	560.0	22.05	560.0	22.05
$\phi OBC$	270.0	10.63	390.0	15.35	685.0	26.97	685.0	26.97
DH	108.0	4.25	108.0	4.25	148.0	5.83	148.0	5.83
BTO	16-M16	16-5/8-11	18-M16	18-5/8-11	30-M16	30-5/8-11	30-M16	30-5/8-11
BTI	15-M16	15-5/8-11	23-M16	23-5/8-11	29-18 thru	29-0.708 thru	29-18 thru	29-0.708 thru
A	244.0	9.61	301.5	11.87	486.0	19.13	486.0	19.13
B	21.0	0.83	21.0	0.83	21.0	0.83	21.0	0.83
C	330.0	12.99	380.0	14.96	511.0	20.12	511.0	20.12
D	165.0	6.50	190.0	7.48	255.5	10.06	255.5	10.06
$\phi E$	220.0	8.66	340.0	13.39	628.0	24.72	628.0	24.72
$\phi F$	18.0	0.71	18.0	0.71	-	-	-	-
G	32.0	1.26	26.0	1.02	23.0	0.91	23.0	0.91
H	57.0	2.24	51.0	2.01	76.2	3.00	76.2	3.00
I	30.0	1.18	30.0	1.18	40.0	1.57	40.0	1.57
J	18.0	0.71	22.0	0.87	30.0	1.18	30.0	1.18
$\phi K$	222.5	8.76	345.0	13.58	-	-	-	-
$\phi L$	301	11.85	426.0	16.77	722.0	28.43	722.0	28.43
KW	See 'Input Table'							
$\phi SD$	See 'Input Table'							

**R**

Compact enclosed-gearing slewing drive solution equipped to serve as a high speed (<10 rpm) drive component for slew bearings.

- ▶ Ground cylindrical worm and bronze gear for competitive gear contact life and dynamic load capacity
- ▶ 5 distinct sizes, up to 114 mm gear center distance
- ▶ Standard sealing and grease fill
- ▶ Ideal for dust and debris-prone environments
- ▶ Supplied with pinion and mounting interface for ease of installation to slew bearing system



**R EQUIVALENT MOMENT LOADING CHART  
SIZES 72-114**

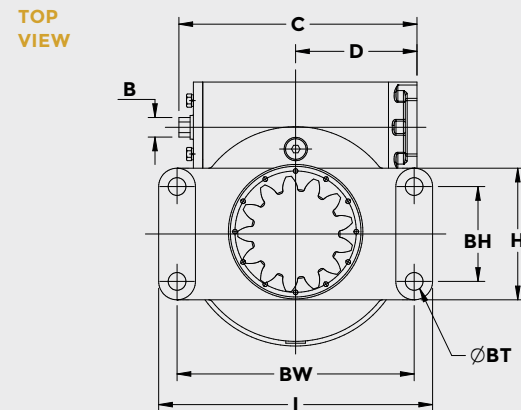
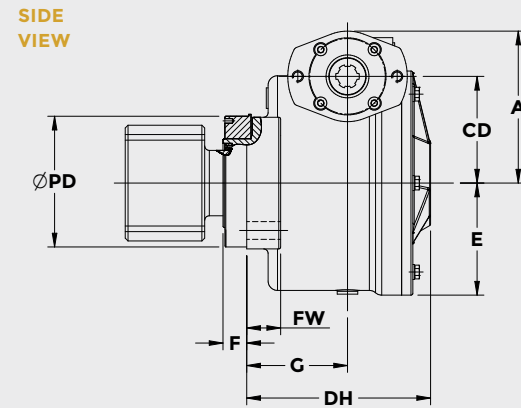
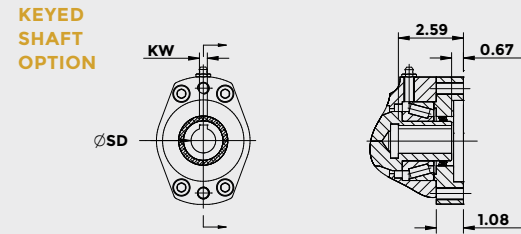
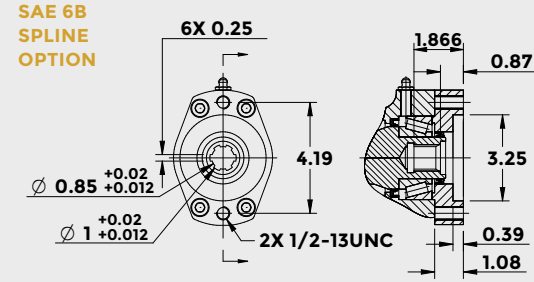
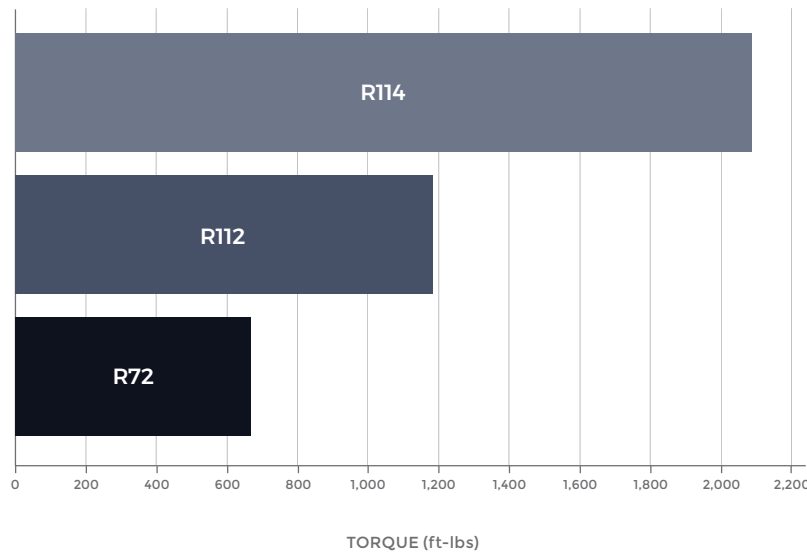

**INPUT TABLE**

ALL SIZES	ØSD (mm)	ØSD (in)	KW (mm)	KW (in)
	12	0.47	4	0.16
	14	0.55	5	0.20
	16	0.63	5	0.20
	20	0.79	6	0.24
	25	0.98	8	0.31
	25.4	1.00	6.35	0.25

**R SERIES RATINGS**

Size	Output Torque (kNm/ft-lbf)	Gear Ratio	Weight (kg/lbs)
72	0.9	30	23
	665		51
110	1.6	39	38
	1,181		84
114	2.8	44	52
	2,083		115

**R SERIES DIMENSIONS**

Size	72 (mm)	72 (in)	110 (mm)	110 (in)	114 (mm)	114 (in)
CD	72.3	2.84	110.7	4.36	114.3	4.50
ØPD	101.6	4.00	101.6	4.00	95.2	3.75
BH	65.0	2.56	82.5	3.25	101.6	4.00
BW	190.5	7.50	232.0	9.13	254.0	10.00
DH	123.4	4.86	144.5	5.69	197.0	7.75
ØBT	4 X 16	4 X 0.63	4 X 16.7	4 X 0.66	4 X 19.0	4 X 0.75
FW	25.4	1.00	22.5	0.89	36.32	1.43
A	136.3	5.36	174.7	6.88	162.8	6.41
B	21.0	0.83	21	0.83	21	0.83
C	236.0	9.29	226.0	8.90	255.0	10.04
D	120.5	4.74	115.5	4.55	130.0	5.12
E	74.1	2.92	113.0	4.45	120.0	4.72
F	26.6	1.05	37.5	1.48	25.4	1.00
G	65.4	2.57	67.5	2.66	108.0	4.25
H	95.0	3.74	112.5	4.43	141.0	5.55
I	218.5	8.60	262.0	10.31	293.4	11.55
ØSD	See 'Input Table'					
KW	See 'Input Table'					

**SLEWING RINGS**

Versatile bearing solutions featuring external, internal, and absent teeth options equipped to suit every slewing application.

- ▶ Several material options with design flexibility and customization options
- ▶ 4-point contact bearings
- ▶ 28 distinct sizes, up to 39" bearing diameter
- ▶ Standard sealing and grease fill

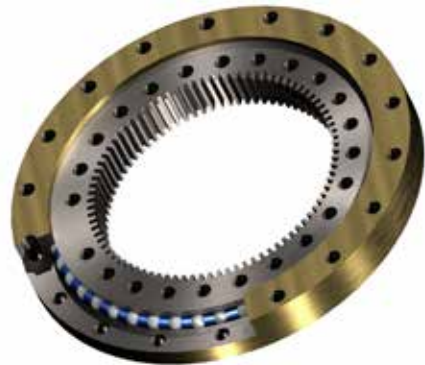
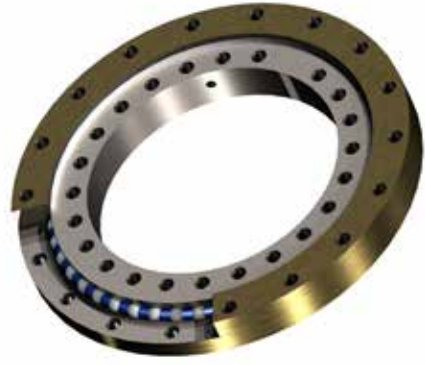

**CUSTOM & COMPETITIVE CROSS OVERS AVAILABLE**

**NO TEETH**

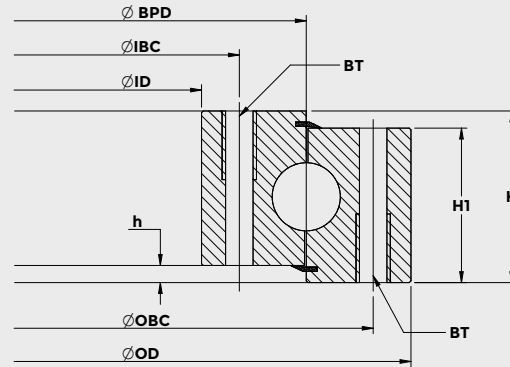

**INNER TEETH**

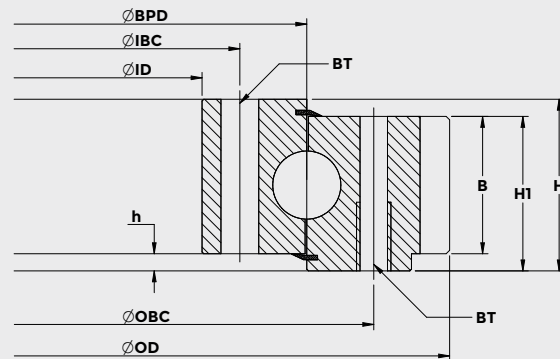

**OUTER TEETH**

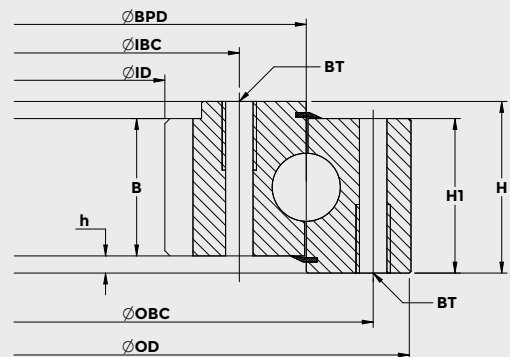

**SLEWING RING SIZE & GEAR PARAMETERS**

SI No.	Part No. (No Teeth)	Part No. (Outer Teeth)	Part No. (Inner Teeth)	BPD (in)	OD (in)	ID (in)	H (in)	OBC (in)	IBC (in)	Bolt No. (per Race)	BT	D1 (in)	H1 (in)	H (in)	B (in)	Deflection (x)	MOD (x)	Teeth No. (Z)	
1	010.20.200	011.20.200	013.20.200	7.87	11.02	4.72	2.36	9.76	5.98	12	16 mm thru - M14	7.83	1.97	1.57	-	-	3	98	
2	010.20.224	011.20.224	013.20.224	8.82	11.97	5.67		10.71	6.93			105							
3	010.20.250	011.20.250	013.20.250	9.84	12.99	6.69		11.73	7.95	18		86							
4	010.22.280	011.22.280	013.22.280	11.02	14.17	7.87		12.91	9.13			94							
5	010.25.315	011.25.315	013.25.315	12.40	16.06	8.74	2.76	14.65	10.16	20	0.39	1.97	-	-	5	85			
6	010.25.355	011.25.355	013.25.355	13.98	17.64	10.31		16.22	11.73							93			
7	010.25.400	011.25.400	13.20.400	15.75	19.41	12.09		17.99	13.50	24					86				
8	010.25.450	011.25.450	013.25.450	17.72	21.38	14.06		19.96	15.47						94				
9	010.30.500	011.30.500	013.30.500	19.69	23.70	15.67	20	22.28	17.09	18	18 mm thru - M16	19.61	2.76	2.36	-	-	5	123	
10	012.30.500	014.30.500	6									102							
11	010.25.500	011.25.500	013.25.500									5					123		
12	012.25.500	014.25.500	6									102							
13	010.30.560	011.30.560	013.30.560	22.05	26.06	18.03	3.15	24.65	19.45	20	21.97	2.76	2.36	-	-	-	5	135	
14	012.30.560	014.30.560	6														112		
15	010.25.560	011.25.560	013.25.560														5	135	
16	012.25.560	014.25.560	6														112		
17	010.30.630	011.30.630	013.30.630	24.80	28.82	20.79	24	27.40	22.20	18	24.72	0.39	0.5	-	-	-	6	126	
18	012.30.630	014.30.630	8														94		
19	010.25.630	011.25.630	013.25.630														6	126	
20	012.25.630	014.25.630	8														94		
21	010.30.710	011.30.710	013.30.710	27.95	31.97	23.94	24	30.55	25.35	20	27.87	27.91	-	-	-	-	6	139	
22	012.30.710	014.30.710	8														104		
23	010.25.710	011.25.710	013.25.710														6	139	
24	012.25.710	014.25.710	8														104		
25	010.40.800	011.40.800	013.40.800	31.50	36.30	26.69	3.94	34.57	28.43	30	22 mm thru - M20	31.42	3.54	3.15	-	-	-	8	118
26	012.40.800	014.40.800	10															94	
27	010.30.800	011.30.800	013.30.800															8	118
28	012.30.800	014.30.800	10															94	

# GLOBAL LOCATIONS

NORTH AMERICA | EUROPE | ASIA

